

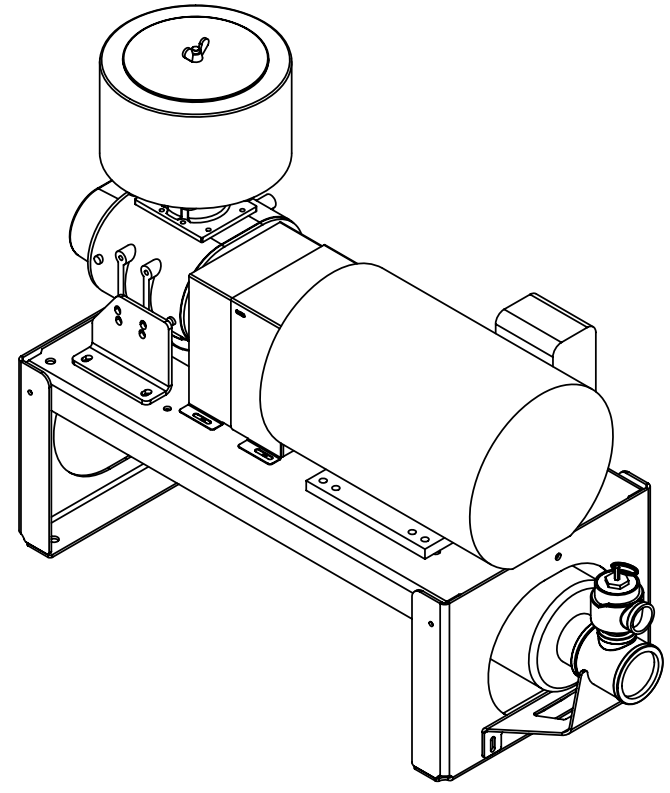

DWG. NO.  
PD406FT40FC32AH

REVISIONS				
ZONE	REV.	DESCRIPTION	DATE	APPROVED
	A			
	B			
	C			

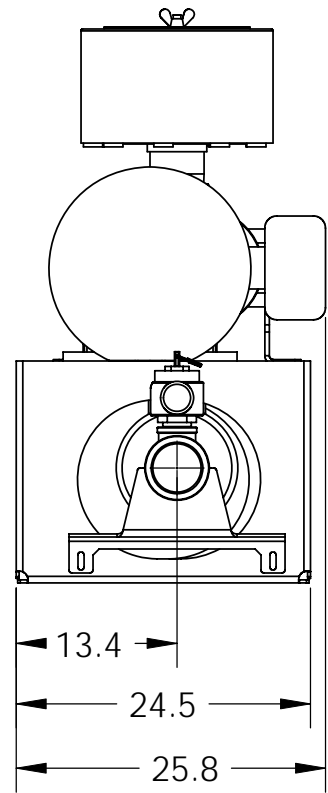
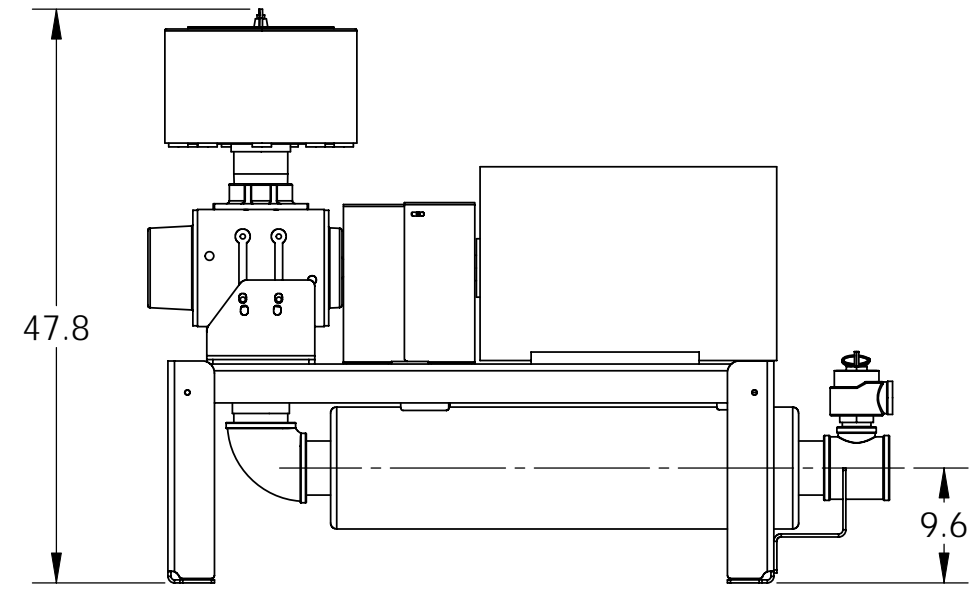
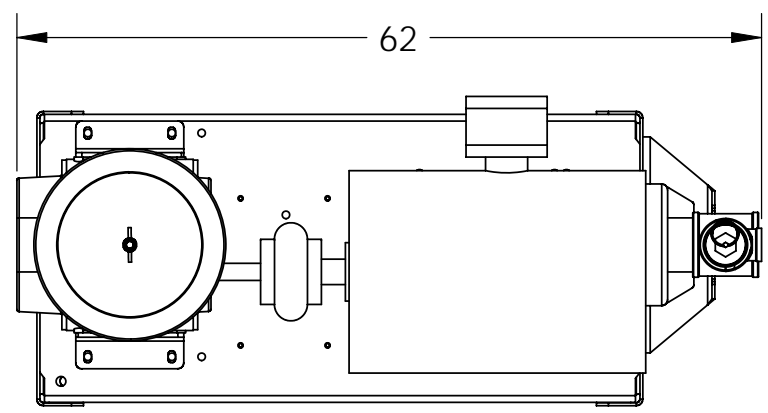

**PROPRIETARY AND CONFIDENTIAL**  
THE INFORMATION CONTAINED IN THIS DRAWING IS THE SOLE PROPERTY OF REP Inc. ANY REPRODUCTION IN PART OR AS A WHOLE WITHOUT THE WRITTEN PERMISSION OF REP Inc. IS PROHIBITED.

		UNLESS OTHERWISE SPECIFIED:		DATE	NAME	 REP Inc. 2405 Murphy Blvd. Gainesville, GA 30504 800-536-9933
		DIMENSIONS ARE IN INCHES TOLERANCES: FRACTIONAL ± ANGULAR: MACH ± BEND ± TWO PLACE DECIMAL ± THREE PLACE DECIMAL ±		DRAWN	6-25-05	
		INTERPRET GEOMETRIC TOLERANCING PER:		CHECKED		<b>TITLE:</b> PKG,ROOTSFLO MODEL 406 40HP MOTOR 4" INLET & DISCHARGE
		MATERIAL		ENG APPR.		
		FINISH --		MFG APPR.		
NEXT ASSY		USED ON		Q.A.		<b>SIZE</b> <b>B</b>
APPLICATION		WEIGHT:		COMMENTS: THICKNESS:		
						REV SHEET 1 OF 1
				SCALE: 1:16		

8 7 6 5 4 3 2 1

D  
C  
B  
A

D  
C  
B  
A

8 7 6 5 4 3 2 1