

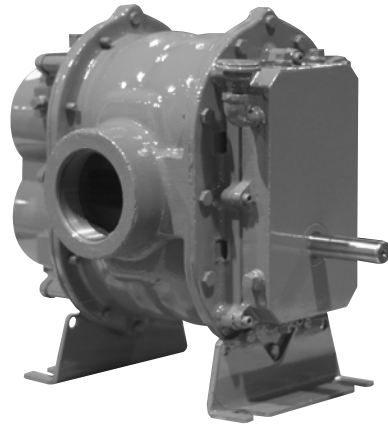

URAI-J™ DSL Frames 33J through 56J

ROOTS® Universal RAI-J™ DSL Blowers



Design and construction features

- Lower air pulsation
- Longer bearing life
- Lower vibration

ROOTS® Patented Universal RAI-J™ WHISPAIR™ Dual Splash Lubricated (DSL) blowers are heavy-duty rotary units in a compact, sturdy design, engineered for continuous service when operated within speed and vacuum/pressure ratings.

Basic blower description

The basic model features a cast iron casing with a computer-designed cast relief for noise and shock suppression. Carburized and ground alloy steel spur timing gears are secured to steel shafts with a taper mounting and locknut. The unit features cast iron involute impellers. Oversized anti-friction bearings are used, with a cylindrical roller bearing at the drive shaft to withstand V-belt pull. Detachable rugged steel mounting feet permit easy in-field adaptability to either vertical or horizontal installation requirements.

The Universal RAI-J™ DSL design incorporates dual splash lubrication to the gear AND drive ends. ROOTS® exclusive “figure-eight” gearbox design improves oil distribution to maximize bearing and gear life. Sight glasses (3/8”) are provided for accurate oil level confirmation.

Lower vibration

The reduction in the magnitude of the pressure pulsation results in smoother operation.

Longer bearing life

The pre-pressurization of the low pressure pocket through the WHISPAIR™ blower jet cavity smooths the pulsations, resulting in less shock being transmitted through the impellers to the bearings, providing longer bearing life.

Lower air pulsation

Patented WHISPAIR blowers operate with up to 40% less pressure pulsation than conventional blowers, due to the pressure equalizing effect of the WHISPAIR blower jet design.

In conventional blowers, as the impeller opens up to the outlet port, the higher pressure air in the discharge line rapidly expands into the lower pressure pocket formed by the impeller and the blower case. The resulting shock wave strikes the advancing surface of the impeller at nearsonic velocity. Four pressure pulses occur during each revolution, transmitting shock loads to the gear and bearings.

Lower noise

The pressure pulses, inherent in the rotary-lobe design, are also the major source of blower noise. The rapid backflow of air into the blower from the discharge line, four times per revolution, results in high noise levels in a conventional blower. The WHISPAIR jet design controls the backflow of air into the blower, reducing noise by approximately 5 dBA vacuum, 3 dB pressure.

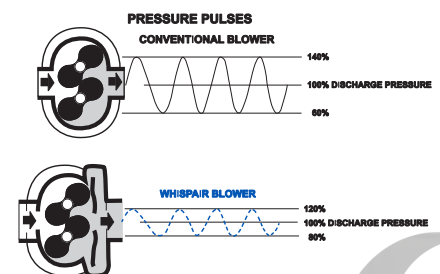
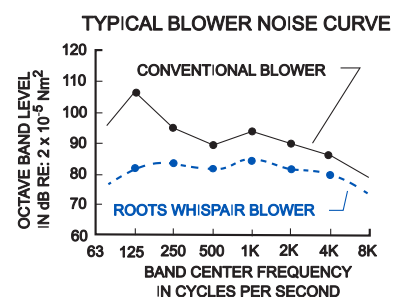
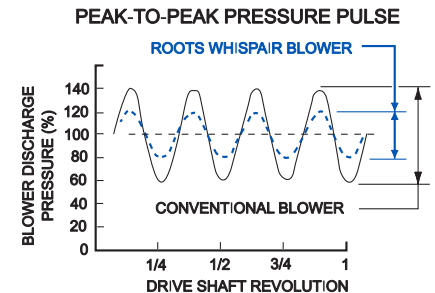

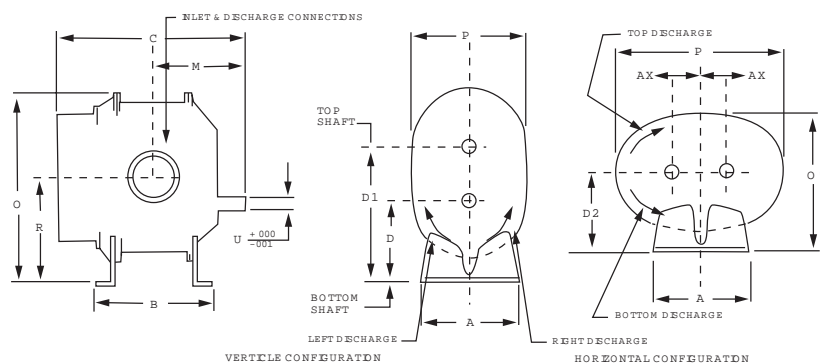

Vertical configuration
(Horizontal air flow)

Horizontal configuration
(Vertical air flow)

Outline drawing of ROOTS RAI-J DSL blower

For further information contact:

ROOTS
900 W. Mount Street,
Connersville, Indiana, 47331
USA

Tel: +1 765 827 9200

Web: www.RootsBlower.com

Dimensional table

Frame size	A	B	C	D	D1	D2	M	O	O1	P	R	U	AX	Inlet disch.	Weight
33	7.25	7.63	12.13	5.00	8.50	5.00	6.25	12.81	10.00	10.00	6.75	.750	1.75	2.0 NPT	84
36	7.25	10.00	14.63	5.00	8.50	5.00	7.56	12.81	10.50	10.50	6.75	.750	1.75	2.5 NPT	112
45	8.00	10.00	15.50	6.25	10.25	6.25	8.00	15.06	12.25	12.00	8.25	.875	2.00	2.5 NPT	119
47	8.00	11.75	17.63	6.25	10.25	6.25	9.25	15.06	12.25	12.00	8.25	.875	2.00	3.0 NPT	138
56	10.50	1.00	17.50	6.25	11.25	6.75	9.19	17.38	14.00	14.00	8.75	1.125	2.50	4.0 NPT	190

Performance table

Frame size	Speed RPM	1 PSI		6 PSI		7 PSI		10 PSI		12 PSI		13 PSI		MAX VACUUM		
		CFM	BHP	CFM	BHP	CFM	BHP	CFM	BHP	CFM	BHP	CFM	BHP	"HG	CFM	BHP
33	1160	55	0.3	31	1.9	28	2.2	-	-	-	-	-	-	10	27	1.5
	2800	156	0.9	132	4.6	129	5.4	120	7.7	116	9.2	-	-	14	113	5.2
	3600	205	1.2	181	6.1	178	7.0	170	9.9	165	11.9	-	-	15	159	7.3
36	1160	95	0.5	61	3.1	57	3.6	-	-	-	-	-	-	10	55	2.5
	2800	262	1.5	229	7.7	224	8.9	-	-	-	-	-	-	12	213	7.5
	3600	344	2.1	310	10.1	306	11.7	-	-	-	-	-	-	15	278	12.1
45	860	79	0.5	42	2.7	37	3.2	-	-	-	-	-	-	8	46	1.8
	1760	188	1.0	151	5.7	146	6.6	133	9.4	-	-	-	-	12	134	5.5
	3600	410	2.7	374	12.2	369	14.1	356	19.8	-	-	-	-	16	332	15.4
47	860	105	0.6	59	3.6	53	4.2	-	-	-	-	-	-	8	63	2.4
	1760	249	1.3	203	7.5	196	8.7	-	-	-	-	-	-	12	181	7.3
	3600	542	3.5	496	16.1	490	18.6	-	-	-	-	-	-	15	452	19.1
56	700	123	0.7	78	4.1	72	4.7	-	-	-	-	-	-	10	70	3.3
	1760	358	2.0	312	10.5	306	12.2	290	17.3	280	20.6	276	22.3	14	276	11.8
	2850	598	4.0	553	17.7	547	20.5	531	28.7	521	34.2	517.0	37.0	16	501	22.4

Notes:

1. Pressure ratings based on inlet air at standard pressure of 14.7 psia, standard temperature of 68° F, and specific gravity of 1.0.
2. Vacuum ratings based on inlet air at standard temperature of 68°F, discharge pressure of 30" Hg and specific gravity of 1.0.