

RAM™ Blowers, 404 thru 624

# Roots™ RAM™ Rotary Positive Blowers

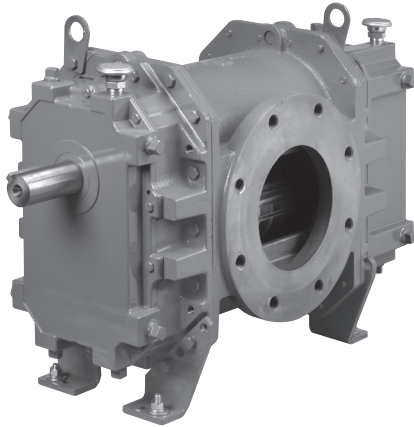

## Frames 404 thru 624

### Design and construction features

- Horizontal and vertical configurations available
- Improved volumetric efficiency and reduced operating temperatures
- Alloy steel timing gears
- Cylindrical roller bearings
- Piston ring air seals
- Lip-type, hydrodynamic oil seals
- Splash oil lubrication

**RAM™ stands for Reliability, Availability and Maintainability. Today, more than ever, Roots is committed to supplying our customers with reliable products manufactured with state-of-the-art CNC machine tools. Production and inventory are being scheduled and controlled to ensure these units will be available when you need them. Design improvements such as repositionable rugged steel mounting feet and die-cast aluminum drive end covers and gear covers help to reduce installation costs and make normal maintenance easier.**

### Basic Blower Operations

RAM™ rotary blowers are heavy-duty units designed with integral-shaft ductile iron impellers having an involute profile. The headplates and rigid, one-piece casing are grey iron, while the drive end cover and gear cover are aluminum. Carburized and ground alloy steel spur timing gears are taper mounted on the shafts, secured with a locknut. Cylindrical roller bearings are used on all units.

Piston rings reduce air leakage through the shaft openings in the headplates, and lip-type oil seals prevent lubricant from entering the air chamber. A hydrodynamic seal on the drive shaft prevents shaft seal oil leaks.

RAM rotary blowers incorporate thrust control, with splash oil lubrication at both ends of the blower.

All frame sizes are designed with detachable rugged steel mounting feet which permit in-field adaptability to either vertical or horizontal installation requirements.

The top shaft is extended for drive on side outlet blowers, and either shaft can be extended for drive on top or bottom outlet blowers.

### Warranty period

Twenty-Four (24) months from date of original unit start-up or 30 months from date of original shipment, whichever occurs first.

### Operating Principle

Two figure-eight lobe impellers mounted on parallel shafts rotate in opposite directions. As each impeller passes the blower inlet, it traps a definite volume of air and carries it around the case to the blower outlet,

where the air is discharged. With constant speed operation the displaced volume is essentially the same regardless of pressure, temperature or barometric pressure. Timing gears control the relative position of

the impellers to each other and maintain small but definite clearances. This allows operation without lubrication being required inside the air casing.

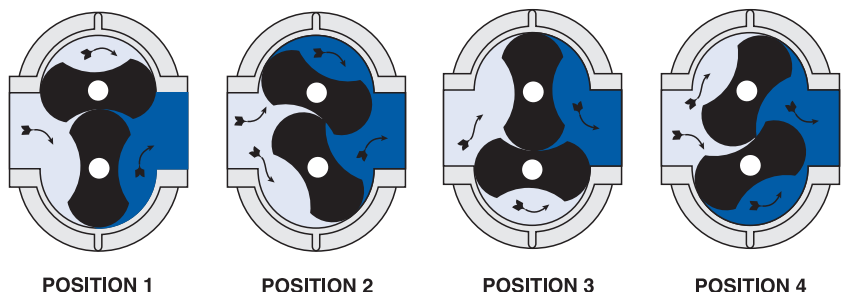

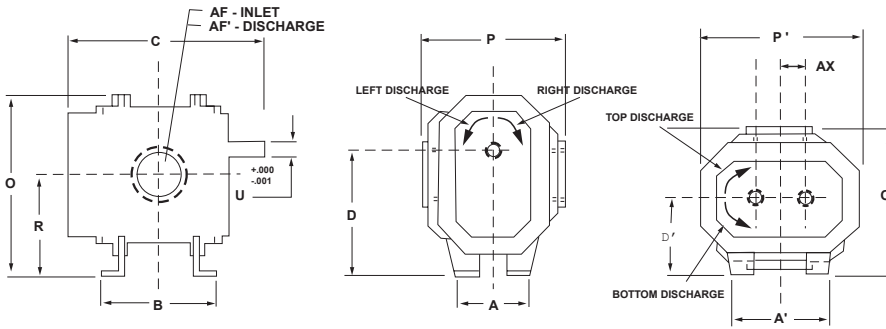

**For further information contact**

**Howden Roots**  
 900 W. Mount St.  
 Connersville  
 Indiana  
 USA  
 47331  
 Tel: +1 765 827 9200  
 Web: www.howden.com

Frame size	Speed RPM	4 PSI		6 PSI		8 PSI		10 PSI		12 PSI		15 PSI		18 PSI		MAX VACUUM		
		CFM	BHP	CFM	BHP	CFM	BHP	CFM	BHP	CFM	BHP	CFM	BHP	CFM	BHP	"HG	CFM	BHP
404	1750	148	3.6	139	5.3	130	6.9	123	8.6	116	10.3	-	-	-	-	14.0	114	5.8
	2950	280	6.8	271	9.5	262	12.3	255	15.1	248	17.9	239	22	-	-	15.0	240	10.8
	4000	396	10.4	386	14.1	378	17.8	370	21.5	364	25.2	355	30.7	347	36.2	16.0	350	15.8
406	1750	225	5.4	210	7.9	198	10.5	187	13	177	15.5	-	-	-	-	14.0	173	8.8
	2950	426	10.0	411	14.2	398	18.4	387	22.6	377	26.8	363	33.2	-	-	15.0	365	16.2
	4000	601	15.1	586	20.7	574	26.3	562	31.9	552	37.5	539	45.9	526	54.3	16.0	531	23.7
409	1750	338	8.0	315	11.8	296	15.6	279	19.4	264	23.2	-	-	-	-	14.0	259	13.2
	2950	638	14.7	615	21	596	27.3	579	33.6	564	39.9	544	49.3	-	-	15.0	546	24.2
	4000	900	21.9	878	30.3	859	38.7	842	47	827	55.4	806	68	788	80.5	16.0	796	35.2
412	1750	450	10.6	420	15.7	394	20.7	372	25.8	352	30.8	-	-	-	-	14.0	344	17.6
	2950	849	19.4	819	27.8	794	36.2	772	44.6	752	52.9	724	65.5	-	-	15.0	728	32.1
	4000	1199	28.8	1169	39.9	1144	51.1	1121	62.2	1101	73.4	1074	90.1	-	-	16.0	1060	46.6
418	1750	675	15.9	630	23.5	592	31.1	559	38.7	-	-	-	-	-	-	14.0	501	25.7
	2950	1275	28.9	1230	41.5	1192	54.1	1159	66.7	-	-	-	-	-	-	15.0	1092	48.1
	4000	1800	42.8	1755	59.5	1717	76.3	1684	93.0	-	-	-	-	-	-	16.0	1591	69.8
612	1170	501	12.4	459	18.5	423	24.5	391	30.5	363	36.5	-	-	-	-	13.0	373	19.4
	1750	843	19.4	801	28.4	765	37.4	734	46.4	705	55.4	666	68.9	-	-	15.0	669	33.8
	3000	1581	37.7	1538.4	53.1	1503	68.5	1471	84	1442	99.4	1404	122.6	1369	145.7	16.0	1382	63.8
616	1170	671	16.6	614	24.6	566	32.6	524	40.6	486	48.6	-	-	-	-	13.0	501	25.7
	1750	1128	25.6	1072	37.5	1024	49.4	982	61.3	943	73.2	-	-	-	-	14.0	929	41.7
	3000	2115	49.0	2058	68.8	2010	88.6	1968	108.4	1930	128.2	1878	157.9	-	-	16.0	1850	81.8
624	1170	1006	25.1	921	37.1	849	49.1	786	61.1	-	-	-	-	-	-	13.0	751	38.8
	1750	1693	39.3	1608	57.2	1536	75.0	1473	92.8	-	-	-	-	-	-	14.0	1394	63.0
	3000	3173	77.6	3088	107.3	3016	137.1	2953	166.8	-	-	-	-	-	-	16.0	2777	124.8

**Notes:**

1. Pressure ratings based on inlet air at standard pressure of 14.7 psia, standard temperature of 68° F, and specific gravity of 1.0.
2. Vacuum ratings based on inlet air at standard temperature of 68°F, discharge pressure of 30" Hg and specific gravity of 1.0.

Frame Size	A	A'	B	C	Drive shaft location		O	O'	P	P'	R	U	Keyway	AF inlet diameter	AF discharge diameter	AX	Approx. net Wt (lbs)
					D	D'											
404	8.00	11.00	8.75	18.50	11.25	7.50	16.63	13.50	12.00	15.25	9.00	1.500	.375 x .188	3.0 NPT	3.0 NPT	2.25	200
406	8.00	11.00	10.75	20.50	11.25	7.50	16.63	13.50	12.00	15.25	9.00	1.500	.375 x .188	4.0 NPT	4.0 NPT	2.25	230
409	8.00	11.00	13.75	23.50	11.25	7.50	16.63	13.00	11.00	15.25	9.00	1.500	.375 x .188	4.0 NPT	4.0 NPT	2.25	270
412	8.00	11.00	16.75	26.50	11.25	7.50	16.63	13.00	11.00	15.25	9.00	1.500	.375 x .188	6.0 FLG	6.0 FLG	2.25	330
418	8.00	11.00	22.75	32.50	11.25	7.50	16.63	13.00	11.00	15.25	9.00	1.500	.375 x .188	8.0 FLG	8.0 FLG	2.25	410
612	11.0	17.00	16.75	28.24	15.00	9.00	22.13	18.00	18.00	20.00	12.00	2.00	.500 x .250	8.0 FLG	8.0 FLG	3.00	575
616	10.00	16.00	20.75	32.44	15.00	9.00	22.00	16.25	14.50	20.00	12.00	2.000	.500 x .250	8.0 FLG	8.0 FLG	3.00	650
624	10.00	16.00	28.75	40.44	15.00	9.00	22.00	16.25	14.50	20.00	12.00	2.000	.500 x .250	10.0 FLG	10.0 FLG	3.00	775

Notes: 1. All dimensions are in inches. 2. Do not use for construction.