

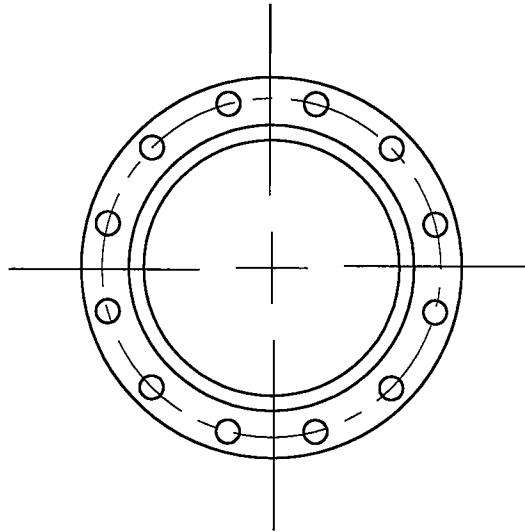

8" 150# ANSI RAISED FACE FLANGE
 BOLT HOLE CIRCLE DIAMETER = 11.75"
 BOLT HOLE DIAMETER = 0.88"
 NUMBER OF BOLTS = 8
 DIAMETER OF BOLTS = 3/4"
 THICKNESS OF FLANGE = 1.12" MIN.



10" 150# ANSI RAISED FACE FLANGE
 BOLT HOLE CIRCLE DIAMETER = 14.25"
 BOLT HOLE DIAMETER = 1.00"
 NUMBER OF BOLTS = 12
 DIAMETER OF BOLTS = 7/8"
 THICKNESS OF FLANGE = 1.19" MIN.

BOX IS BLUE IF ORIGINAL

REV	DESCRIPTION	DATE	BY
		ROTATING ENGINEERED PRODUCTS, INC. 2405 MURPHY BOULEVARD GAINESVILLE, GA. 30504 TOLL FREE: (800) 536-9933, (770) 538-0020, FAX: (770) 538-0022	
SCALE: 1-1/2" = 1'-0"		TITLE: FLANGE DETAIL FOR 8" & 12" 150# ANSI RAISED FACE FLANGE	
DRAWN BY: C HUFF	DATE: 4-24-97	MODEL/CUSTOMER	
CHECKED BY:	DATE:		
APPR BY: ACH	DATE: 7-24-97	DRAWING NO. BV022A0000	SHEET NO. 7 OF 7 REV. B