

**ROOTS****DRESSER**

# AF

2 1/2 - 7 inch gear diameter

# INSTRUCTIONS

ROTARY LOBE BLOWERS

## CONTENTS

NUMBERS IN ( ) ARE METRIC EQUIVALENTS

INFORMATION SUMMARY . . . . . This page Receiving . . . Installing . . . Operating	OPERATION . . . . . 7 Starting . . . Checking . . . Running
OPERATING CHARACTERISTICS . . . . . 2 Description . . . Control . . . Protection	SAFETY PRECAUTIONS . . . . . 7 Physical . . . Operating . . . General
OPERATING LIMITATIONS . . . . . 2 Pressure . . . Temperature . . . Speed	TROUBLE SHOOTING . . . . . 8 Capacity . . . Power . . . Heating
INSTALLATION . . . . . 3 Mounting . . . Aligning . . . Piping	MAINTENANCE/REPLACEMENTS . . . . . 9 Servicing . . . Repairs . . . Clearances
LUBRICATION . . . . . 6 Oil Fill . . . Servicing . . . Greasing	PARTS DRAWINGS . . . . . 15 DISTRIBUTORS . . . . . 16

## DO THESE THINGS . . .

## To Get The Most From Your Roots Blower

- 1** Check shipment for damage. If found, file claim with carrier and notify nearest Sales Office or factory.
- 2** Unpack shipment carefully, and check contents against Packing List. Notify Sales Office or factory if a shortage appears.
- 3** Store in a clean, dry location until ready for installation, if possible. Lift by methods discussed under INSTALLATION to avoid straining or distorting the equipment. Keep covers on all openings. Protect against weather and corrosion if outdoor storage is necessary.
- 4** Read LIMITATIONS and INSTALLATION sections in this manual and plan the complete installation.
- 5** Provide for adequate safeguards against accidents to persons working on or near the equipment during both installation and operation. See SAFETY PRECAUTIONS.

- 6** Install all equipment correctly. Foundation design must be adequate and piping carefully done. Use recommended accessories for operating protection.
- 7** Make sure both driving and driven equipment is correctly lubricated before start-up. See LUBRICATION.
- 8** Read starting check points under OPERATION. Run equipment briefly to check for installation errors and make corrections. Follow with a trial run under normal operating conditions.
- 9** In event of trouble during installation or operation, do not attempt repairs of Roots furnished equipment. Notify nearest Sales Office or factory, giving all nameplate information plus an outline of operating conditions and a description of the trouble.
- 10** Unauthorized attempts at equipment repair may void Manufacturer's warranty. Units out of warranty may be repaired or adjusted by the owner. It is recommended that such work be limited to the operations described in this manual, using Factory Parts. Good inspection and maintenance practices should reduce the need for repairs. See Distributor List on last page for parts and service after warranty period.

NOTE—Information in this manual is correct as of the date of publication. The Manufacturer reserves the right to make design or material changes without notice, and without obligation to make similar changes on equipment of prior manufacture.

## OPERATING CHARACTERISTICS

Roots Type AF blowers, as covered in this manual, range in basic frame size from 2½ inches through 7 inches gear diameter. Within each frame size are several case lengths, selected to produce reasonable steps in blower capacity ratings. The shorter lengths have lower volumetric capacities, but are capable of operating against higher pressures. All units are designated as air blowers, and may be used for handling air in either pressure or vacuum service. They are generally unsuitable for handling gases because shaft seals are not designed to prevent leakage to atmosphere.

The Roots rotary lobe blower is a positive displacement type unit, whose pumping capacity is determined by size, operating speed and pressure conditions. It employs two double-lobe impellers mounted on parallel shafts and rotating in opposite directions within a cylinder closed at the ends by headplates. As the impellers rotate, air is drawn into one side of the cylinder and forced out the opposite side against the existing pressures. **The differential pressure developed, therefore, depends on the resistance of the connected systems.**

Effective sealing of the blower inlet area from the discharge area is accomplished by use of very small operating clearances. Resulting absence of moving contacts eliminates the need for any internal lubrication. Clearances between the impellers during rotation are maintained by a pair of accurately machined timing gears, mounted on the two shafts extending outside the air chamber.

Operation of the familiar basic rotary lobe blower is illustrated in FIGURE 1, where air flow is top to bottom from inlet to discharge with the right impeller rotating clockwise. In Position 1 it is delivering a known volume (A) to the discharge, while space (B) between the left impeller and cylinder wall is being filled. Counterclockwise rotation of this impeller then traps equal volume (B) in Position 2, and further rotation delivers it to the discharge in Position 3. At the same time, another similar volume is forming beside the right impeller, and will be discharged when rotation reaches Position 1 again.

One complete revolution of the driving shaft alternately traps four equal and known volumes of air (two by each impeller) and pushes them through to the discharge. The pumping capacity of a lobe blower operating at a constant speed therefore remains relatively independent of reasonable inlet or discharge pressure variations.

To change capacity, it is necessary either to change speed of rotation or vent some of the air.

No attempt should ever be made to control capacity by means of a throttle valve in the intake or discharge piping. This increases the power load on the driver, and may seriously damage the blower. Likewise, if a possibility exists that flow to the blower inlet may be cut off during normal operation of a process then an adequate vacuum relief valve must be installed near the blower. A pressure type relief valve in the discharge line near the blower is also strongly recommended for protection against cut-off or blocking in this line.

When a belt drive is employed, blower speed can usually be adjusted to obtain desired capacity by changing the diameter of one or both sheaves. In a direct coupled arrangement, a variable speed motor or transmission is required, or air may be vented through a manually controlled unloading valve and silencer. If discharge air is returned to the blower inlet, it **must** be cooled to 100°F. (38°C) through a cooling by-pass arrangement.

**Before making any change in blower capacity or operating conditions,** contact the nearest Sales Office for specific information applying to your particular blower. In all cases, operating conditions **must** be maintained within the approved range of pressures, temperatures and speeds as stated under LIMITATIONS. Also, the blower *must not* be used to handle air containing liquids or solids. Serious damage to the rotating parts will result.

## OPERATING LIMITATIONS

To permit continued satisfactory performance, a Roots Type AF blower must be operated within certain approved limiting conditions. The Manufacturer's warranty is, of course, also contingent on such operation.

Maximum limits for pressure temperature and speed are specified in Table 1 for various sizes of AF blowers. These limits apply to all blowers of normal construction, having operating clearances as listed in Table 5 when operated under standard atmospheric conditions. **Do not exceed any of these limits.**

**Example:** The listed maximum allowable temperature rise (increase in air temperature between inlet and discharge) for any particular blower may occur well before its maximum pressure or vacuum rating is reached. This can easily occur at high altitude or at very low speed. *Temperature rise then is the limiting condition.* In other words, the operating limit is always determined by the

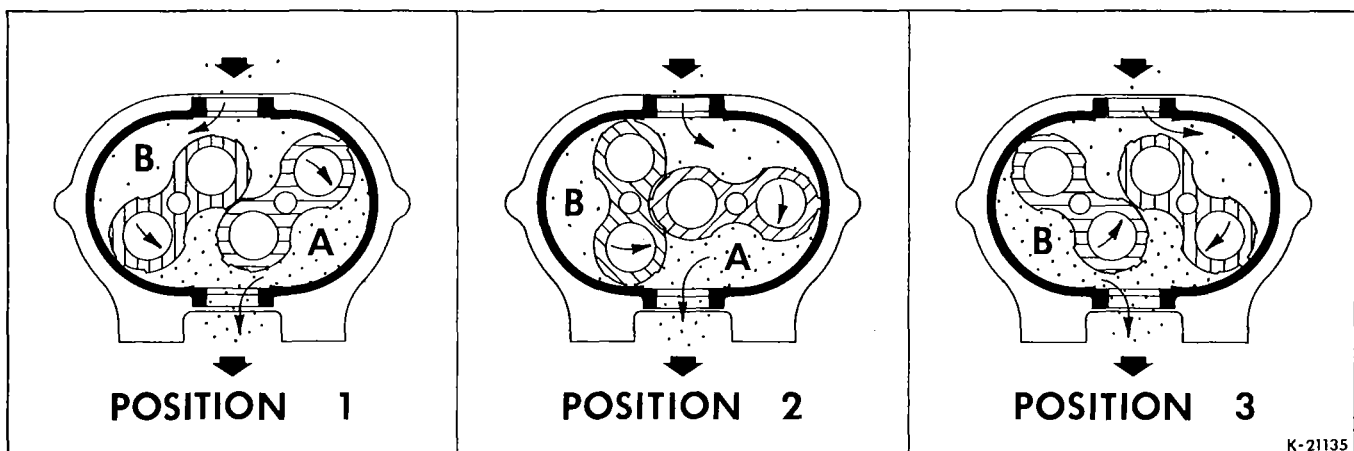

Figure 1 - Flow Through a Basic Type AF Blower

K-21135

maximum rating reached first. It can be any one of the three: pressure, temperature or speed.

Be sure to arrange connections or taps for thermometers and mercury type pressure or vacuum gauges at or near the inlet and discharge connections of the blower. These, along with a good tachometer, will enable periodic checks of operating conditions to be made easily.

**PRESSURE** — On pressure service, the pressure rise in pounds per square inch (kPa) between blower inlet and discharge must not exceed the figure listed for the specific blower frame size concerned. Also, in any system where the blower inlet is at a positive pressure above atmosphere, the discharge pressure must never exceed 25 PSI (172 kPa) gauge regardless of blower size.

On vacuum service, with the discharge going to atmospheric pressure, the inlet suction or vacuum in inches of mercury (kPa) must not be greater than the values listed for the specific frame size.

**TEMPERATURE** — Various blower frame sizes are approved only for installations where the following temperature limitations can be maintained in service.

- A. Measured temperature rise in Fahrenheit degrees (C°) must not exceed listed values when the inlet is at ambient temperature. Ambient is considered as the general temperature of the space around the blower. This is not outdoor temperature unless the blower is installed outdoors.
- B. If inlet temperature is higher than ambient, the listed allowable temperature rise values must be reduced by 2/3 of the difference between the actual measured inlet temperature and the ambient temperature.
- C. Average of inlet plus discharge temperature must not exceed 250°F (121°C). Maximum allowable discharge temperature is 400°F (204°C).

**SPEED RANGE**—AF blowers may be operated at speeds up to the maximums listed for the various frame sizes. They may be direct coupled to suitable constant speed drivers if pressure/temperature conditions are also within limits. At low speeds, excessive temperature rise may be the limiting factor as noted in the preceding example.

Frame Size	Speed RPM	Inlet Vac. Inches HG. (kPa)	Temp. Rise Fahr. Deg. (C°)	Press. Rise PSI (kPa)
22	2600	10(34)	332(184)	6.0(41)
24	"	7(24)	185(103)	3.5(24)
315	1850	10(34)	332(184)	8.0(55)
33	"	10(34)	190(106)	6.0(41)
36	"	7(24)	115( 64)	3.5(24)
42	1620	12(40)	240(133)	10.0(69)
44	"	10(34)	165( 92)	6.0(41)
47	"	7(24)	90( 50)	3.5(24)
53	1300	12(40)	160( 89)	10.0(69)
55	"	10(34)	120( 67)	6.0(41)
59	"	7(24)	65( 36)	3.5(24)
65	1080	12(40)	230(128)	10.0(69)
67	"	12(40)	155( 86)	6.0(41)
610	"	10(34)	115( 64)	6.0(41)
615	"	7(24)	75( 42)	3.5(24)
76	925	12(40)	245(136)	10.0(69)
710	"	12(40)	145( 81)	6.0(41)
717	"	7(24)	85( 47)	3.5(24)

Table 1-Maximum Allowable Operating Conditions

## INSTALLATION

Roots Type AF Blowers are internally and externally treated after factory assembly to protect against normal atmospheric corrosion before installation. Maximum period of internal protection is considered to be one year under average conditions, if closing plugs or seals are not removed. **Protection against chemical or salt water atmosphere is not provided.** Avoid opening the blower until ready to start installation, as protection will be lost quickly by evaporation.

**NOTE** — If there is to be an extended period between installation and startup, the following steps should be taken to insure corrosion protection:

1. Coat internals of cylinder and gearbox with Motorstor or equivalent. Repeat once a year or as conditions may require. Motorstor is oil soluble and does not have to be removed before lubricating. If desired, Motorstor may be removed from within the cylinder shortly before startup by spraying a fine mist of petroleum solvent through the blower while it is running at a slow speed with open inlet and discharge, or it can remain in the blower if it is not harmful to the operation of the connected system. Motorstor is a product of Daubert Chemical Co., 2000 Spring Rd., Oak Brook, Ill. 60521.
2. Fill drive end bearing cavities with grease as specified in Lubrication section.
3. Paint shaft extension, inlet and discharge flanges, and all other exposed surfaces with Nox-Rust X-145 or equivalent.
4. Seal inlet, discharge, and all vent openings with tape. It is **not** recommended that the unit be set in place, piped to the system, and allowed to remain idle for extended periods. If any part is left open to the atmosphere, the Motorstor vapor will escape and lose its effectiveness.
5. Units are not to be subjected to excessive vibration during storage. If stored outdoors, provide coverage such as a tarpaulin or lean-to.
6. Rotate drive shaft three or four revolutions every two weeks.
7. Prior to startup, remove flange covers on both inlet and discharge and inspect internals to insure absence of rust. Check all internal clearances. Also, at this time, remove gearbox and inspect gear teeth for rust.

Because of the completely enclosed blower design, location of the installation is generally not a critical matter. A clean, dry and protected indoor location is to be preferred. However, an outdoor or wet location will normally give satisfactory service. Important requirements are that the correct grade of lubricating oil be provided for expected temperatures, and that the blower be located so that routine checking and servicing can be handled conveniently after installation. Effect of the location on driver and accessory equipment must also be considered.

Supervision of the installation by a Factory Service Engineer is not usually required for these blowers of 2½" through 7" gear diameter. Workmen with experience in installing light-medium weight machinery should be able to produce satisfactory results. Handling of the equipment needs to be accomplished with care, and in compliance with safe practices. Blower mounting must be solid, without strain or twist, and air piping must be clean, accurately aligned and properly connected.

A bare blower without base should be lifted by a rope sling, with one loop passing under the gearhouse and the other loop under the cylinder.

When a blower is furnished *mounted on a baseplate*, with or without a driver, use of lifting slings passing under the base flanges is required. Arrange these slings so that no strains are placed on the blower casing or mounting feet, or on any mounted accessory equipment.

Before starting the installation, remove plugs, covers or seals from blower inlet and discharge connections and inspect the interior completely for dirt or foreign material. If cleaning is required, finish by washing the cylinder, headplates and impeller thoroughly with a petroleum solvent such as DuPont Triclene D. After this, turn the drive shaft by hand to make sure that the impellers turn freely at all points. Anti-rust compound on the drive shaft extension may also be removed at this time with the same solvent. Then plug the inlet and discharge connections to keep out dirt until ready to connect the air piping. Washing out is not required if the interior is found to be clean. The corrosion inhibitor used will vaporize and disappear during operation.

Care, plus consideration of all possible problems, will pay dividends when arranging the blower mounting. This is especially true when the blower is a "bare" unit, furnished without a baseplate. The convenient procedure may be to mount such a unit directly on a floor or small concrete pad, but this generally produces least satisfactory results. It definitely causes the most problems in leveling alignment.

Direct use of structural framing members is also not a recommended mounting. If unavoidable, the members must be rigidly reinforced when part of a building, and spring type mountings should not be used. Noise transmission can usually be reduced by use of a cork insulating pad 1 to 2 inches (25 to 50 mm) thickness. The pad should be supported by a full steel plate attached to the structure, with a rigid concrete slab laid on top of the cork to carry the blower and driver.

For a blower without base, it is recommended that a well anchored and carefully leveled steel or cast iron mounting plate be provided at the installation point. The plate should be 3/4 to 1-1/4 inches (19 to 32 mm) thick, with its top surface machined flat, and needs to be large enough to provide leveling areas at one side and one end after the blower is mounted. It should have properly sized studs or tapped holes located to match the blower foot drilling. As an alternative, smaller plates at each end of the blower may be used. This is more complicated, usually makes leveling more difficult, and can produce twist or strains in the blower. Use of a high quality machinist's level is important.

With the mounting plate in place leveled, set the blower on it without bolting and check for rocking. If it is not solid, determine the total thickness of shims required under one foot to stop the rocking. Place half of this under each of the two short feet, and tighten the mounting studs or screws. Rotate the drive shaft to make sure the impellers still turn freely. If the blower is to be direct coupled to a driving motor, consider the height of the motor shaft and the necessity for it to be aligned very accurately with the blower shaft. Best arrangement is for the blower to be bolted directly to the mounting plate while the driver is on shims of at least 1/8 inch (3 mm) thickness. This allows adjustment of motor position in final shaft alignment by varying the shim thickness.

Satisfactory installation can be obtained by setting the baseplate on a concrete slab that is rigid and free of

vibration, and leveling the top of the base carefully in two directions so that it is free of twist. The slab must be provided with suitable anchor bolts. The use of grouting under and inside the base, after it has been carefully leveled by shimming, is recommended.

When blower and driver have been factory mounted on a common baseplate, the assembly will have been properly aligned and is to be treated as a unit for leveling purposes. It is possible for a base-mounted assembly to become twisted during shipment, thus disturbing the original alignment. For this reason, make the following checks after the base has been leveled and bolted down. Disconnect the drive and rotate the blower shaft by hand. It should turn freely at all points. Loosen the blower foot hold-down screws and determine whether all feet are evenly in contact with the base. If not, insert shims as required and again check for free impeller rotation. Finally, if blower is direct coupled to the driver, check shaft and coupling alignment carefully and make any necessary corrections prior to grouting.

In planning the installation, and before setting the blower, consider how piping arrangements are dictated by the blower design and assembly.

#### DIRECTION OF ROTATION

*BLOWERS WITH* Serial Number beginning with "48" or later may be operated in either direction without retiming of gears. Older blowers should not be reversed without resetting gears.

*STANDARD ASSEMBLY* of blowers has drive shaft on left when facing drive end of blower. For top outlet, the drive shaft will turn clockwise; for bottom outlet, counterclockwise. When blower has drive shaft on right side, the opposite rotations would apply.

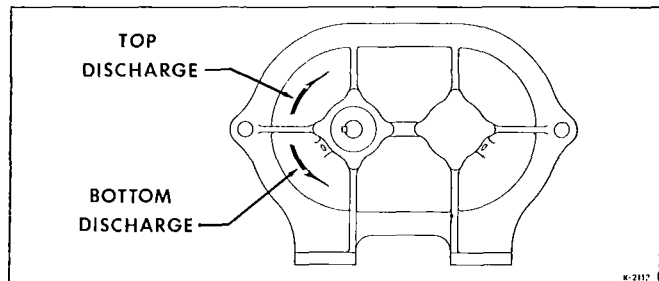

Figure 2 - Piping Connections for Different Shaft Rotations

When a blower is **DIRECT COUPLED** to its driver, the driver, RPM must be selected or governed so as not to exceed the maximum speed rating of the blower. Refer to **LIMITATIONS** for allowable speeds for various blower sizes. A *flexible* type coupling should always be used to connect the driver and blower shafts.

Coupling halves must be accurately aligned, and a sufficient gap between shaft ends provided, so that side strains and end thrust on either shaft are avoided or minimized. This will require considerable care in the mounting of the driver. The two shafts must be in as near perfect alignment in all directions as possible, and the gap must be established with the motor armature on its electrical center if end play exists. Coupling halves must be fitted to the two shafts so that only light tapping is required to install them. Maximum deviation in offset alignment of the shafts should not exceed .005" (.13 mm) Total indicator reading, taken on the two coupling hubs. Maximum deviation from parallel of the inside coupling faces should not exceed .001" (.03 mm) when checked at six points around the coupling.

When a blower is BELT DRIVEN, a proper selection of sheave diameters can usually be made to adapt any standard driver speed to the required blower speed. This flexibility can sometimes lead to operating temperature problems caused by blower speed being too low. Make sure the drive speed selected is within the allowable range for the specific blower size, as specified under LIMITATIONS.

Belted drive arrangements usually employ two or more V-belts running in grooved sheaves, and a variety of positions are available for the driver. Installation of the driver is less critical than for direct coupling, but its shaft must be level and parallel with the blower shaft. The driver must also be mounted on an adjustable base to permit installing, adjusting and removing the V-belts. To position the driver correctly, both sheaves need to be mounted on their shafts and the nominal shaft center distance known for the belt lengths to be used.

Install the blower sheave (usually the larger one) so that its inner hub face is not more than 1/4 inch (7 mm) from the bearing end cover. The shaft fit should be such that the sheave can be worked into place by hand or by very light tapping. A tight or driving fit can damage a bearing, and may cause internal blower damage by forcing the impeller out of its normal operating position. A loose fit or wobbly sheave will cause vibration, and may result in shaft breakage.

The driver sheave should also be mounted as close to its bearing as possible, and again should fit the shaft correctly. Position the driver on its adjustable base so the 2/3 of the total movement is available in the direction away from the blower, and mount the assembly so that the face of the sheave is accurately in line with the blower sheave. This position minimizes belt wear, and allows sufficient adjustment for both installing and tightening the belts. After belts are installed, adjust their tension in accordance with the manufacturer's instructions. However, only enough tension should be applied to prevent slippage when the blower is operating under load. *Excessive tightening* can lead to early bearing failures.

Failure to properly align the blower and driver sheaves will result in the impeller being forced against one of the headplates during operation causing serious damage to the blower.

In the absence of belt manufacturer's instruction for tensioning, the following procedure may be used.

1. With the belts loose, pull the slack on all of them to the bottom side of the drive.
2. Adjust motor position to tighten belts until they appear to be seating in the sheave grooves.
3. Thump the belts with your fist. If they feel dead, tighten them more until they vibrate and feel springy when struck.
4. Run-in the drive for a short period, after preparing the blower as instructed in a following paragraph. While running, adjust until only a very slight bow appears in the slack side of the belts.
5. Stop the motor and compare the tensions of the individual belts by pressing down firmly with one hand on the top surface. It should be possible to deflect each belt only to the point where its top surface is even with the bottoms of the other undeflected belts.
6. A new set of belts should be first tensioned about 1/3 greater than normal to allow for stretch and wear-in. Before putting the drive into normal operation, increase the tension as obtained above by a small amount. Recheck after each 8 hour operating period during the first 50 hours, and adjust as necessary.

Before operating the drive under power to check initial belt tension, first remove covers from the blower connections. Make sure the interior is still clean, then rotate the shaft by hand. Place a screen over the inlet connection to prevent anything being sucked into the blower while it is operating, and avoid standing in line with the discharge opening. Put oil in the gearhouse per instructions under LUBRICATION.

Before connecting PIPING, remove any remaining anti-rust compound from blower connections. Pipe used should be no smaller than these connections, and clean, new piping throughout is strongly recommended. In addition, make sure it is free of dirt, scale, cuttings, weld beads, or foreign materials of any kind. To further guard against damage to the blower, especially when an inlet filter is not used, install a substantial screen of 16 mesh backed with hardware cloth at or near the inlet connections. Make provisions to clean this screen of collected debris after a few hours' operation. It should be removed when its usefulness has ended, as the wire will eventually deteriorate and small pieces going into the blower may cause serious damage.

Pipe threads *must* meet the blower connections accurately and squarely. *Do not* attempt to correct misalignment by springing or cramping the pipe. In most cases this will distort the blower casing and cause impeller rubbing. In severe cases it can prevent operation or result in a broken drive shaft. For similar reasons, piping should be supported near the blower to eliminate dead weight strains. Also, if pipe expansion is likely to occur from temperature change, installation of flexible connectors or expansion joints is advisable.

Figure 3 represents in diagram form a blower installation with all accessory items that might be required under various operating conditions. Inlet piping should be completely free of valves or restrictions. When a shut-off valve (not shown) cannot be avoided, make sure a full size vacuum relief is installed near the blower inlet. This will protect against blower overload caused by accidental closing.

Need for an inlet silencer will depend on blower speed and pressure, as well as sound-level requirements in the

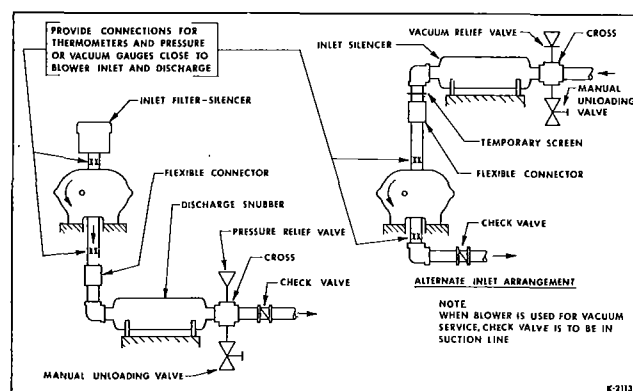

Figure 3 - Installation with Accessories

general surroundings. An inlet filter is normally *recommended*, especially in dusty or sandy locations, for blower protection. A discharge silencer is also normally *suggested*. Specific recommendations on silencing can be obtained from the nearest Sales Office.

Discharge piping requires a pressure relief valve, and should include a manual unloading valve to permit starting

the blower under no-load conditions. Reliable pressure/vacuum gauges and good thermometers at both inlet and discharge are *recommended* to allow making the important checks on blower operating conditions. If the demand is constant, but somewhat lower than the blower output, excess may be blown off through the manual unloading valve.

In multiple blower installation when two or more units discharge into a common header, use of check valves is *recommended*. These should be of a direct acting or free swinging type, with one valve located in each blower discharge line. Properly installed, they will protect against damage from reverse rotation caused by air back-flow through an idle blower.

After piping is completed, and before applying power, rotate the drive shaft by hand again. If it does not move with uniform freedom, look for uneven mounting, piping strain, excessive belt tension or coupling misalignment. Do not operate the blower more than briefly at this time because of possible inadequate oil supply in the gearhouse. Read LUBRICATION section.

## LUBRICATION

Shaft bearings at the gear end of the blower are splash lubricated by both gears dipping into an oil sump located in the gearhouse. **Before starting the blower**, fill this sump as instructed below. Recommended oils for various operating conditions are listed in Table 2. Quantities required to fill sumps in the different blower frame sizes, are listed in Table 3. Use a good grade industrial type rust, oxidation, and foam inhibited non-detergent oil.

Ambient Temperature	Pressure Rise-PSI (kPa)	Viscosity SSU at 100°F (38°C)	Approx. cSt SAE at 40°C	
Below 90°F (32°C)	Below 2.0 (14)	500- 700	30	96-135
Over 90°F (32°C)	Below 2.0 (14)	700-1000	40	135-192
Below 90°F (32°C)	Over 2.0 (14)	700-1000	40	135-192
Over 90°F (32°C)	Over 2.0 (14)	1000-1200	50	192-230

Table 2 - Recommended Oil Grades

Frame Size	Capacity Fl. Oz. (Liters)
2½"	4 (.12)
3½"	6 (.18)
4"	10 (.30)
5"	15(.44)
6"	26 (.77)
7"	38 (1.12)

Table 3 - Oil Sump Capacities

To fill oil sump, remove breather and oil fill plug and oil level pipe plug in the gearhouse, as indicated Figure 4. Fill until oil starts to run out from the oil level hole, then clean and replace the breather and oil fill plug. **DO NOT** replace the oil level plug until the oil has stopped running out. This avoids over-lubrication, as too much oil causes heating and oil leakage.

When blower is being operated, check gear house oil levels regularly at shutdown periods, and add oil if needed, **Do not check or fill while running**. Change oil every 2000 operating hours, or more frequently depending on the type of oil and ambient conditions.

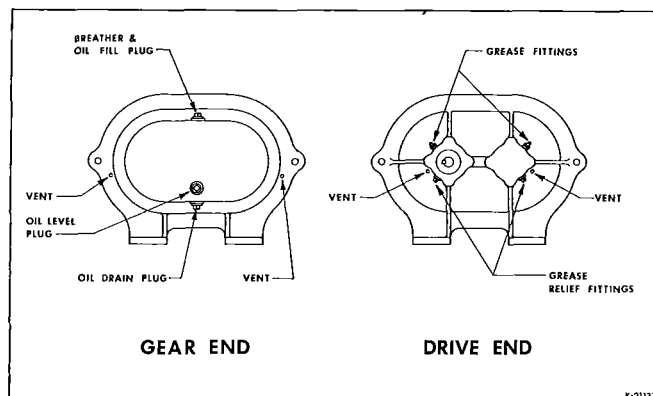

Figure 4 - Lubrication Points

Shaft bearings at the drive end of the blower are grease lubricated and each bearing housing is equipped with pressure type grease fittings and pressure type relief fittings. Using a good quality grease of NLGI Grade 2 in a pressure gun, force new lubricant into each drive end bearing housing until traces of clean grease appears coming out of the relief fitting.

After a long shutdown, it is recommended that the grease relief fittings be removed. The old grease must be flushed out with #10 lubricating oil or kerosene, bearing housing drained thoroughly, and bearings refilled with new grease. Be sure grease relief fittings are reinstalled.

Grease should be added to the drive end bearings at the initial start-up and at varying time intervals depending on duty cycle and RPM. Table 4 has been prepared as a general greasing schedule guide based on average operating conditions.

Speed in RPM	Operating Hours Per Day		
	8	16	24
Greasing Intervals in Weeks			
750-1000	7	4	2
1000-1500	5	2	1
1500-2000	4	2	1
2000-2500	3	1	1
2500-3000	2	1	1

Table 4 - Suggested Bearing Lubrication Intervals

## OPERATION

Before operating a blower under power for the first time, recheck the unit and the installation thoroughly to reduce the likelihood of avoidable troubles. Use the following procedure list as a guide, but consider any other special conditions in the installation.

1. **Be certain** that no bolts, tools, rags or dirt have been left in the blower air chamber.
2. **Be certain** that inlet piping is free of debris. If an outdoor intake without filter is used be sure the opening is located so it cannot pick up dirt and is protected by a strong screen or grille. Use of the *temporary* protective screen at the blower as described under INSTALLATION is strongly recommended.
3. **Recheck blower leveling, drive alignment and tightness** of all mounting bolts if installation is not recent. If belt drive is used, adjust belt tension correctly.
4. Turn drive shaft by hand to make sure impellers still rotate without bumping or rubbing at any point.
5. **Make sure** oil level in blower gearbox is correct.
6. Check lubrication of driver. If it is an electric motor, be sure that power is available and that electrical overload devices are installed and workable.
7. Open the manual unloading valve in the discharge air line. If a valve is in the inlet piping, be sure it is open.
8. Bump blower a few revolutions with driver to check that direction of rotation agrees with piping connections shown in Fig. 2, and that both units coast freely to a stop.

After the preceding points are cleared, blower is ready for trial operation under "no-load" conditions as set up under Item 7. The following procedure is suggested to cover this initial operating test period.

- a. Start blower, let it accelerate to full speed, then shut off. Listen for knocking sounds, both with power on and as speed slows down.
- b. Repeat above, but let blower run 2 or 3 minutes. Check for noises, and vibrations of 5 mils or greater.
- c. Operate blower for about 10 minutes unloaded. Check oil levels. Feel cylinder and headplate surfaces for development of spots too hot to touch, indicating impeller rubs. Be aware of any noticeable increase in vibration.

Assuming that all trials have been satisfactory, or that necessary corrections have been made, the blower should now have a final check run of at least one hour under normal operating conditions. After blower is restarted, gradually close the discharge unloading valve to apply working pressure. At this point it is recommended that a good pressure gauge or manometer be connected into the discharge line if not already provided, and that thermometers be in both inlet and discharge lines. Readings from these instruments will show whether pressure or temperature ratings of the blower are being exceeded.

During the final run, check operating conditions frequently and observe the oil levels at reasonable intervals. If excessive noise or local heating develops, shut down immediately and determine the cause. If either pressure rise or temperature rise across the blower *exceeds the limit specified in this manual* shut down and investigate conditions in the piping system or in the process to which air is being supplied. Refer to the TROUBLE SHOOTING CHECKLIST for suggestions on various problems that may appear.

The blower should now be ready for continuous duty operation at full speed. During the first few days make periodic checks to determine whether all conditions remain steady, or at least acceptable. This may be particularly important if the blower is supplying air to a process system where conditions can vary. At the first opportunity, stop the blower and clean the temporary inlet protective screen. If no appreciable amount of debris has collected, the screen may be removed. See comments under INSTALLATION. At this same time, verify leveling, coupling alignment or belt tension, and mounting bolt tightness.

Should operating experience prove that blower capacity is a little too high for the actual air requirements, a *small* excess may be blown off continuously through the manual unloading or vent valve. **Never rely on the pressure relief valve as an automatic vent.** Such use may cause the discharge pressure to become excessive, and can also result in failure of the valve itself. If blower capacity appears to be too low, refer to the TROUBLE SHOOTING CHECKLIST, first. If no help is found there it may be possible to increase the blower speed. Before attempting this change, contact the nearest Sales Office for recommendations. Be prepared to furnish data on actual air requirements and operating pressure/temperature conditions.

## SAFETY PRECAUTIONS

For equipment covered specifically or indirectly in this instruction book, it is important that all personnel observe safety precautions to minimize the chances of injury. Among many considerations, the following should particularly be noted.

- Blower casing and associated piping or accessories may become hot enough to cause major skin burns on contact.
- Internal and external rotating parts of the blower and driving equipment can produce serious physical injuries. Do not reach into any opening in the blower while it is operating, or while subject to accidental starting. Cover external moving parts with adequate guards.
- Disconnect power before doing any work, and avoid by-passing or rendering inoperative any safety or protective devices.
- If blower is operated with piping disconnected, place a strong coarse screen over the inlet and avoid standing in the discharge air stream. Stay clear of open inlet piping (suction area) of pressure blowers, and the open discharge blast from vacuum blowers.

## TROUBLE SHOOTING CHECKLIST

TROUBLE	ITEM	POSSIBLE CAUSE	REMEDY
No Air Flow	1	Speed too low	Check by tachometer and compare with speed shown on Roots Order Acknowledgment. Compare actual rotation with Figure 2. Change driver if wrong. Check piping, screen, valves, silencer, to assure an open flow path.
	2	Wrong rotation	
	3	Obstruction in piping	
Low Capacity	4	Speed too low	See item 1. If belt drive, check for slippage and readjust tension. Check inlet vacuum and discharge pressure, and compare these figures with specified operating conditions on Order. See item 3. Check inside of casing for worn or eroded surfaces causing excessive clearances.
	5	Excessive pressure	
	6	Obstruction in piping	
	7	Excessive slip	
Excessive Power	8	Speed too high	Check speed and compare with Roots Order Acknowledgment. See item 5. Inspect outside of cylinder and headplates for high temperature areas, then check for impeller contacts at these points. Correct blower mounting, drive alignment.
	9	Pressure too high	
	10	Impellers rubbing	
Overheating of Bearings or Gears	11	Inadequate lubrication	Restore correct oil levels in gearbox and lubricate drive end bearings. Check gear oil level. If incorrect, drain and refill with clean oil of recommended grade. See item 5. Check carefully. Realign if questionable. Readjust for correct tension. Speeds lower than the minimum recommended will overheat the entire blower.
	12	Excessive lubrication	
	13	Excessive pressure rise	
	14	Coupling misalignment	
	15	Excessive belt tension	
	16	Speed too low	
Vibration	17	Misalignment	See item 14. See item 10. Check gear backlash and condition of bearings. Scale or process material may build up on casing and impellers, or inside impellers. Remove build-up to restore original clearances and impeller balance. Tighten mounting bolts securely. Determine whether standing wave pressure pulsations are present in the piping. Refer to Sales Office.
	18	Impellers rubbing	
	19	Worn bearings/gears	
	20	Unbalanced or rubbing impellers	
	21	Driver or blower loose	
	22	Piping resonances	



- Stay clear of the blast from pressure relief valves and the suction area of vacuum relief valves. Avoid extended exposure in close proximity to machinery which exceeds safe noise levels.
- Use proper care and good procedures in handling, lifting, installing, operating and maintaining the equipment.
- Casing pressure must not exceed 25 PSI (172 kPa) gauge. Do not pressurize vented cavities from an external source, nor restrict the vents.
- Do not use air blowers on explosive or hazardous gases.
- Other potential hazards to safety may also be associated with operation of this equipment. All personnel working in or passing through the area should be warned by signs and trained to exercise adequate general safety precautions.

## MAINTENANCE & REPLACEMENTS

A good program of inspection and maintenance servicing, followed consistently, is the most reliable method of minimizing repairs to a blower. A simple record of services and dates will help keep this work on a regular schedule. Basic service needs are lubrication, checking for hot spots or increase in vibration and noise, and the recording of operating pressures and temperatures. Above all, a blower must be operated within its specified rating limits to obtain satisfactory service life.

A newly installed blower should be checked frequently during the first month of full-time operation. Attention thereafter may be less frequent, depending on what the early checks have shown. Lubrication is normally the most important consideration. Unless operating conditions are unusually severe, a weekly check of oil levels in the gearbox, with addition of oil as required, should be sufficient. Complete oil changes should be made at intervals of 2000 operating hours, or more frequently if oil condition becomes poor.

Driver lubrication practices should be in accordance with the manufacturer's instructions. If direct connected to the blower through a lubricated type coupling, the coupling should be checked and greased each time blower oil is changed. This will help reduce wear and prevent it from causing vibration. In a belted drive system, check belt tension periodically and inspect for frayed or cracked belts. Refer to tensioning instructions under INSTALLATION.

In a new and properly installed blower there are no moving contacts between the two impellers, or between the impellers and cylinder or headplates. Wear is then confined to the bearings which support and locate the shafts, the shaft seals, and the timing gears. All are lubricated, and wear should be nominal if clean oil of the correct grade is always supplied. Seals are subject to deterioration as well as wear, and may require replacement at varying periods.

Shaft bearings have been selected to have optimum life under average conditions with proper lubrication. They are critical in the service life of the blower. Gradual bearing wear may allow a shaft position to change slightly, until rubbing develops between impeller and cylinder headplate.

This will cause spot heating, which can be detected by feeling these surfaces. Sudden bearing failure is usually more serious. Since the shaft and impeller is no longer supported and properly located, extensive general damage to the blower casing and gears is likely to occur.

Shaft seals should be considered expendable items, to be replaced whenever drainage from the headplate vent cavity becomes excessive, or when the blower is disassembled for any reason. Sealing effectiveness can vary considerably from seal to seal, and is also affected to a surprising degree by shaft smoothness and freedom from scratches under the seal lip. Because of these normal variables, minor seal leakage should not be considered as indicating a need for replacement.

Timing gear wear, when correct lubrication is maintained, should be negligible over a period of years. Gear teeth are cut to provide the correct amount of backlash, and gears correctly mounted on the shafts will accommodate a normal amount of tooth wear without permitting contact between lobes of the two impellers.

However, a high oil level will cause churning and excessive heating, indicated by an unusually high temperature at the bottom of the gear housing. Consequent heating of the gears will result in loss of tooth clearance or backlash, and rapid wear of the gear teeth usually will develop. Continuation of this tooth wear will eventually produce impeller contacts (knocking), and from this point serious damage will be unavoidable if blower operation is continued. A similar situation can be produced suddenly by gear tooth fracture, which is usually brought on by sustained overloading or momentary shock loads.

Operating problems may also develop from causes other than internal parts failure. Operating clearances within a blower are only a few thousandths of an inch (hundredths of a mm). This makes it possible for impeller interferences or casing rubs to result from shifts in the blower mounting, or from changes in piping support. Foreign materials sucked into the blower will also cause trouble, which can only be cured by disconnecting the piping and thoroughly cleaning the blower interior.

If this type of trouble is experienced, and the blower if found to be clean, try removing mounting strains. Loosen blower mounting bolts and reset the leveling and drive alignment. Then tighten mounting again, and make sure that all piping meets blower connections accurately and squarely before reconnecting it.

A wide range of causes for operating troubles are covered in the TROUBLE SHOOTING CHECKLIST. The remedies suggested there in some cases need to be performed by qualified mechanics with a good background of general experience, using procedures detailed in this manual. Major repairs generally are to be considered beyond the scope of maintenance, and should be referred to the nearest Sales Office listed on the last page.

Warranty failures should not be repaired at all, unless specific approval has been obtained through a Sales Office before starting work. Unauthorized disassembly within the warranty period may void the warranty.

When a blower is taken out of service it may require internal protection against rusting or corrosion. The need for such protection must be a matter of judgment based on existing conditions as well as length of downtime. Under favorable conditions, protection will probably not be

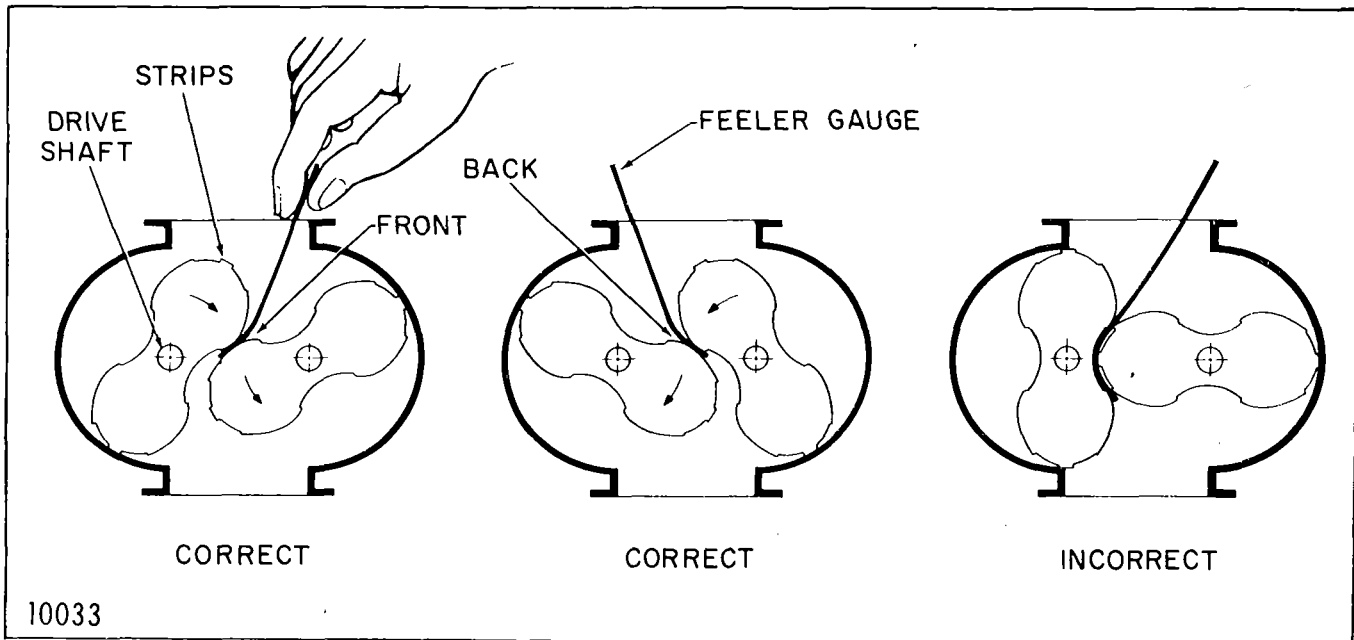

Figure 5 - Identification of Front and Back Impeller Clearances, and Method of Using Feeler Gauge

needed if shut-down is not longer than a month. Under atmospheric conditions producing rapid corrosion, the blower should be protected immediately. If blower is to be shut-down for an extended period of time, see suggestions for corrosion protection under installation.

It is *recommended* that major repairs, if needed, be performed by the Factory or an authorized Roots Distributor. However, it is recognized that this may not always be practical, especially when a spare blower is not available. If a blower is out of the warranty period, mechanical adjustments and parts replacement may be undertaken locally at the owner's option and risk. It is recommended that Factory Parts be used to insure fit and suitability. The maintenance of a small stock of on-hand spare parts can eliminate possible delays. When ordering parts give Item Numbers and their word descriptions from Figure 6 and Table 6. Also specify quantities wanted, and the blower size and serial number from the nameplate.

Repairs or adjustments are best performed by personnel with good mechanical experience and the ability to follow the instructions in this manual. Some operations involve extra care and patience, and a degree of precision work. This is especially true in timing impellers and in handling bearings. Experience indicates that a high percentage of bearing failure is caused by dirt contamination before or during assembly. Therefore, the work area should be cleaned before starting disassembly, and new or re-usable parts protected during progress of the work.

In the following outlines of repair procedures, numbers shown in brackets ( ) correspond to the Item Numbers used in assembly drawing, Figure 6, and parts list, Table 6. It is recommended that the procedures be studied carefully and completely, with frequent reference to the drawings, before starting work. This will produce better efficiency through an understanding of what work is to be done, and

the order of doing it. *Before disassembly, mark all parts so that they may be returned to original locations or relative positions.*

#### A—Replacing Timing Gears

1. Drain all oil from the gearhouse by removing bottom plug (23). Remove gearhouse by taking out all cap screws (18) in its flange. It may be necessary to bump the sides with a wood block or mallet to break the flange joint.
2. On the exposed end of each shaft make a punch mark near the edge and exactly in line with the large end of the gear taper pin. This will locate the taper pin hole, because the gears must be re-pinned at a right angle to the old hole. This is discussed further in Step 11. Reach through one of the blower pipe connections and place a chalk mark on the lobe of one impeller and the mating waist of the other, so that they may easily be returned to their original relative positions.
3. Support each gear hub in turn on a block and drive out the taper pins from the small end, turning the gears as necessary. Remove the gears by means of a gear puller, which clamps around the grooved gear hub. Do not attempt to remove the gears by other means, such as bumping, as this will cause damage to impellers or bearings.
4. Remove any burrs on the shafts, but do not work them down to make a looser gear fit. Also check the shaft holes in the new gears for burrs, and wipe clean. Be sure gears are matched pair (with same numbers). Using white lead mixed with machine oil, or a heavy grade of oil alone, coat the shafts and the inside of shaft holes in the gears.

5. Make sure impellers are in correct position as previously marked. Start a gear on the driving shaft with hub facing away from the headplate. Carefully drive the gear until it is about 1/4 in. (7 mm) away from seating against the shaft shoulder.

6. Place second gear on other shaft in same manner. **Match marks on gear teeth should come together when gears are rolled.** This can be checked by counting teeth on one gear and spaces on the other between the match marks and the present meshing point.

7. Rotate the impellers to make sure they do not bump, then measure front and back lobe clearances with feelers when impellers are in positions shown in Figure 5. These two clearances should be equal when the impellers are properly "timed" and should be within the theoretical limit given in Table 5.

8. If not equal, add the two clearances and divide by 2 to determine the correct clearance. Add 0.003 in. (.08 mm) to the result and wedge feelers of the total amount tightly between the lobes in the closer position (front or back). This can be done by rotating the gears sharply. Bump both gears so they move about 1/64 in. (.4 mm) along the shafts. This will "slip" one or both gears and change the lobe clearances.

9. Recheck front and back clearances. If not equal, repeat Step 8 until correct. It is very important that the impeller timing be accurately done. Finally, drive both gears up to their shaft shoulders while continuing to check that the equal clearances are maintained.

10. Wedge the gears to prevent rotation, and drill and ream a taper pin hole at a right angle to the old hole in the shaft. Ream carefully so as not to make the hole larger than necessary, but obtain a clean hole all around for good pin seating. Inspect the reamed hole by holding a light at the small end. The walls should appear bright, with no dull areas and no offsets at the shaft lines. Support the gear hub and drive a new pin firmly into the reamed hole. The large end should not go below the hub surface.

11. Repeat Step 10 for the other gear taper pin, first rotating the gears as necessary to permit drilling and reaming. In each case, make sure cuttings do not get into the gear teeth and remain there.

12. Make a final check of front and back clearances, and spin the impellers to make sure there is no dirt in the casing to cause scraping.

13. Check the end clearances between impellers and headplates. Bump the ends of the shafts as required to make the two ends of each impeller equal clearances.

#### **B—Replacing Shaft Bearings, Seals and Impellers**

Start as in Section A, removing coupling or sheave from the drive shaft. Drain and remove gearhouse, and pull the timing gears. If gears are to be reused, mark them so they may be returned to the same shafts.

1. Remove bearing end cover at the drive end.

2. Make single and double identifying punch marks on the mating edges of headplate and cylinder flanges at the two ends of the blower.

3. At the drive end, drive out the two dowel pins and remove all cap screws holding headplate to cylinder. By inserting jacking screws into the two threaded flange holes, and turning them evenly, the headplate will be separated from the cylinder. As the headplate comes off the shafts it will bring the bearings with it.

4. From the gear end, using a wood or soft metal block against the ends of the shafts, drive them out of the headplate. If they are to be reused, protect them from damage in this operation.

5. If the cylinder is long, or blower interior surfaces need cleaning, it may be advisable to separate the gear end headplate from the cylinder. Use the same general procedure as employed at the drive end.

6. Working from the back (flat) face of each headplate, push or tap out the oil seals and bearings. Use a round bar or tube that will just pass through the shaft clearance holes in the headplates. The seals will be damaged this operation and must be replaced. Note that the 2-1/2, 3-1/2, 4 and 5" blowers employ self-sealed bearings instead of separate seals and open bearings as on the 6" and 7" units.

7. Clean bearing and seal pockets in both headplates, and remove burrs or rough edges on the 6" and 7". Press four new seals into place, using a round tube or bar with recessed end that will bear on the outer metal edge of seal enclosure. Seal lip should point toward the driving tool, and the seal face should be flush with the shoulder in the headplate. Apply a light coat of oil (gear end) or grease (drive end) to the inside surface of the seal lips.

8. Assemble gear end headplate to cylinder checking flange punch marks. Drive in the two locating dowel pins before tightening flange screws.

9. Assemble impellers into the cylinder with the drive shaft (longer shaft) in same location as in original assembly. Before starting the shafts through the headplate holes, make sure shaft ends have no sharp or rough edges to damage seal lips. Position impellers at 90° to each other in the cylinder, using lobe-and-waist match marks if original impellers are being reinstalled.

10. Assemble drive end headplate to cylinder after first removing all sharp edges from shaft shoulders and keyway.

11. 2-1/2", 3-1/2", 4" and 5" units have single sealed bearings on the gear end and drive end in lieu of separate lip seals and open bearings as on the 6" and 7" units. Care must be taken to insure that the bearings are installed with the seals toward the impellers. Install new bearings at gear end. Push bearings onto shafts and press or tap into headplate until approximately 1/8 in. (3 mm) below its machined face. If possible, use a tube with flanged end that will contact both bearing races simultaneously.

Otherwise, work against the inner race and be sure the outer race does not cock as it enters the headplate recess.

12. Install new bearings at drive end. Push bearings onto shafts and press or tap into headplate until approximately "X" inches (mm) below its machined face. (See Figure 6).

13. Install gears and time impellers as in Section A.

14. Set the impeller end clearances equal at both end by tapping on the shaft ends. Install drive end cover (9). Replace drive shaft seal (29) if its lip condition is questionable. Lip must point toward the bearing. Exercise care not to damage the lip as it passes over shaft keyway.

15. Install the gearhouse after cleaning out the inside.

16. Fill with correct grade of oil as specified in "Lubrication" section.

17. Reinstall coupling or belt sheave.

18. Check axial float of the drive shaft and be sure the impeller is not touching either headplate.

#### Internal Clearances

References to operating clearances in this manual include only one mention of the specific amount of clearance to be used or expected. For units in good condition this information is not essential in field service work. Situations may arise, however, when it is desirable to compare existing clearances with the correct Engineering values or to re-establish clearances.

Listed in Table 5 are the range of impeller clearances used in factory assembly of *normal* AF blowers. It should be kept in mind that clearances may change slightly in service, but should never be less than the minimum values listed. Only *well qualified* personnel should attempt to measure clearances for direct comparison with this data.

Table 5 - Normal AF Blower Internal Clearances - Inches (mm)

AF	Impeller Ends	Cylinder	Impeller
Size		Top, Bottom Center	Fronts & Backs
22	.003 -.007 (.08-.18)	.004 -.0055(.10-.14)	.0055-.0075(.14-.19)
24	.003 -.007 (.08-.18)	.004 -.0055(.10-.14)	.0055-.0075(.14-.19)
315	.003 -.007 (.08-.18)	.0045-.0065(.11-.17)	.0085-.0105(.22-.27)
33	.003 -.007 (.08-.18)	.0045-.0065(.11-.17)	.0085-.0105(.22-.27)
36	.003 -.007 (.08-.18)	.0045-.0065(.11-.17)	.0085-.0105(.22-.27)
42	.0035-.0075(.09-.19)	.005 -.007 (.13-.18)	.0095-.0115(.24-.29)
44	.0035-.0075(.09-.19)	.005 -.007 (.13-.18)	.0095-.0115(.24-.29)
47	.0035-.0075(.09-.19)	.005 -.007 (.13-.18)	.0095-.0115(.24-.29)
53	.0035-.0075(.09-.19)	.0055-.0075(.14-.19)	.0115-.0135(.29-.34)
55	.0035-.0075(.09-.19)	.0055-.0075(.14-.19)	.0115-.0135(.29-.34)
59	.0035-.0075(.09-.19)	.0055-.0075(.14-.19)	.0115-.0135(.29-.34)
65	.007 -.011 (.18-.28)	.0065-.0085(.17-.22)	.011 -.013 (.28-.33)
67	.007 -.011 (.18-.28)	.0065-.0085(.17-.22)	.011 -.013 (.28-.33)
610	.007 -.011 (.18-.28)	.0065-.0085(.17-.22)	.011 -.013 (.28-.33)
615	.007 -.011 (.18-.28)	.0065-.0085(.17-.22)	.011 -.013 (.28-.33)
76	.008 -.012 (.20-.30)	.0075-.0095(.19-.24)	.013 -.015 (.33-.38)
710	.008 -.012 (.20-.30)	.0075-.0095(.19-.24)	.013 -.015 (.33-.38)
717	.008 -.012 (.20-.30)	.0075-.0095(.19-.24)	.013 -.015 (.33-.38)

Table 6 - Parts Identification List for Figure 6

Item No.	Quantity Used	Identification
1	1	G. E. Head
2	1	D. E. Head
3	1	Cylinder
4	1	Drive Shaft & Impeller Assembly
5	1	Driven Shaft & Impeller Assembly
6	2	Gear
7	1	Gearhouse
8	1	Gasket
9	1	Blind Cover
11	1	Nameplate
12	1	Lube Label
13	2	Bearing, Drive End
14	4	Dowel Pin
15	2	Tin Plug
16	2	Taper Pin (Gear)
17	Varies	Capscrew (Hd. to Cyl.)
18	Varies	Capscrew (Gearhouse to Hd.)
20	2	Drive Screw
21	2	Grease Fitting
22	2	Pressure Relief Fitting
23	1	Oil Drain Plug
25	1	Oil Level Plug
26	1	Breather & Oil Fill Plug
28	1	Key
29	1	End Cover Seal
30	2	Headplate Seal 6" & 7" Only
31	2	Bearing, Gear End
32	4	Capscrew (Hd. to Cyl.) used on 22, 24, 315, 42 only

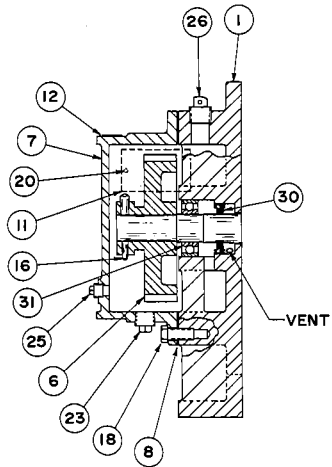

**GEAR END ASSEMBLY**  
6" & 7" FRAME SIZES

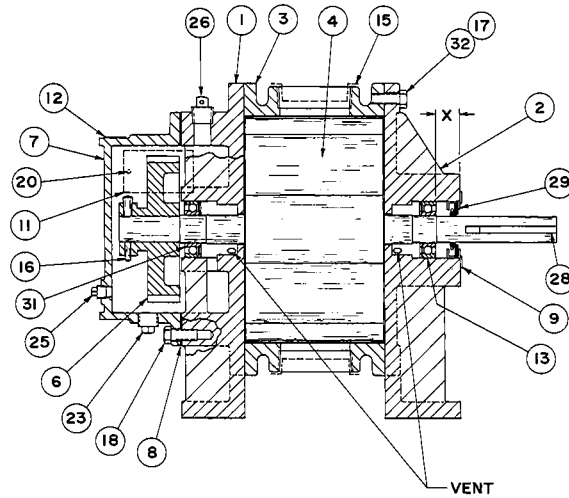

**DRIVE END ASSEMBLY**  
6" & 7" FRAME SIZES

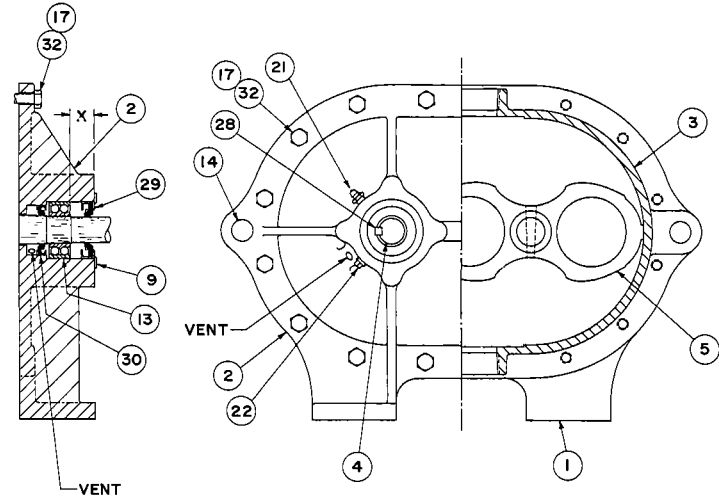

**ASSEMBLY NOTES**

1. ALL SIZES - GEAR HUBS TO BE INSTALLED FLUSH WITH END OF SHAFT.
2. ALL SIZES - DRIVE END BEARINGS TO BE INSTALLED APPROX. "X" DEEP IN HEADPLATE BORE - SEE TABLE AT RIGHT.
3. ALL SIZES - GEAR END BEARINGS TO BE INSTALLED APPROX. 1/8" DEEP IN HEADPLATE BORE.(3mm)
4. 2 1/2" THRU 5" SIZES - BEARINGS TO BE INSTALLED WITH SEALS TOWARD IMPELLERS.
5. 6" AND 7" SIZES - HEADPLATE SEALS TO BE INSTALLED FLUSH WITH FRONT EDGE OF MACHINED BORE.  
VENT HOLES MUST NOT BE BLOCKED.
6. ALL SIZES - DRIVE SHAFT SEAL TO BE INSTALLED FLUSH WITH HEADPLATE FACE.

SIZE	"X"	
2 1/2"	9/16"	(14 mm)
3 1/2"	9/16"	(14 mm)
4"	5/8"	(16 mm)
5"	1 1/16"	(18 mm)
6"	1 1/16"	(18 mm)
7"	1 1/16"	(18 mm)

ALL DIMENSIONS SHOWN IN PARENTHESIS ( )  
ARE MILLIMETERS

Figure 6 - Assembly of AF Blowers