

Stoddard Silencers, Inc.
 1017 Progress Dr.
 Grayslake, Illinois 60030
 Phone (847) 223-8636

name

F65V-4 Inline Filter with
 F8-109 Filter Element

A

no. 45V005

date 4/25/05

by JJB

appd.

no.	
revision	
date	
by	
no.	1
date	
by	
A	
no.	45V005
rev.	-0

VACUUM USE ONLY

Quick Access
 (4) A40-122 Clips

8 Holes 3/4" Dia on
 7-1/2" Bolt Circle
 Straddling Centerlines
 Both Flanges

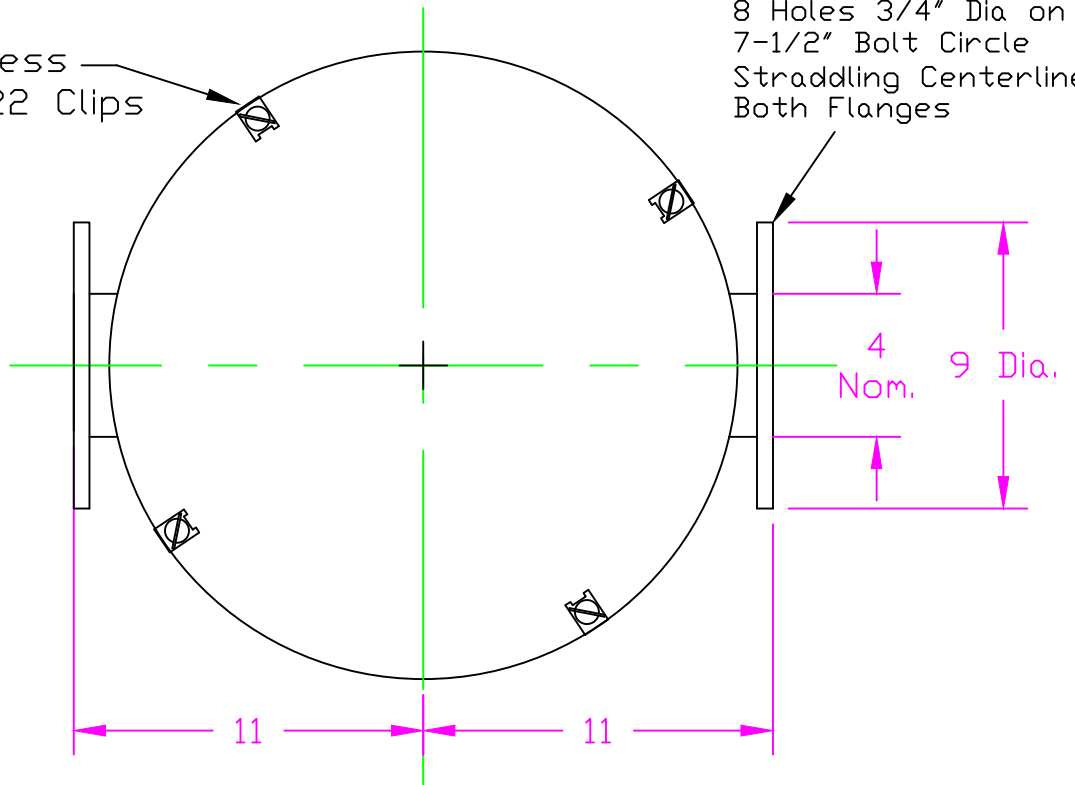

Access panel for
 Filter Removal

F8-109 Replaceable
 Filter Element

(2) 1/4" Half
 Coupling and Plug

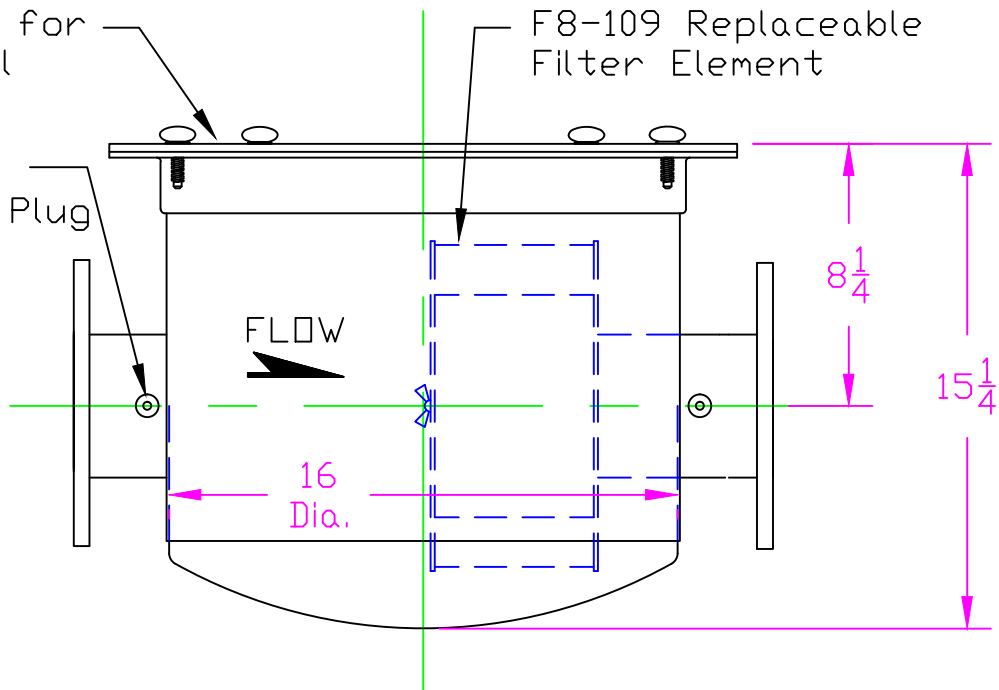

EXTERNAL DIMENSIONS CERTIFIED FOR:

CUST.
 P.O. No.

S.S. NO.
 BY

approx. wt.	65	lbs.
material	Carbon Steel	
finish	Shop Coat Primer	