

FRAME	APPROX. OIL CAPACITY
3-1/2	16.0 FL. OZ.
4	22.8 FL. OZ.

FRAME SIZE	AG	AH	AJ	AK	AL
36	1.50	1.94	2.00	2.75	2.38
45	1.50	1.94	2.06	2.50	2.38
47	1.50	1.94	2.44	3.38	3.00

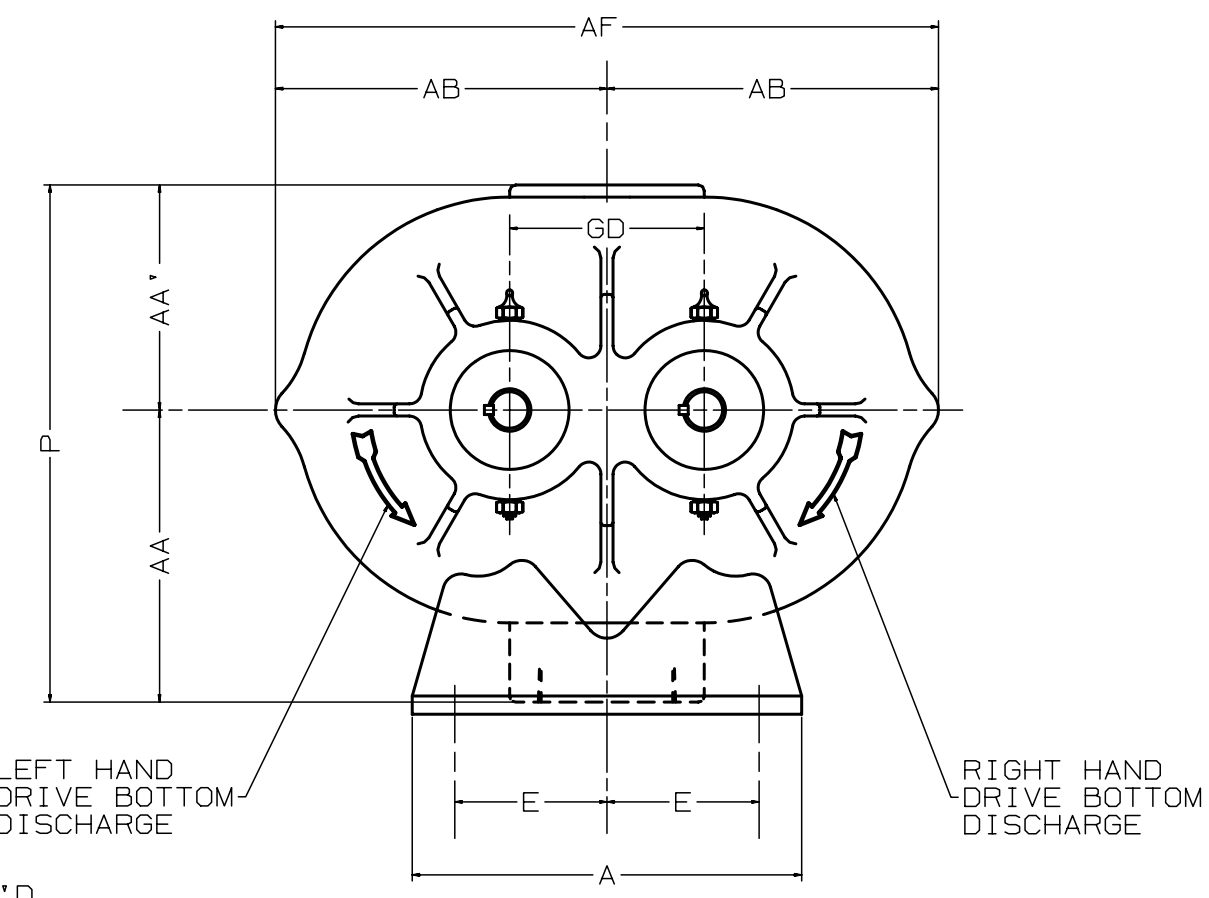
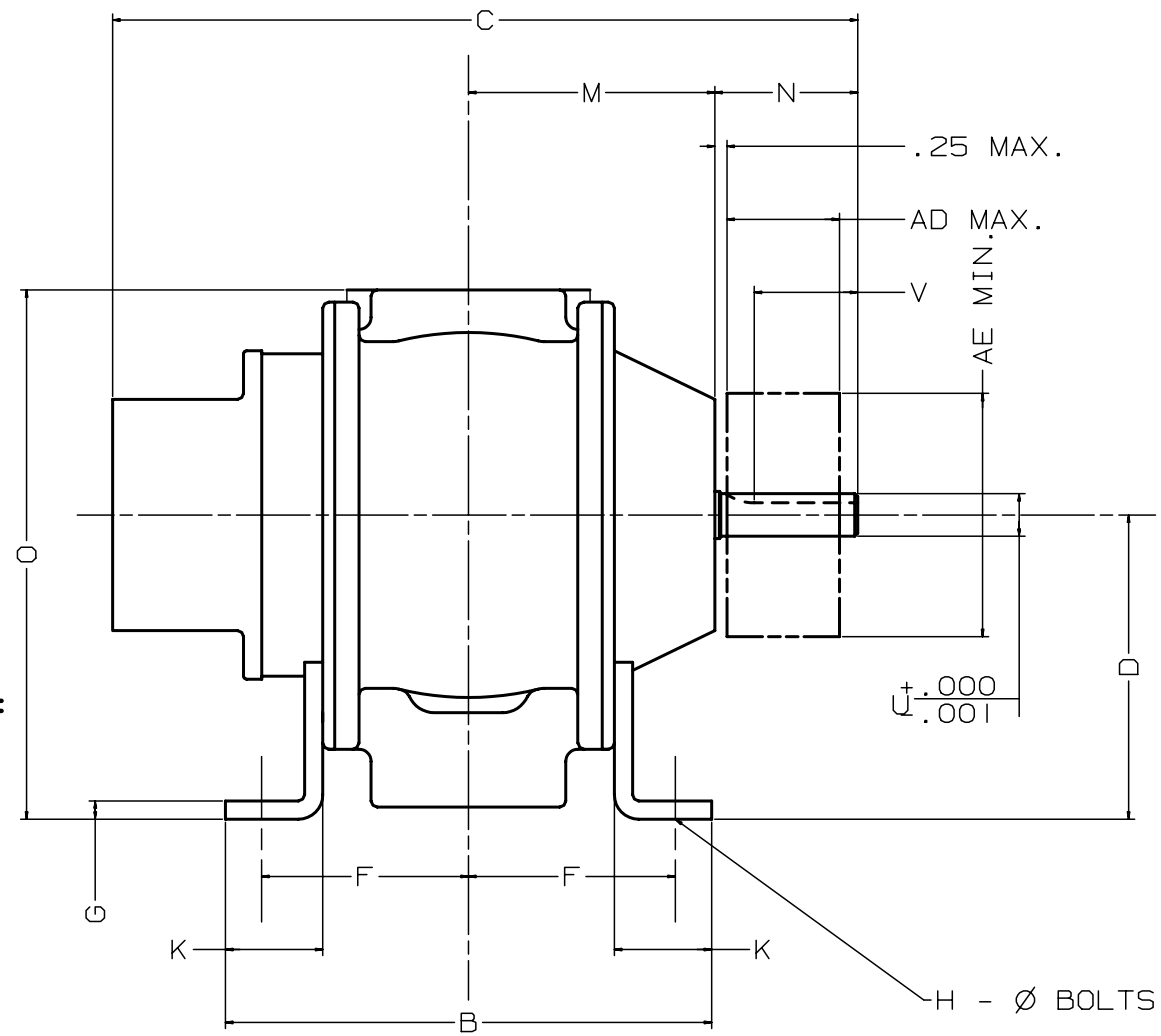
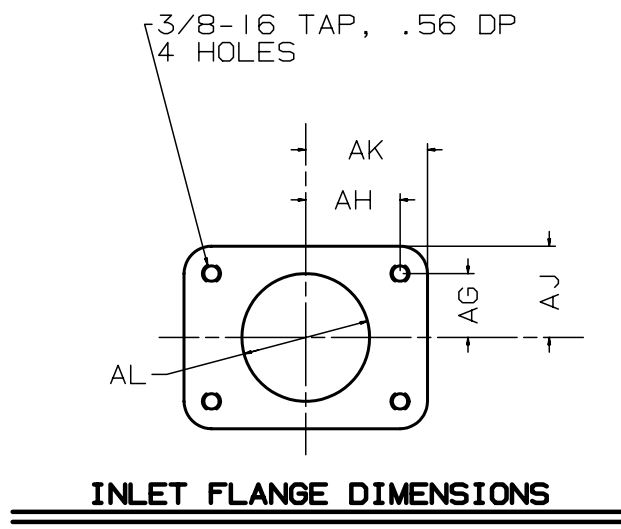

W - DISCHARGE
 AD - SHEAVE WIDTH
 AE - SHEAVE DIAMETER

**UNIVERSAL RAI-J BLOWER (HYDRAMASTER)
 w/DUAL DRIVE SHAFT**

ALL DIMENSIONS IN INCHES

FRAME SIZE	GD	A	B	C	D	E MIN.	E MAX.	F MIN.	F MAX.	G	H	K	M	N	O	P	U	KEYWAY	W NPT.	V	AA	AA'	AB	AD	AE	AF	APPROX. WT. LBS
36	3.50	7.25	10.00	14.63	5.00	2.50	2.88	4.18	4.44	.25	.44	1.75	5.00	2.56	9.13	9.63	.750	.188x.094	2-1/2"	1.75	5.50	4.13	6.06	1.91	5.00	12.13	110
45	4.00	8.00	10.00	15.50	6.25	3.00	3.13	3.56	4.25	.31	.44	2.00	5.06	2.94	10.88	10.63	.875	.188x.094	2-1/2"	2.13	6.00	4.63	6.81	2.31	5.00	13.63	113
47	4.00	8.00	11.75	17.63	6.25	3.00	3.13	4.63	5.38	.31	.44	2.00	5.94	3.31	10.88	10.63	.875	.188x.094	3"	2.50	6.00	4.63	6.81	2.31	5.00	13.63	136