

DWG. NO.  
54134.W

ITEM	PART	DESCRIPTION	QTY.
A	54134	SLIDE BASE, MOTOR, 405T FRAME, DBL. ADJ.	1
B	30497	NUT, 3/4"-10, WELD, SQUARE, PLAIN	2
C	30247.A	BOLT, 3/4"-10 x 6", #5, ZINC, SET SCREW, SQUARE HEAD	2

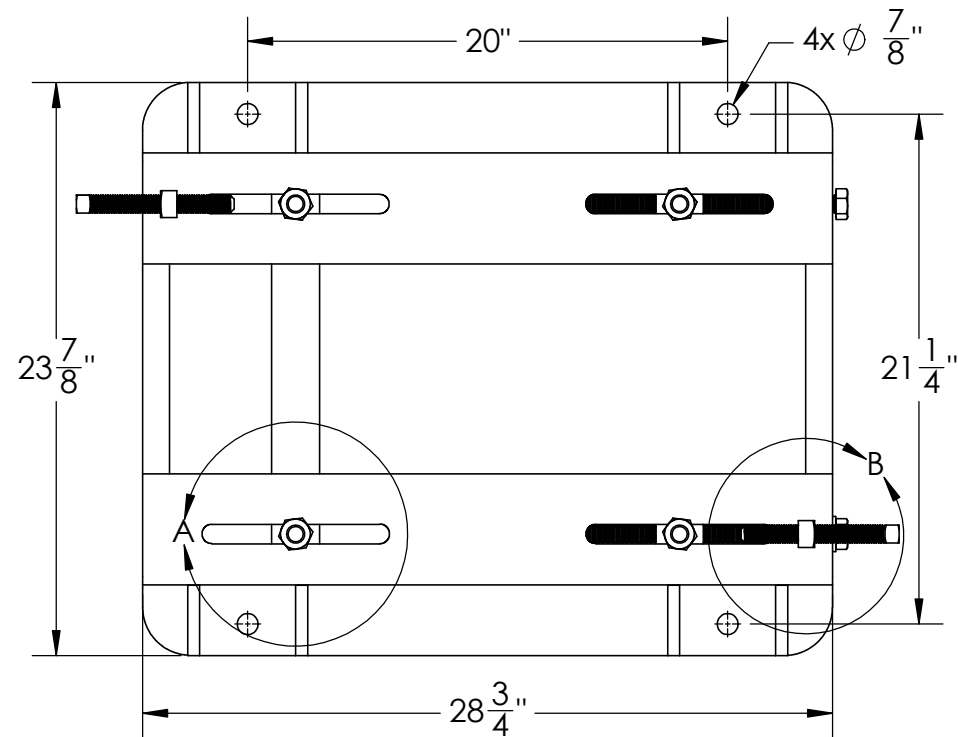

**TOP VIEW**

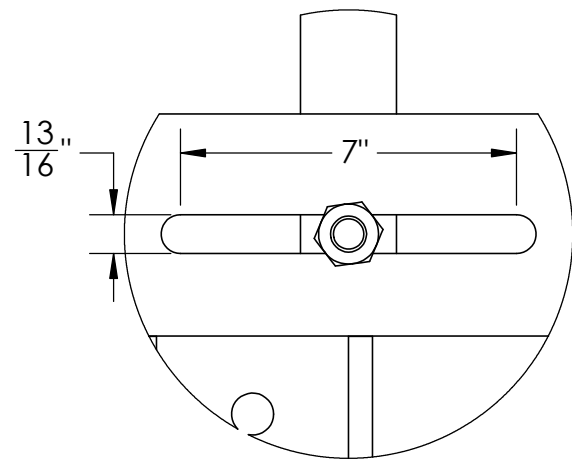

DETAIL A  
BOLT SLOTS (4x TYP)  
SCALE 1 : 4

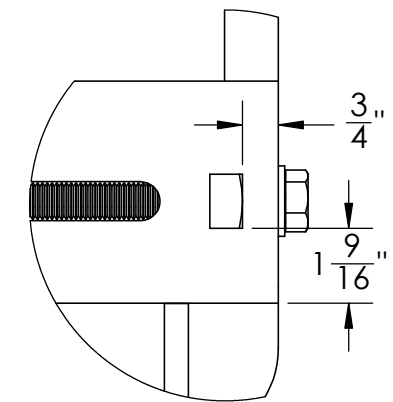

DETAIL B  
WELD NUT (4x TYP)  
SCALE 1 : 4

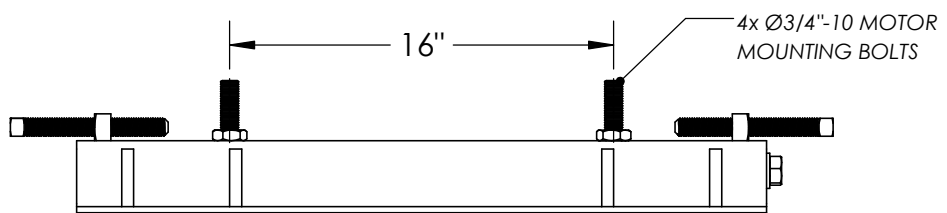
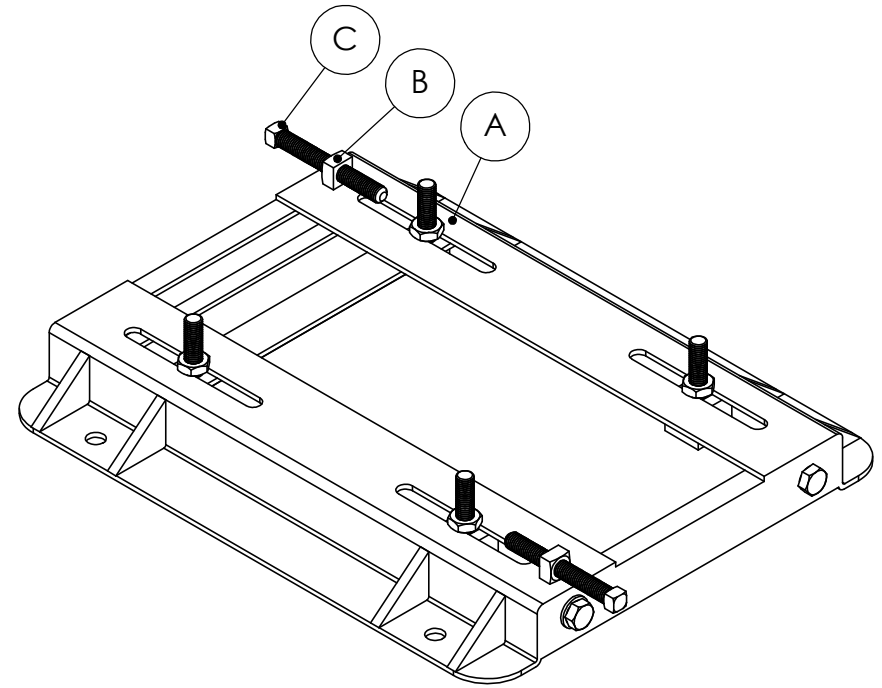

**FRONT VIEW**

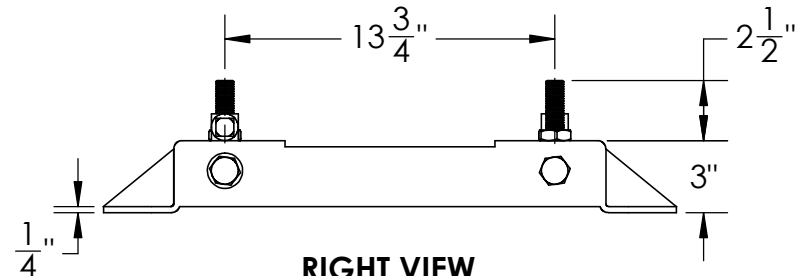

**RIGHT VIEW**

UNLESS OTHERWISE SPECIFIED:		DRAWN	DATE	NAME	 2280 Chicopee Mill Road SW • Gainesville, GA • 30504 800-534-9933
DIMENSIONS ARE IN INCHES		AUTHOR	6/5/2018	JDM	
TOLERANCES:		CHECKED BY			
FRACTIONAL ±		MFG APPR.			
ANGULAR: MACH ± BEND ±		COMMENTS:			TITLE: BASE, MOTOR 405T FRAME PUSHING BOLTS
TWO PLACE DECIMAL ±					SIZE DWG. NO. REV
THREE PLACE DECIMAL ±					<b>B</b> 54134.W
INTERPRET GEOMETRIC TOLERANCING PER:					SCALE: 1:8 SHEET 1 OF 1
MATERIAL SEE BOM					
THICKNESS: SEE BOM					
FINISH					
WEIGHT:					
PROPRIETARY AND CONFIDENTIAL THE INFORMATION CONTAINED IN THIS DRAWING IS THE SOLE PROPERTY OF PDBLOWERS, INC. ANY REPRODUCTION IN PART OR AS A WHOLE WITHOUT THE WRITTEN PERMISSION OF PDBLOWERS, INC IS PROHIBITED.					