

DWG. NO.
54140.W

ITEM	PART	DESCRIPTION	QTY.
A	54140	SLIDE BASE, MOTOR, 445T FRAME, DBL. ADJ.	1
B	30497	NUT, 3/4"-10, WELD, SQUARE, PLAIN	2
C	30247.A	BOLT, 3/4"-10 x 6", #5, ZINC, SET SCREW, SQUARE HEAD	2

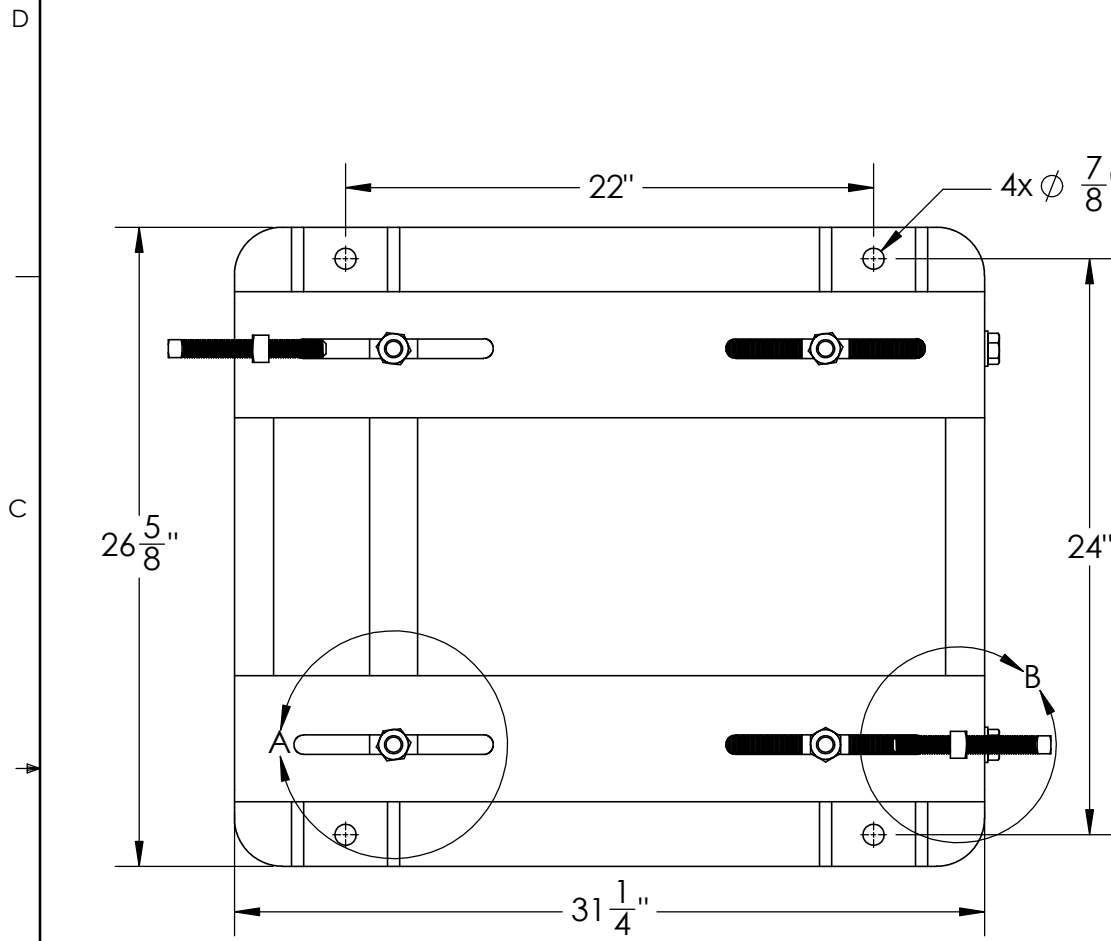

TOP VIEW

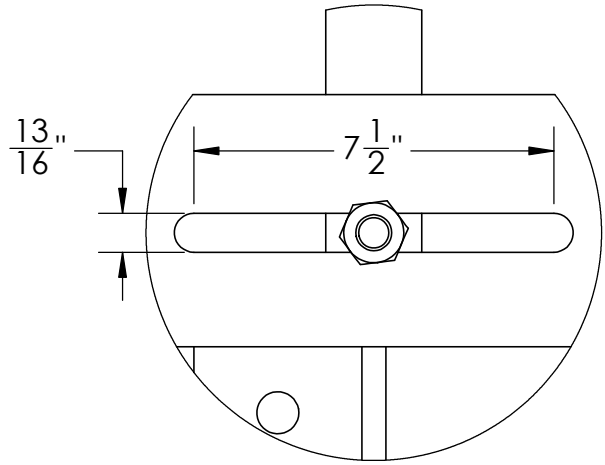

DETAIL A
BOLT SLOTS (4x TYP)
SCALE 1 : 4

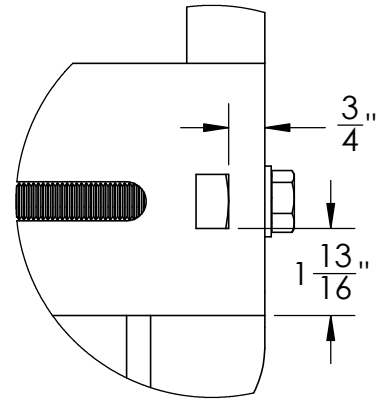

DETAIL B
WELD NUT (4x TYP)
SCALE 1 : 4

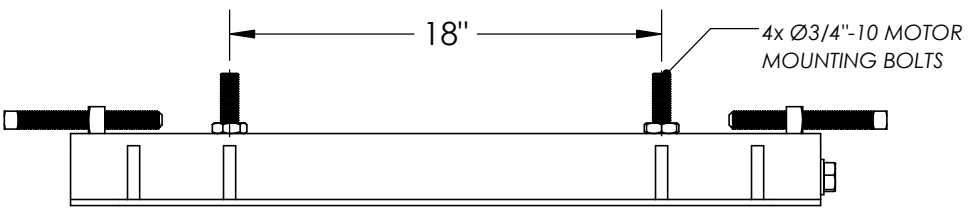
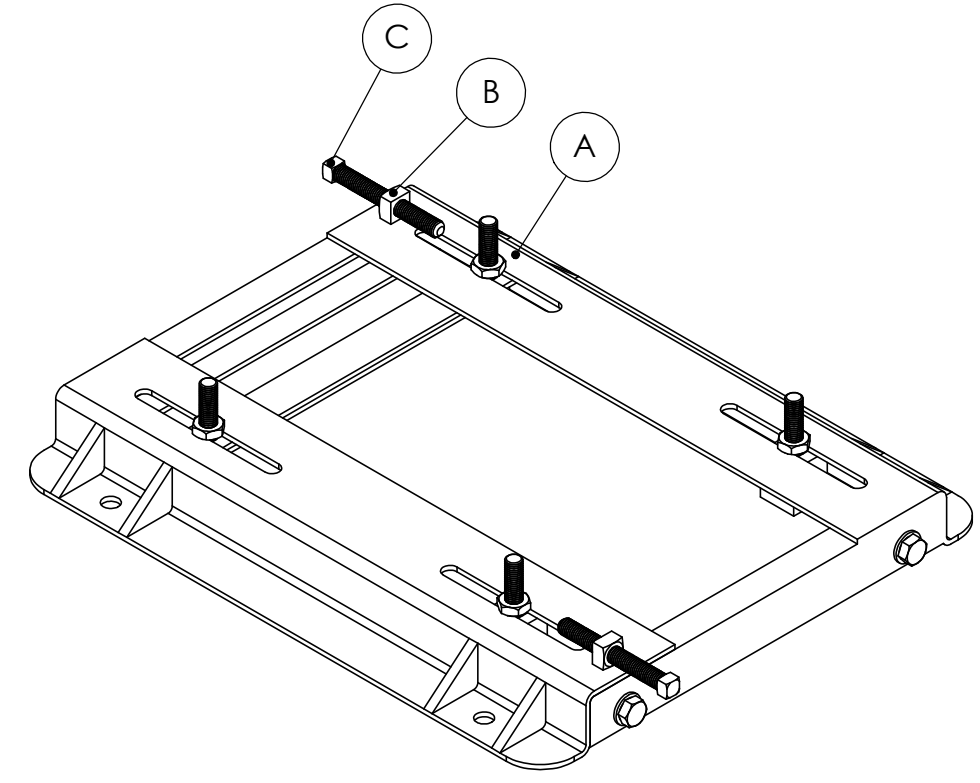

FRONT VIEW

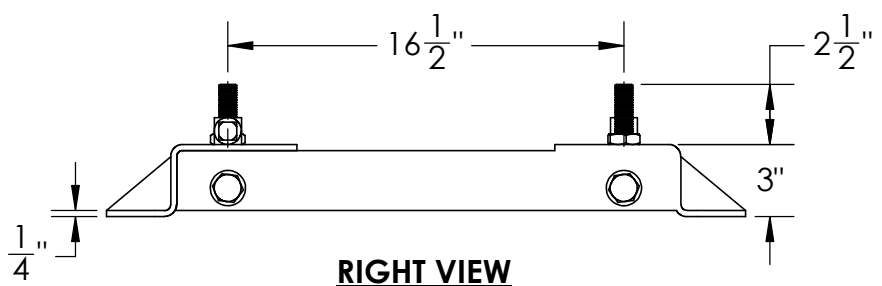

RIGHT VIEW

UNLESS OTHERWISE SPECIFIED:		DRAWN	DATE	NAME	 2280 Chicopee Mill Road SW • Gainesville, GA • 30504 800-534-9933
DIMENSIONS ARE IN INCHES		AUTHOR	6/5/2018	JDM	
TOLERANCES:		CHECKED BY			
FRACTIONAL ±		MFG APPR.			
ANGULAR: MACH ± BEND ±		COMMENTS:			TITLE: BASE, MOTOR 445T FRAME PUSHING BOLTS
TWO PLACE DECIMAL ±					SIZE DWG. NO. REV
THREE PLACE DECIMAL ±					B 54140.W
INTERPRET GEOMETRIC TOLERANCING PER:					SCALE: 1:8 SHEET 1 OF 1
MATERIAL SEE BOM					
THICKNESS: SEE BOM					
FINISH					
WEIGHT:					
PROPRIETARY AND CONFIDENTIAL THE INFORMATION CONTAINED IN THIS DRAWING IS THE SOLE PROPERTY OF PDBLOWERS, INC. ANY REPRODUCTION IN PART OR AS A WHOLE WITHOUT THE WRITTEN PERMISSION OF PDBLOWERS, INC IS PROHIBITED.					