

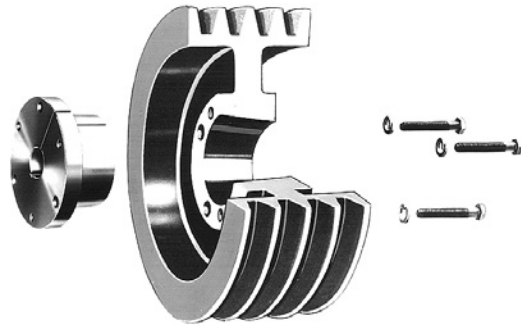

FEATURES/BENEFITS

QD Bushings



- 4 Degree Taper
- Easy on/Easy off
- Manufactured precisely to industry standards
- Conventional or Reverse Mounting, Including sizes M thru W - DODGE exclusive!
- QD is a registered trademark of Emerson Electric.

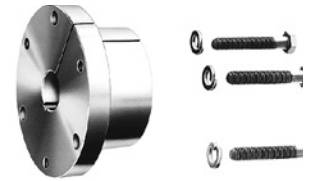

CONVENTIONAL

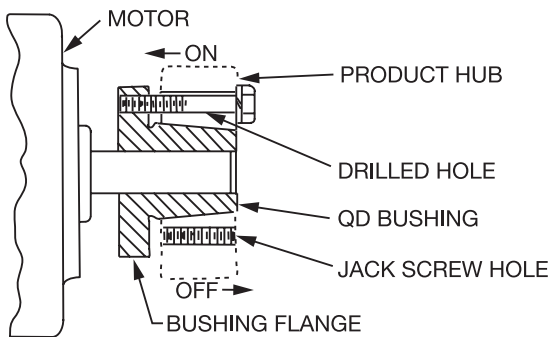

REVERSE

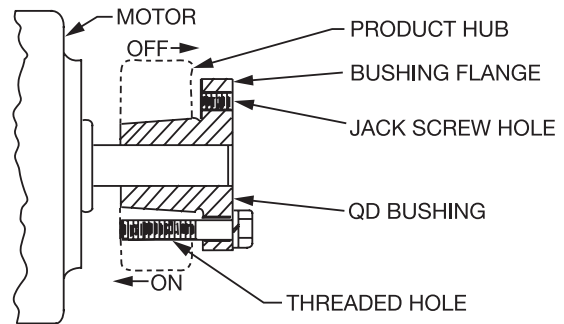

Conventional Mounting

Easy On

- Place bushing in product
- Align clearance holes in product with threaded holes in bushing
- Install screws and lockwashers thru clearance holes, finger tight
- Slide assembly onto shaft, flange first
- Locate assembly on shaft for proper drive alignment
- Tighten cap screws alternately and evenly to specified torque

Easy Off

- Remove cap screws and install in product threaded holes
- Alternately and evenly tighten screws until bushing grip is released
- Flanged Design

Reverse Mounting

Easy On

- Place bushing in product
- Align clearance holes in product with threaded holes in bushing
- Install screws and lockwashers thru clearance holes, finger tight
- Slide assembly onto shaft, flange outward
- Locate assembly on shaft for proper drive alignment
- Tighten cap screws alternately and evenly to specified torque

Easy Off

- Remove cap screws and reinstall in flange threaded holes
- Alternately and evenly tighten screws until bushing grip is released

IMPORTANT! Do not use lubricants or anti-seize compounds on tapered bore or bushing surfaces. Complete installation instructions are available at www.dodge-pt.com.



SPECIFICATION

QD Bushings - Dimensions

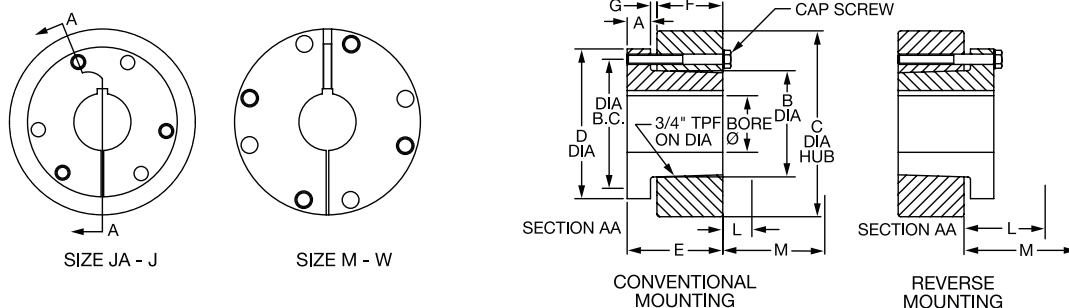

QD Bushing Ratings And Dimensions

Bush. Symb.	Ratings (Lb-in) Bush. Torque Cap.*	Bore Range				Dimensions							
		Min.	Max. Bore for:			A	B Dia.	C Hub Dia.		D Dia.	E	F	G
			Full KW	Shallow KW	No KW			CI 30 Iron	Steel				
QT / (L)	1000	3/8	1-1/4	1-1/2	1-9/16	0.35	1.63	3.00	2.375	2.50	1.35	0.94	0.12
JA	1000	1/2	1	1-3/16	1-1/4	0.31	1.38	3.93	2.25	2.00	1.00	0.56	0.12
SH	3500	1/2	1-3/8	1-5/8	1-11/16	0.38	1.88	4.75	3.00	2.63	1.25	0.81	0.12
SDS	5000	1/2	1-5/8	1-15/16	2	0.43	2.18	4.75	3.50	3.18	1.31	0.75	0.12
SD	5000	1/2	1-5/8	1-15/16	2	0.43	2.18	3.81	3.50	3.18	1.81	1.25	0.12
SK	7000	1/2	2-1/8	2-1/2	2-5/8	0.50	2.81	4.75	4.50	3.88	1.88	1.25	0.22
SF	11000	1/2	2-5/16	2-15/16	...	0.50	3.13	6.38	5.50	4.63	2.00	1.25	0.22
E	20000	7/8	2-7/8	3-1/2	...	0.75	3.83	7.50	6.50	6.00	2.63	1.63	0.25
F	30000	1	3-1/4	3-15/16	4	0.81	4.43	7.75	7.25	6.63	3.63	2.50	0.34
J	45000	1-1/2	3-3/4	4-1/2	...	1.00	5.14	9.00	8.00	7.25	4.50	3.18	0.38
M	85000	2	4-3/4	5-1/2	...	1.25	6.50	11.38	10.00	9.00	6.75	5.18	0.41
N	150000	2-7/16	5	6	...	1.50	7.00	12.00	...	10.00	8.12	6.25	0.56
P	250000	2-15/16	5-15/16	7	...	1.75	8.25	14.00	...	11.75	9.38	7.25	0.63
W	375000	4	7-1/2	8-1/2	...	2.00	10.42	17.00	...	15.00	11.38	9.00	0.50
S	625000	5-1/2	9	10	...	3.25	12.13	19.00	...	17.75	15.75	12.00	0.75

* Torque ratings apply when bushing installation screws are tightened to listed torque. Important: Do not over-torque screws. This can lead to hub damage

Installation Information

Bush. Sym.	Installation Screws				Required Wrench Clearance							
	B. C. Dia.	Qty.	Size	Screw Torque (Lb - in)	Conventional Mounting				Reverse Mounting			
					L-Install		M-Remove		L-Install		M-Remove	
					#	@	#	@	#	@	#	@
QT / (L)	2	2	1/4-20 x 7/8	90	0.41	2.53	1.13	3.25	1.13	3.25	1.56	3.68
JA	1.65	3	10-24 x 1	60	0.41	2.53	1.13	3.25	1.13	3.25	1.56	3.68
SH	2.25	3	1/4-20x 1-3/8	108	0.54	2.61	1.51	3.58	1.51	3.58	2.08	4.13
SDS	2.69	3	1/4-20 x 1-3/8	108	0.59	2.66	1.56	3.63	1.56	3.63	2.13	4.18
SD	2.69	3	1/4-20 x 1-7/8	108	0.66	2.72	2.06	4.13	2.06	4.13	2.63	4.68
SK	3.31	3	5/16-18 x 2	180	0.72	2.66	2.19	4.19	2.25	4.25	2.32	4.94
SF	3.88	3	3/8-16 x 2	360	0.78	2.78	2.25	4.23	2.30	4.30	3.19	5.18
E	5.00	3	1/2 -13 x 2-3/4	720	1.12	3.06	3.00	4.93	3.05	5.00	4.30	6.25
F	5.63	3	9/16-12 x 3-5/8	900	1.09	2.91	3.94	5.75	3.99	5.81	5.31	7.12
J	6.25	3	5/8-11 x 4-1/2	1620	1.28	3.09	4.81	6.62	3.80	5.62	5.37	7.18
M	7.88	4	3/4-10 x 6-3/4	2700	2.16	4.03	7.69	9.56
N	8.50	4	7/8-9 x 8	3600	2.28	...	9.25
P	10.00	4	1-8 x 9-1/2	5400	3.13	...	10.88
W	12.75	4	1-1/8-7 x 11-1/2	7200	3.88	...	13.38
S	15.00	5	1-1/4 -7x 15	9000	3.75	...	16.50

Using Open-End Wrench

@ Using Socket Wrench

NOTE: Installation and maintenance instructions for Dodge products available at www.dodge-pt.com

T-L FEATURES/BENEFITS PAGE PT6-2	T-L SPECIFICATION PAGE PT6-3	QD BUSHINGS PAGE PT6-16	GT BUSHINGS PAGE PT6-28
-------------------------------------	---------------------------------	----------------------------	----------------------------



SPECIFICATION

Bushings For Bushed FHP Sheave - Stock Bore

QD Bush Size	BORE	P/N Keyway	WT.	Bushing Keyway	Shaft Keyway REF	Key Size REF
QT / (L)	3/8"	121129	0.85	None		
	7/16"	121130	0.82			
	1/2"	121131	0.81	1/8 x 1/16	1/8 x 1/16	1/8 x 1/8
	9/16"	121133	0.80			
	5/8"	122050	0.78	3/16 x 3/32	3/16 x 3/32	3/16 x 3/16
	11/16"	121134	0.76			
	3/4"	121162 +	0.74			
	3/4"	122051	0.74			
	13/16"	121136	0.70			
	7/8"	121163 +	0.68			
	7/8"	122052	0.68			
	15/16"	121138	0.66	1/4 x 1/8	1/4 x 1/8	1/4 x 1/4
	1"	121164 +	0.62			
	1"	122053	0.62			
	1-1/16"	121140	0.59			
	1-1/8"	121186 +	0.56			
	1-1/8"	122054	0.56			
	1-3/16"	121187 +	0.52			
	1-3/16"	122055	0.52			
	1-1/4"	122056	0.49			
1-5/16"	121144	0.44	5/16 x 1/16			
1-3/8"	121145	0.43				
1-7/16"	121146	0.38	3/8 x 1/16	3/8 x 3/16	3/8 x 1/4 *	
1-1/2"	121147	0.34				
14MM	121148	0.79	5 x 2.3MM	5 x 3MM	5 x 5MM	
19MM	121149	0.74	6 x 2.8MM	6 x 3.5MM	6 x 6MM	
20MM	121467	0.73				
25MM	121151	0.63	8 X 3.3MM	8 X 4MM	8 X 7MM	
28MM	151152	0.57				
30MM	121153	0.53				
32MM	121154	0.50				10 x 3.3MM

QD Bushings - Stock Bore

QD Bush Size	Bore	P/N	WT.	Bushing Keyway	Shaft Keyway REF	Key Size REF	
JA	1/2"	120332	0.46	1/8 x 1/16	1/8 x 1/16	1/8 x 1/8	
	9/16"	120333	0.46				
	5/8"	120334	0.45	3/16 x 3/32	3/16 x 3/32	3/16 x 3/16	
	11/16"	120335	0.43				
	3/4"	120336	0.41				
	13/16"	120337	0.40				
	7/8"	120338	0.37				
	15/16"	120339	0.35	1/4 x 1/8	1/4 x 1/8	1/4 x 1/4	
	1"	120340	0.33				
	1-1/16"	120341	0.34	1/4 x 1/16	1/4 x 1/8	1/4 x 3/16 *	
	1-1/8"	120342	0.31				
	1-3/16"	120343	0.29				
	1-1/4"	120344	0.25	None			
	19MM	117049	0.42	6 x 2.8MM	6 x 3.5MM	6 x 6MM	
	20MM	120329	0.41				
	22MM	117043	0.40				
	SH	1/2"	120345	1.16	1/8 x 1/16	1/8 x 1/16	1/8 x 1/8
		9/16"	120346	1.14			
		5/8"	120347	1.14	3/16 x 3/32	3/16 x 3/32	3/16 x 3/16
		11/16"	120348	1.14			
3/4"		120349	1.10				
13/16"		120350	1.07				
7/8"		120351	1.04				
15/16"		120352	1.00	1/4 x 1/8	1/4 x 1/8	1/4 x 1/4	
1"		120353	0.98				
1-1/16"		120354	0.94				
1-1/8"		120355	0.91				
1-3/16"		120356	0.88				
1-1/4"		120357	0.84				
1-5/16"		120358	0.82	5/16 x 5/32	5/16 x 5/32	5/16 x 5/16	
1-3/8"		120359	0.80				
1-7/16"		120360	0.79	3/8 x 1/16	3/8 x 3/16	3/8 x 1/4 *	
1-1/2"		120361	0.75				
1-9/16"		120362	0.90				
1-5/8"		120363	0.64				
1-11/16"		120580	0.55	None			
24MM	120088	1.00	8 X 3.3MM	8 X 4MM	8 X 7MM		
25MM	120089	0.99					
28MM	120090	0.93					
30MM	120091	0.87					
32MM	120092	0.82	10 X 3.3MM	10 X 5MM	10 X 8MM		
35MM	120093	0.74					
SDS	1/2"	120388	1.65	1/8 x 1/16	1/8 x 1/16	1/8 x 1/8	
	9/16"	120389	1.65				
	5/8"	120390	1.61	3/16 x 3/32	3/16 x 3/32	3/16 x 3/16	
	11/16"	120391	1.60				
	3/4"	120392	1.58				
	13/16"	120393	1.54				
	7/8"	120394	1.54				
	15/16"	120395	1.50	1/4 x 1/8	1/4 x 1/8	1/4 x 1/4	
	1"	120396	1.46				
	1-1/16"	120397	1.43				
	1-1/8"	120398	1.38				
	1-3/16"	120399	1.36				
	1-1/4"	120400	1.32				
	1-5/16"	120401	1.26	5/16 x 5/32	5/16 x 5/32	5/16 x 5/16	
1-3/8"	120402	1.24					

P/N's marked (+) are Integral Key Bushings

Bore sizes marked (#) will be supplied with 1/2" wide keyway unless the 5/8" wide keyway is specified when ordering

* Key furnished for these sizes ONLY

** Key not furnished for MM bores sizes



SPECIFICATION

QD Bushings - Stock Bore

QD Bush Size	Bore	P/N	WT.	Bushing Keyway	Shaft Keyway REF	Key Size REF
SDS (cont)	1-7/16"	120403	1.19			
	1-1/2"	120404	1.15	3/8 x 3/16	3/8 x 3/16	3/8 x 3/8
	1-9/16"	120405	1.11			
	1-5/8"	120406	1.08			
	1-11/16"	120407	1.08	3/8 x 1/8	3/8 x 3/16	3/8 x 5/16 *
	1-3/4"	120408	1.02			
	1-13/16"	120409	0.98	1/2 x 1/16	1/2 x 1/4	1/2 x 5/16 *
	1-7/8"	120410	0.92			
	1-15/16"	120411	0.87			
	2"	120412	0.77	None		
	24MM	120094	1.47	8 X 3.3MM	8 X 4MM	8 X 7MM
	25MM	120095	1.47			
	28MM	120096	1.41			
	30MM	120097	1.36			
	32MM	120098	1.31	10 X 3.3MM	10 X 5MM	10 X 8MM
	35MM	120099	1.22			
	38MM	120100	1.00			
	40MM	120101	1.01	12 X 3.3MM	12 X 5MM	12 X 8MM
42MM	120102	1.02				
SD	1/2"	120364	2.07	1/8 x 1/16	1/8 x 1/16	1/8 x 1/8
	9/16"	120365	2.05			
	5/8"	120366	2.03	3/16 x 3/32	3/16 x 3/32	3/16 x 3/16
	11/16"	120367	2.00			
	3/4"	120368	2.00			
	13/16"	120369	2.00			
	7/8"	120370	1.88			
	15/16"	120371	1.85	1/4 x 1/8	1/4 x 1/8	1/4 x 1/4
	1"	120372	1.80			
	1-1/16"	120373	1.79			
	1-1/8"	120374	1.72			
	1-3/16"	120375	1.67			
	1-1/4"	120376	1.62			
	1-5/16"	120377	1.55	5/16 x 5/32	5/16 x 5/32	5/16 x 5/16
	1-3/8"	120378	1.50			
	1-7/16"	120379	1.44	3/8 x 3/16	3/8 x 3/16	3/8 x 3/8
	1-1/2"	120380	1.36			
	1-9/16"	120381	1.29			
	1-5/8"	120382	1.29			
	1-11/16"	120383	1.20			
	1-3/4"	120384	1.19			
	1-13/16"	120385	1.15			
	1-7/8"	120386	1.07			
	1-15/16"	120387	1.00			
	2"	120581	0.84			
	24MM	120103	1.84	8 X 3.3MM	8 X 4MM	8 X 7MM
	25MM	120104	1.82			
	28MM	120105	1.72			
	30MM	120106	1.66			
	32MM	120107	1.58			
35MM	120108	1.49	10 X 3.3MM	10 X 5MM	10 X 8MM	
38MM	120109	1.37				
40MM	120110	1.28	12 X 3.3MM	12 X 5MM	12 X 8MM	
42MM	120111	1.18				
SK	1/2"	120413	3.77	1/8 x 1/16	1/8 x 1/16	1/8 x 1/8
	9/16"	120414	3.74			
	5/8"	120415	3.72	3/16 x 3/32	3/16 x 3/32	3/16 x 3/16
	11/16"	120416	3.70			
	3/4"	120417	3.61			
	13/16"	120418	3.53			
	7/8"	120419	3.58			
	15/16"	120420	3.52	1/4 x 1/8	1/4 x 1/8	1/4 x 1/4
	1"	120421	3.45			
	1-1/16"	120422	3.41			
	1-1/8"	120423	3.37			
	1-3/16"	120424	3.31			
	1-1/4"	120425	3.31			
	1-5/16"	120426	3.18			
	1-3/8"	120427	3.12			
	1-7/16"	120428	3.08			
	1-1/2"	120429	3.00			
	1-9/16"	120430	2.95	3/8 x 3/16	3/8 x 3/16	3/8 x 3/8
	1-5/8"	120431	2.86			
	1-11/16"	120432	2.79			
	1-3/4"	120433	2.88			
	1-13/16"	120434	2.62			
	1-7/8"	120435	2.50	1/2 x 1/4	1/2 x 1/4	1/2 x 1/2
	1-15/16"	120436	2.42			
	2"	120437	2.32			
	2-1/16"	120438	2.26			
	2-1/8"	120439	2.17			
	2-3/16"	120440	2.21			
	2-1/4"	120441	2.09			
	2-5/16"	120442	2.00			
	2-3/8"	120443	1.91			
	2-7/16"	120444	1.81			
	2-1/2"	120445	1.72			
2-5/8"	120447	1.32	None			
24MM	120112	3.52	8 X 3.3MM	8 X 4MM	8 X 7MM	
25MM	120113	3.50				
28MM	120114	3.41				
30MM	120115	3.31				
32MM	120116	3.31				
35MM	120117	3.12	10 X 3.3MM	10 X 5MM	10 X 8MM	
38MM	120118	2.98				
40MM	120119	2.95				
42MM	120120	2.86	12 X 3.3MM	12 X 5MM	12 X 8MM	
45MM	120070	2.69				
48MM	120121	2.50	14 X 3.8MM	14 X 5.5MM	14 X 9MM	
50MM	120122	2.40				
55MM	120123	2.17				
16 X 4.3MM	120123	2.17	16 X 4.3MM	16 X 6MM	16 X 10MM	
SF	1/2"	120448	5.27	1/8 x 1/4	1/8 x 1/4	1/8 x 1/8
	9/16"	120449	5.27			
	5/8"	120450	5.22	3/16 x 3/32	3/16 x 3/32	3/16 x 3/16
	11/16"	120451	5.20			
	3/4"	120452	5.17			
	13/16"	120453	5.32			
	7/8"	120454	5.08			
	15/16"	120455	5.05	1/4 x 1/8	1/4 x 1/8	1/4 x 1/4
	1"	120456	5.00			
	1-1/16"	120457	4.95			
	1-1/8"	120458	4.90			
	1-3/16"	120459	4.83			
	1-1/4"	120460	4.77			

P/N's marked (+) are Integral Key Bushings

Bore sizes marked (#) will be supplied with 1/2" wide keyway unless the 5/8" wide keyway is specified when ordering

* Key furnished for these sizes ONLY

** Key not furnished for MM bores sizes

T-L FEATURES/BENEFITS PAGE PT6-2	T-L SPECIFICATION PAGE PT6-3	QD BUSHINGS PAGE PT6-16	GT BUSHINGS PAGE PT6-28
-------------------------------------	---------------------------------	----------------------------	----------------------------



SPECIFICATION

QD Bushings - Stock Bore

QD Bush Size	Bore	P/N	WT.	Bushing Keyway	Shaft Keyway REF	Key Size REF				
SF (cont)	1-5/16"	120461	4.71	5/16 x 5/32	5/16 x 5/32	5/16 x 5/16				
	1-3/8"	120462	4.61							
	1-7/16"	120463	4.57							
	1-1/2"	120464	4.48							
	1-9/16"	120465	4.42							
	1-5/8"	120466	4.32							
	3/8 x 3/16	1-11/16"	120467	4.31	3/8 x 3/16	3/8 x 3/16	3/8 x 3/8			
		1-3/4"	120468	4.16						
		1-13/16"	120469	4.06						
		1-7/8"	120470	4.00						
		1-15/16"	120471	3.87						
		2"	120472	3.78						
		2-1/16"	120473	3.70						
		2-1/8"	120474	3.57						
		2-3/16"	120475	3.45						
		2-1/4"	120476	3.38						
		2-5/16"	120477	3.32				5/8 x 5/16	5/8 x 5/16	5/8 x 5/8
		2-3/8"	120478	3.39						
		2-7/16"	120479	3.26						
		2-1/2"	120592	3.16						
		2-5/8"	120482	2.91						
		2-11/16"	120483	2.80						
		2-3/4"	120484	2.59				5/8 x 1/16	5/8 x 5/16	5/8 x 3/8 *
		2-13/16"	120485	2.50						
	2-7/8"	120486	2.35							
	2-15/16"	120487	2.22							
	28MM	120124	5.00	8 X 3.3MM	8 X 4MM	8 X 7MM				
	30MM	120125	4.90							
	32MM	120126	4.77							
	35MM	120127	4.61							
38MM	120128	4.48								
40MM	120129	4.42								
42MM	120130	4.32	12 X 3.3MM	12 X 5MM	12 X 8MM					
45MM	120071	4.16								
48MM	120131	4.00								
50MM	120132	3.87								
55MM	120133	3.57								
60MM	120134	3.39								
E	7/8"	120488	11.80	3/16 x 3/32	3/16 x 3/32	3/16 x 3/16				
	1"	120490	11.65							
	1-1/8"	120492	11.46							
	1-3/16"	120493	11.40	1/4 x 1/8	1/4 x 1/8	1/4 x 1/4				
	1-1/4"	120494	11.33							
	1-5/16"	120495	11.26							
	1-3/8"	120496	11.20	5/16 x 5/32	5/16 x 5/32	5/16 x 5/16				
	1-7/16"	120497	11.13							
	1-1/2"	120498	10.86							
	1-9/16"	120499	10.82							
	1-5/8"	120500	10.69							
	1-11/16"	120501	10.56							
	1-3/4"	120502	10.46	3/8 x 3/16	3/8 x 3/16	3/8 x 3/8				

QD Bush Size	Bore	P/N	WT.	Bushing Keyway	Shaft Keyway REF	Key Size REF		
E (cont)	1-13/16"	120503	10.16	1/2 x 1/4	1/2 x 1/4	1/2 x 1/2		
	1-7/8"	120504	10.16					
	1-15/16"	120505	10.16					
	2"	120506	10.01					
	2-1/16"	120507	9.85					
	2-1/8"	120508	9.73					
	2-3/16"	120509	9.42					
	2-1/4"	120510	9.42	5/8 x 5/16	5/8 x 5/16	5/8 x 5/8		
	2-5/16"	120511	9.07					
	2-3/8"	120512	8.95					
	2-7/16"	120513	8.77					
	2-1/2"	120514	8.72					
	2-5/8"	120516	8.37					
	2-11/16"	120517	8.05					
	2-3/4"	120518	7.90	3/4 x 3/8	3/4 x 3/8	3/4 x 3/4		
	2-13/16"	120519	7.70					
	2-7/8"	120520	7.32					
	2-15/16"	120521	7.53					
	3"	120522	7.31					
	3-1/8"	120524	6.90					
	3-3/16"	120525	6.69					
	3-1/4"	120526	6.48	7/8 x 1/8	7/8 x 7/16	7/8 x 9/16 *		
	3-5/16"	120527	6.10					
	3-3/8"	120528	6.21					
	3-7/16"	120529	5.86					
	3-1/2"	120530	5.73					
	28MM	120073	10.20				8 X 3.3MM	8 X 4MM
	30MM	120074	10.20					
	32MM	120075	10.20					
	35MM	120135	10.20					
38MM	120136	10.00						
40MM	120137	10.88						
42MM	120138	9.80	12 X 3.3MM	12 X 5MM	12 X 8MM			
45MM	120141	9.60						
48MM	120139	10.26						
50MM	120140	10.06						
55MM	120142	9.56						
60MM	120143	9.10						
65MM	120144	9.60	18 X 4.4MM	18 X 7MM	18 X 11MM			
70MM	120145	7.87						
75MM	120146	7.28						
1"	120531	19.41				1/4 x 1/8	1/4 x 1/8	1/4 x 1/4
1-1/8"	120533	19.15						
1-3/16"	120534	18.00						
1-1/4"	120535	18.99						
1-3/8"	120537	18.68						
1-7/16"	120538	18.56						
1-1/2"	120539	18.48	3/8 x 3/16	3/8 x 3/16	3/8 x 3/8			
1-9/16"	120540	18.40						
1-5/8"	120541	18.15						
1-11/16"	120542	17.91						
1-3/4"	120543	16.77						
1-13/16"	120544	17.62						
1-7/8"	120545	16.41	1/2 x 1/4	1/2 x 1/4	1/2 x 1/2			
1-15/16"	120546	16.00						
2"	120547	16.00						
2-1/16"	120548	16.00						
2-1/8"	120549	15.95						
2-3/16"	120550	15.95						
2-1/4"	120551	15.95						

P/N's marked (+) are Integral Key Bushings

Bore sizes marked (#) will be supplied with 1/2" wide keyway unless the 5/8" wide keyway is specified when ordering

* Key furnished for these sizes ONLY

** Key not furnished for MM bores sizes

SPECIFICATION



QD Bushings - Stock Bore

QD Bush Size	Bore	P/N	WT.	Bushing Keyway	Shaft Keyway REF	Key Size REF
F (cont)	2-5/16"	120552	15.95	5/8 x 5/16	5/8 x 5/16	5/8 x 5/8
	2-3/8"	120553	15.50			
	2-7/16"	120554	15.50			
	2-1/2"	120555	15.37			
	2-5/8"	120557	14.86			
	2-11/16"	120558	14.50			
	2-3/4"	120559	14.37	3/4 x 3/8	3/4 x 3/8	3/4 x 3/4
	2-13/16"	120560	14.00			
	2-7/8"	120561	14.02			
	2-15/16"	120562	13.47			
	3"	120563	13.20			
	3-1/8"	120565	12.67			
	3-3/16"	120566	12.50	7/8 x 3/16	7/8 x 7/16	7/8 x 5/8 *
	3-1/4"	120567	12.00			
	3-3/8"	120569	12.00			
	3-7/16"	120570	11.88			
	3-1/2"	120571	11.40			
	3-5/8"	120573	10.53			
	3-11/16"	120574	14.00	1 x 1/8	1 x 1/2	1 x 5/8 *
	3-3/4"	120575	9.89			
3-7/8"	120577	9.26				
3-15/16"	120578	9.23				
4"	120579	7.96				
None						
45MM	120076	16.20	14 X 3.8MM	14 X 5.5MM	14 X 9MM	
48MM	120147	16.00				
50MM	120148	15.80				
55MM	120149	15.80	16 X 4.3MM	16 X 6MM	16 X 10MM	
60MM	120150	15.80				
65MM	120151	14.30				
70MM	120152	14.30	20 X 4.9MM	20 x 7.5MM	20 X 12MM	
75MM	120153	13.50				
80MM	120154	12.55				
85MM	120155	10.60	22 X 5.4MM	22 X 9MM	22 X 14MM	
90MM	120077	10.50				
25 X 5.4MM						
J	1-1/2"	120600	28.97	3/8 x 3/16	3/8 x 3/16	3/8 x 3/8
	1-5/8"	120601	28.61			
	1-3/4"	120603	28.28			
	1-7/8"	120604	27.79	1/2 x 1/4	1/2 x 1/4	1/2 x 1/2
	1-15/16"	120605	27.53			
	2"	120606	27.33			
	2-1/8"	120607	26.74			
	2-3/16"	120608	26.37			
	2-1/4"	120609	26.32			
	2-3/8"	120610	25.65	5/8 x 5/16	5/8 x 5/16	5/8 x 5/8
	2-7/16"	120611	25.52			
	2-1/2"	120612	25.05			
	2-5/8"	120613	24.50			
	2-11/16"	120614	24.18			
	2-3/4"	120615	23.86			

QD Bush Size	Bore	P/N	WT.	Bushing Keyway	Shaft Keyway REF	Key Size REF
J (cont)	2-7/8"	120617	23.15	3/4 x 3/8	3/4 x 3/8	3/4 x 3/4
	2-15/16"	120618	23.07			
	3"	120619	22.43			
	3-1/8"	120620	21.68			
	3-3/16"	120621	21.35			
	3-1/4"	120622	20.98			
	3-3/8"	120623	20.33	7/8 x 7/16	7/8 x 7/16	7/8 x 7/8
	3-7/16"	120624	21.13			
	3-1/2"	120625	19.58			
	3-5/8"	120626	18.44			
	3-11/16"	120627	18.04			
	3-3/4"	120628	17.62			
	3-7/8"	120629	17.94	1 x 1/8	1 x 1/2	1 x 5/8 *
	3-15/16"	120630	17.38			
	4"	120631	16.62			
	4-1/8"	120632	15.69			
	4-3/16"	120633	14.55			
	4-1/4"	120634	14.68			
	4-3/8"	120635	14.00	14 X 3.8MM	14 X 5.5MM	14 X 9MM
	4-7/16"	120636	13.49			
	4-1/2"	120637	12.67			
	50MM	120157	26.50			
	55MM	120158	25.60			
	60MM	120159	25.82			
	65MM	120160	25.25	18 X 4.4MM	18 X 7MM	18 X 11MM
	70MM	120161	24.04			
	75MM	120162	21.90			
	80MM	120163	20.90	20 X 4.9MM	20 x 7.5MM	20 X 12MM
	85MM	120164	20.52			
	90MM	120165	18.10			
	95MM	120166	16.80	22 X 5.4MM	22 X 9MM	22 X 14MM
	100MM	120167	16.50			
26 X 6.4MM						
M	2"	119900	62.65	1/2 x 1/4	1/2 x 1/4	1/2 x 1/2
	2-1/8"	119901	62.65			
	2-3/16"	119902	61.58			
	2-1/4"	119903	61.14	5/8 x 5/16	5/8 x 5/16	5/8 x 5/8
	2-3/8"	119904	59.50			
	2-7/16"	119905	59.35			
	2-1/2"	119906	59.21			
	2-5/8"	119907	58.69			
	2-3/4"	119908	57.86			
	2-7/8"	119909	56.57	3/4 x 3/8	3/4 x 3/8	3/4 x 3/4
	2-15/16"	119910	56.17			
	3"	119911	56.10			
	3-1/8"	119912	55.82			
	3-3/16"	119913	53.84			
	3-1/4"	119914	53.42			
	3-3/8"	119915	52.06	7/8 x 7/16	7/8 x 7/16	7/8 x 7/8
	3-7/16"	119916	52.04			
	3-1/2"	119917	51.12			
	3-5/8"	119918	50.08			
	3-11/16"	119919	49.00			
3-3/4"	119920	48.47				
3-7/8"	119921	47.03	1 x 1/2	1 x 1/2	1 x 1	
3-15/16"	119922	46.26				
4"	119923	46.09				
4-1/8"	119924	44.31				
4-3/16"	119925	43.64				
4-1/4"	119926	42.81				

P/N's marked (+) are Integral Key Bushings

Bore sizes marked (#) will be supplied with 1/2" wide keyway unless the 5/8" wide keyway is specified when ordering

* Key furnished for these sizes ONLY

** Key not furnished for MM bores sizes

T-L FEATURES/BENEFITS PAGE PT6-2	T-L SPECIFICATION PAGE PT6-3	QD BUSHINGS PAGE PT6-16	GT BUSHINGS PAGE PT6-28
-------------------------------------	---------------------------------	----------------------------	----------------------------



SPECIFICATION

QD Bushings - Stock Bore

QD Bush Size	Bore	P/N	WT.	Bushing Keyway	Shaft Keyway REF	Key Size REF
M (cont)	4-3/8"	119927	41.46			
	4-7/16"	119928	40.60	1 x 1/2	1 x 1/2	1 x 1
	4-1/2"	119929	40.27			
	4-11/16"	119930	37.12	1-1/4 x 5/8	1-1/4 x 5/8	1-1/4 x 1-1/4
	4-3/4"	119931	37.00			
	4-7/8"	119932	36.89			
	4-15/16"	119933	36.13			
	5"	119934	35.66			
	5-1/8"	119899	35.00	1-1/4 x 1/4	1-1/4 x 5/8	1-1/4 x 7/8 *
	5-3/16"	119894	35.00			
	5-1/4"	119935	30.00			
	5-7/16"	119936	30.00			
	5-1/2"	119937	29.00			
N	2-7/16"	119940	87.57	5/8 x 5/16	5/8 x 5/16	5/8 x 5/8
	2-15/16"	119941	83.00	3/4 x 3/8	3/4 x 3/8	3/4 x 3/4
	3-7/16"	119942	80.00			
	3-1/2"	119980	80.00	7/8 x 7/16	7/8 x 7/16	7/8 x 7/8
	3-3/4"	119943	80.00			
	3-7/8"	119944	80.00			
	3-15/16"	119945	80.00			
	4"	119946	80.00			
	4-3/16"	119947	80.00	1 x 1/2	1 x 1/2	1 x 1
	4-1/4"	119948	80.00			
	4-3/8"	119982	79.00			
	4-7/16"	119949	78.00			
	4-1/2"	119950	77.00			
	4-11/16"	119983	76.00			
	4-3/4"	119951	75.00	1-1/4 x 5/8	1-1/4 x 5/8	1-1/4 x 1-1/4
	4-7/8"	119952	74.00			
	4-15/16"	119953	73.00			
	5"	119954	72.00			
	5-1/8"	119955	71.00			
	5-3/16"	119986	70.50	1-1/4 x 1/4	1-1/4 x 5/8	1-1/4 x 7/8 *
5-1/4"	119956	70.00				
5-7/16"	119957	52.19				
5-1/2"	119958	49.02				
5-3/4"	119959	49.00				
5-7/8"	119960	44.00	1-1/2 x 1/8	1-1/2 x 3/4	1-1/2 x 7/8 *	
5-15/16"	119961	43.00				
6"	119962	42.00				

QD Bush Size	Bore	P/N	WT.	Bushing Keyway	Shaft Keyway REF	Key Size REF
P	3-7/16"	119965	134.00	7/8 x 7/16	7/8 x 7/16	7/8 x 7/8
	3-15/16"	119966	122.00			
	4"	119987	122.00	1 x 1/2	1 x 1/2	1 x 1
	4-7/16"	119967	122.40			
	4-1/2"	119968	121.00			
	4-3/4"	119969	120.00			
	4-7/8"	119985	120.00			
	4-15/16"	119970	119.00	1-1/4 x 5/8	1-1/4 x 5/8	1-1/4 x 1-1/4
	5"	119971	115.00			
	5-3/16"	119984	114.00			
	5-7/16"	119972	113.00			
	5-1/2"	119973	100.00			
	5-15/16"	119974	94.00			
	6"	119975	93.70			
	6-7/16"	119976	83.50	1-1/2 x 1/4	1-1/2 x 3/4	1-1/2 x 1 *
	6-1/2"	119977	80.50			
	7"	119978	68.00	1-3/4 x 1/8	1-3/4 x 3/4	1-3/4 x 7/8 *
W	4-1/4"	120180	260.00			
	4-7/16"	120181	256.60	1 x 1/2	1 x 1/2	1 x 1
	4-1/2"	120182	255.40			
	4-3/4"	120183	250.00			
	5"	120186	244.30	1-1/4 x 5/8	1-1/4 x 5/8	1-1/4 x 1-1/4
	5-3/8"	120188	235.30			
	5-1/2"	120189	232.20			
	5-3/4"	120190	225.70			
	5-7/8"	120191	222.30			
	5-15/16"	120192	220.00	1-1/2 x 3/4	1-1/2 x 3/4	1-1/2 x 1-1/2
	6"	120193	218.90			
	6-1/2"	120194	215.00			
	6-3/4"	120328	210.00			
	7"	120196	184.90	1-3/4 x 3/4	1-3/4 x 3/4	1-3/4 x 1-1/2
	7-1/4"	120197	184.40			
7-1/2"	120198	175.80				
7-3/4"	120199	172.00	2 x 1/4	2 x 3/4	2 x 1 *	
8"	120200	159.70				

S ▼ Bushings size available please call Dodge for information

P/N's marked (+) are Integral Key Bushings

Bore sizes marked (#) will be supplied with 1/2" wide keyway unless the 5/8" wide keyway is specified when ordering

* Key furnished for these sizes ONLY

** Key not furnished for MM bores sizes

T-L FEATURES/BENEFITS PAGE PT6-2	T-L SPECIFICATION PAGE PT6-3	QD BUSHINGS PAGE PT6-16	GT BUSHINGS PAGE PT6-28
-------------------------------------	---------------------------------	----------------------------	----------------------------

SPECIFICATION



QD Reborable

QD Bush Size	Sintered Steel		Cast Iron		Ductile Iron	
	Bore	P/N	Bore	P/N	Bore	P/N
QT (L)	3/8"	120595				
JA	1/2"	120050				
SH	1/2"	120051			1/2"	119876
SDS	1/2"	120052			1-7/16"	119877
SD	1/2"	120053			1-9/16"	119878
SK	1/2"	120054			2"	119879
SF	1/2"	120055			2-5/16"	119880
E			7/8"	120056	7/8"	119881
F			1"	120057	1"	119882
J			1-1/2"	120058	1-1/2"	119883
M			2"	119938	2"	119884
N			2-7/16"	119963	2-7/16"	119885
P			3-7/16"	119979	3-7/16"	119886
W			4"	120276		
S			5-1/2"	394059		

NOTE: All reborable bushings are stocked without sawsplit to facilitate re-machining. Sawsplit must be made in bushing to allow it to compress for proper gripping of the shaft. Factory rebore and keyseat service as listed in MLP price book includes sawsplit.

QD - Maximum Bore Capacities

QD Bush Size	Sintered Steel			Cast Iron			Ductile Iron			
	Full Key	Shallow Key	Metric	Full Key	Shallow Key	Metric	Full Key	Shallow Key	No Key*	Metric
QT (L)										
JA	1"	1-1/16"	25				1"	1-3/16"	1-1/4"	25
SH	1-1/4"	1-1/4"	30				1-3/8"	1-5/8"	1-11/16"	35
SDS	1-9/16"	1-5/8"	40				1-5/8"	1-15/16"	2"	42
SD	1-9/16"	1-9/16"	40				1-11/16"	1-15/16"	2"	42
SK	2"	2-1/16"	50				2-1/2"	2-1/2"	2-5/8"	55
SF	2-1/4"	2-3/8"	55				2-5/16"	2-15/16"	2-15/16"	65
E				2-3/4"	3"	70	2-7/8"	3-1/2"	3-1/2"	89
F				3-1/4"	3-7/16"	90	3-1/4"	3-15/16"	4"	101
J				3-3/4"	3-7/8"	100	3-3/4"	4-1/2"	4-1/2"	114
M				4-3/4"	5"	120	4-3/4"	5-1/2"	5-1/2"	139
N				5"	5-1/4"	130	5"	6"	6"	149
P				5-1/2"	7"	160	5-1/2"	7"	7"	177
W				6-1/2"	7"	165	6-1/2"	8-1/2"	8-1/2"	216
S				8-1/4"	8-1/4"	209	8-1/4"	10"	10"	250

NOTE: ISO STANDARD METHOD FOR MEASURING KEYSEAT DEPTH
MM Bore and Keyway dimensions conform to ISO standard recommendation R773, for "Free" fit

REFERENCE:

1 inch = 25.4 millimeters
1 millimeter = .03937 inches

* Verify torque capacity: Contact Application Engineering for assistance

T-L FEATURES/BENEFITS PAGE PT6-2	T-L SPECIFICATION PAGE PT6-3	QD BUSHINGS PAGE PT6-16	GT BUSHINGS PAGE PT6-28
-------------------------------------	---------------------------------	----------------------------	----------------------------