



# Roots® RVS & VJ Water Sealed Vacuum Blower: 10"-20" Splash Lubricated

Installation and Operation Manual



---

## Contents

Information Summary.....	2	Operation.....	16
Warranty and Limitation of Liability .....	2	Troubleshooting.....	21
Operating Characteristics.....	3-4	Maintenance/Replacements.....	23
Operating Limitations .....	4	Troubleshooting & Repairs .....	23
Installation .....	5	Sectional Drawings .....	24-28
Lubrication .....	14	Parts List.....	29

### Do These Things To Get The Most From Your ROOTS™ Blower

- Check shipment for damage. If found, file claim with carrier and notify nearest Sales Office. See List on last page.
- Unpack shipment carefully and check contents against packing List. Notify Sales Office if shortage appears.
- Store in a clean, dry location until ready for installation. Lift by methods discussed under installation to avoid straining or distorting the equipment. Keep covers on all openings. Protect against weather and corrosion if outdoor storage is necessary.
- Read **LIMITATIONS and INSTALLATION** sections in this manual and complete the installation.
- Provide for adequate safeguards against accidents to persons working on or near the equipment during both installation and operation. **SEE SAFETY PRECAUTIONS.**
- Install all equipment correctly. Foundation design must be adequate and piping carefully done. Use recommended accessories for operating protection.
- Make sure both driving and driven equipment is correctly lubricated before start-up. **See LUBRICATION.**
- Read starting checkpoints under **OPERATION.** Run equipment briefly to check for installation errors and make corrections. Follow with a trial run under normal operating conditions.
- In event of trouble during installation or operation, do not attempt repairs of Roots furnished equipment. Notify nearest Sales Office giving all nameplate information plus an outline of operating conditions and a description of the trouble.
- Unauthorized attempts at equipment repair may void Manufacturer's warranty. It is recommended that such work be limited to the operations described in this manual, using Factory Parts. Good inspection and maintenance practices should reduce the need for repairs.

---

## Operating Characteristics

Roots units covered in this manual are designated as type RVS/VJ vacuum blowers and range in size from 10 inches thru 20 inches gear diameter. They are of the basic rotary lobe design, and are equipped with an effective splash oil lubrication system.

The Roots RVS/VJ rotary lobe vacuum blower is a positive displacement unit whose pumping capacity is determined by size, operating speed, vacuum-pressure conditions, and rate of sealing liquid passage. It employs two double-lobe impellers mounted on parallel shafts and rotating in opposite directions within a cylinder closed at the ends by headplates. As the impellers rotate, they attempt to draw air into the inlet opening on one side of the cylinder and force it out the opposite side or discharge opening. The vacuum level developed at the blower inlet depends, therefore, on the restrictions to air flow in the connected inlet system or equipment.

Effective sealing of the blower inlet area from the discharge area is accomplished by the use of very small operating clearances. (This feature also eliminates rubbing contact between rotating and stationary parts, hence, internal lubrication is not required.) Clearances between the impellers during rotation are maintained by a pair of accurately machined timing gears, mounted on the two shafts extending outside the air chamber.

Operation of a rotary lobe RVS/VJ vacuum blower is illustrated in Figure 1, where air flow is right to left from inlet to discharge with the lower impeller rotating clockwise. In Position 1 it is delivering a known volume (A) to the discharge, while space (B) between the upper impeller and cylinder wall is being filled. Counterclockwise rotation of this impeller then traps equal volume (B) in Position 2, and further rotation delivers it to the discharge in Position 3. At the same time, another similar volume is forming under the lower impeller, and will be discharged when rotation reaches Position 1 again.

One complete revolution of the driving shaft alternately traps four equal and known volumes of air (two by each impeller) and pushes them thru to the discharge. The pumping capacity of a lobe blower operating at a constant speed therefore

remains relatively independent of reasonable inlet or discharge pressure variations. To change capacity it is necessary to change speed of rotation or bleed air into the inlet.

No attempt should ever be made to control capacity by means of a throttle valve in the intake or discharge piping. This increases the power load on the driver, and may seriously damage the blower. If a possibility exists that flow into the blower inlet may be cut off during normal operation of a process, an adequate vacuum relief valve should be installed in the inlet line near the blower. A pressure type relief valve in the discharge line near the blower is also recommended for protection against cut-off or blocking in this line.

When a belt drive is employed, blower speed can usually be adjusted to obtain desired capacity by changing the diameter of one or both sheaves. In a direct coupled arrangement, a variable speed motor or transmission is required.

The vacuum level obtainable from any blower or combination is determined largely by the amount of upstream flow restriction relative to the effective pumping capacity. Before attempting to change capacity or operating conditions from those specified in the original order, contact the nearest Roots Sales Office for specific information applying to the particular order. In all cases, operating conditions must be maintained within the approved range of vacuum levels and speeds as stated under **LIMITATIONS**.

Roots RVS/VJ vacuum blowers can ingest a limited quantity of liquid without damage. This permits introduction of sealing water at the blower inlet to improve operating efficiency and reduce internal temperature rise. Part or all of the water required for sealing purposes may be present in the process being served by the blower. If this water input rate is known in terms of gallons per minute (litres per min.) and is less than the Maximum Continuous Rate shown in Table 1, spray injection of water may be reduced accordingly. As a safety precaution, it is recommended that at least a small quantity of water always be injected regardless of normal process water. This will reduce the likelihood of running dry at some vacuum level that will cause damage.

Where liquid flow rates from a process are in excess of the Maximum Continuous Rate in Table 1, some method of water removal should be employed. This can be a drain leg in the blower inlet piping, or a receiver and water pump arrangement. On wet vacuum filter service a vacuum receiver with filtrate removal system is recommended.

Should water input rates exceed the Maximum Continuous values listed in Table 1 blower operation will become noisy and rough. If continued for an extended period of time, mechanical damage to the blower may result. Such high rates will put too much water in the blower, and this will increase horsepower requirements to a point where the driver may become overloaded.

A RVS/JV vacuum blower should not be expected to handle solid particles entrained in the sealing water or air flow on any continuous basis. If material build-up on the surfaces of the impellers and cylinder occurs, it must be removed to avoid internal contacts and resultant damage. Suggested methods for preventing scale build up are outlined under OPERATION.

Note - If a RVS/VJ blower is to be converted from water sealed operation to use as a dry vacuum blower, all scale or dirt deposits must first be completely removed from all internal surfaces. The blower should then be inspected to verify proper clearances. Check with Factory for allowable vacuum level for dry RVS/VJ blower.

**Figure 1 - Flow Through an RVS/VJ Blower**

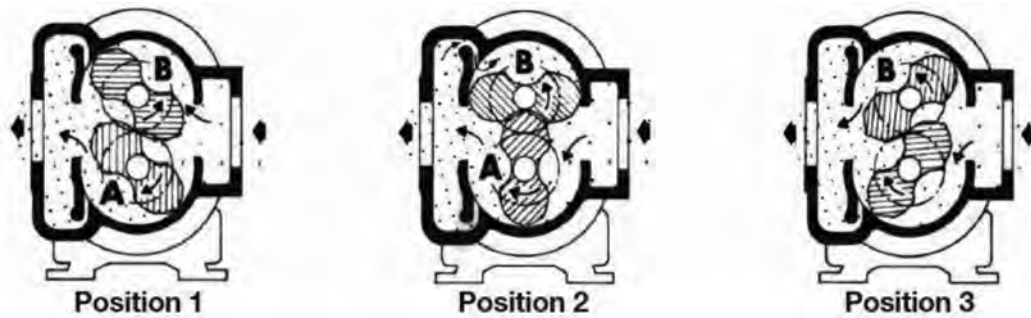

## Operating Limitations

To establish and maintain continued satisfactory performance, a Roots RVS/VJ vacuum blower must be operated within certain approved limiting conditions. The Manufacturer's warranty is, of course, contingent on such operation.

Maximum limits for vacuum, temperature and speed, along with recommended and maximum sealing water flow rates are specified in Table 1 for various standard sizes of single stage RVS/VJ blowers. These limits apply to all blowers of normal construction. Do not exceed any one of these limits.

Example: Assuming water sealed operation, the temperature rise probably will be considerably below the allowable maximum. If the blower operating speed is also below the maximum, the inlet vacuum then becomes the limiting factor to be watched. In other

words, the operating limit is always to be determined by the maximum rating reached first. It can be vacuum pressure, speed or temperature.

**TEMPERATURE RISE** - Normally this is not a problem in a wet vacuum blower since the water used for sealing purposes also removes the heat of compression. However, the RVS/VJ blowers may be operated with the maximum temperature rises listed in Table 1 providing speed and inlet vacuum limits are not exceeded.

**VACUUM** - With the blower discharge connected directly to atmospheric pressure, the suction or vacuum load on the pump inlet as measured inches of mercury (kPa) must not be greater than the value for any specific frame size.

---

**SPEED RANGE-RVS/VJ** vacuum blowers may be operated at speeds up to the maximum listed for each gear diameter or frame series. They may be direct coupled to suitable constant speed drivers, or belt driven to obtain intermediate speeds.

## Installation

Technical assistance at installation by a factory Service Engineer is usually not required for the smaller units, frame series 1000 through 1400. Workmen with general experience in installing heavy machinery should be able to complete a satisfactory installation. Information in this manual is supplemented by the more detailed discussions of foundations and piping in API recommended practice 686 and the Compressed Air and Gas Handbook, published by the Compressed Air and Gas Institute, New York City and the American Petroleum Institute, Washington, D.C. However, a Service Engineer may be employed for assistance or for final checking of an installation.

Handling of the equipment should be accomplished by methods conforming to safe practice for the weight involved. Weight of a bare unit, without base plate, driver or accessories will range from about 1 ton (910 kg) for the smallest to approximately 7 tons (6350 kg). On such units, an eyebolt is provided near each end for lifting. A unit mounted on a base plate should be lifted only by the four lifting lugs provided.

Before lifting with eyebolts, test one for tightness and fractures by tapping with a hammer. Direction of pull on the bolts during lift should be nearly vertical. Since a considerable cable angle will usually be unavoidable, place a stiff spreader between the eyebolts to take the side strain, and adjust cable lengths so that the unit is approximately level during the lift. A harness featuring four lifting hooks is required to lift base-mounted units. After inserting the hooks in the lifting lugs, block the chains out on the sides to avoid placing the unit under strain. At the same time, adjust lengths to produce a level lift.

**LOCATION** of the installation is generally not a critical matter. A clean, dry and protected indoor location is to be preferred. However, an outdoor location will give satisfactory service if correct lubrication for expected temperatures is provided. Effect of such a location on driver and other equipment must also be considered.

**PROTECTION** of internal machined surfaces against normal atmospheric corrosion is normally provided at the factory, using a vaporizing inhibitor. Markings on the range covers will indicate this protection. Maximum period of protection is one year under average conditions, if range covers and closing seals are not removed. Protection against chemical or salt water atmosphere is not provided. Leave covers and tape seals over all openings as long as possible during installation to avoid loss of protection.

If there is to be an extended period between installation and start up, the following steps should be taken to insure corrosion protection:

1. Coat internal of cylinder, gearbox and drive end bearing covers with a vapor phase rust inhibiting liquid such as Nox-Rust VCI-10. Repeat once a year or as conditions may require. VCI-10 is oil soluble and does not have to be removed before lubricating. If desired, VCI-10 may be removed from within the cylinder shortly before start up by spraying a fine mist of petroleum solvent through the blower while it is running at a slow speed with open inlet and discharge, or it can remain in the blower if it is not harmful to the operation of the connected system. VCI-10 is a product of Daubert Chemical Co., Oak Brook, IL.
2. Paint shaft extension, inlet and discharge angles, and all other exposed surfaces with Nox-Rust X-110 or equivalent.
3. Seal inlet, discharge, and vent openings. It is not recommended that the unit be set in place, piped to the system, and allowed to remain idle for extended periods. If any part is left open to the atmosphere, the VCI-10 vapor will escape and lose its effectiveness.
4. Units are not to be subjected to excessive vibration during storage.
5. Rotate drive shaft three or four revolutions every two weeks.
6. Prior to start up, remove range covers on both inlet and discharge and inspect internal to insure absence of rust. Check all internal clearances. Also, at this time, remove gearbox and bearing covers and inspect gear teeth and bearings for rust.

Table 1A - Maximum Allowable Operating Conditions (22 PSL)

Frame Size	Speed RPM <sup>1</sup>	Inlet Vacuum		Temperature Rise		Sealing Water Flow <sup>2</sup>	
		Inches Hg.	kPa	°F	°C	GPM	LPM
1006	1440 (1800)	24.0	81	100	38	10	37.9
1009	1440 (1800)	24.0	81	100	38	10	37.9
1012	1440 (1800)	24.0	81	100	38	10	37.9
1016	1440 (1800)	24.0	81	100	38	10	37.9
1018	1440 (1800)	23.8	81	100	38	10	37.9
1021	1440 (1800)	21.2	72	100	38	10	37.9
1024	1440 (1800)	18.7	63	100	38	10	37.9
1030	1440 (1800)	14.8	50	100	38	10	37.9
1212	1200 (1500)	24.0	81	100	38	12	45.4
1216	1200 (1500)	24.0	81	100	38	12	45.4
1220	1200 (1500)	24.0	81	100	38	12	45.4
1222	1200 (1500)	23.8	81	100	38	12	45.4
1225	1200 (1500)	21.3	72	100	38	12	45.4
1228	1200 (1500)	18.7	63	100	38	12	45.4
1236	1200 (1500)	14.8	50	100	38	12	45.4
1412	1030 (1285)	24.0	81	100	38	14	53.0
1414	1030 (1285)	24.0	81	100	38	14	53.0
1418	1030 (1285)	24.0	81	100	38	14	53.0
1422	1030 (1285)	24.0	81	100	38	14	53.0
1425	1030 (1285)	24.0	81	100	38	14	53.0
1428	1030 (1285)	22.4	76	100	38	14	53.0
1431	1030 (1285)	20.0	68	100	38	14	53.0
1435	1030 (1285)	17.9	61	100	38	14	53.0
1442	1030 (1285)	14.8	50	100	38	14	53.0
1616	900 (1130)	24.0	81	100	38	16	60.6
1620	900 (1130)	24.0	81	100	38	16	60.6
1625	900 (1130)	24.0	81	100	38	16	60.6
1627	900 (1130)	24.0	81	100	38	16	60.6
1630	900 (1130)	23.8	81	100	38	16	60.6
1633	900 (1130)	21.5	73	100	38	16	60.6
1636	900 (1130)	19.9	67	100	38	16	60.6
1639	900 (1130)	18.3	62	100	38	16	60.6
1643	900 (1130)	15.9	54	100	38	16	60.6
1645	900 (1130)	15.9	54	100	38	16	60.6
1648	900 (1130)	14.8	50	100	38	16	60.6
1821	800 (1000)	24.0	81	100	38	18	68.1
1824	800 (1000)	24.0	81	100	38	18	68.1
1827	800 (1000)	24.0	81	100	38	18	68.1
1830	800 (1000)	24.0	81	100	38	18	68.1
1833	800 (1000)	23.8	81	100	38	18	68.1
1838	800 (1000)	21.2	72	100	38	18	68.1
1841	800 (1000)	19.5	66	100	38	18	68.1
1845	800 (1000)	17.9	61	100	38	18	68.1
1849	800 (1000)	16.3	55	100	38	18	68.1
1854	801 (1000)	14.8	50	100	38	18	68.1
2022	720 (900)	24.0	81	100	38	20	75.7
2026	720 (900)	24.0	81	100	38	20	75.7
2030	720 (900)	24.0	81	100	38	20	75.7
2033	720 (900)	24.0	81	100	38	20	75.7
2037	720 (900)	23.8	81	100	38	20	75.7
2040	720 (900)	22.4	76	100	38	20	75.7
2044	720 (900)	20.3	69	100	38	20	75.7
2047	720 (900)	19.1	65	100	38	20	75.7
2050	720 (900)	17.9	61	100	38	20	75.7
2055	720 (900)	16.1	55	100	38	20	75.7
2057	720 (900)	15.7	53	100	38	20	75.7
2060	720 (900)	14.8	50	100	38	20	75.7

Notes:

<sup>1</sup> Blowers may be run above the speed shown to a maximum speed as shown in brackets ( ). It is recommended that if the speed showing exceeded, a harder impeller material, >CI-3 (65/45/12 ductile iron) should be used.

<sup>2</sup> Includes injected and process water. Total GPM (liters per min.) is for either single stage or two stage operation. For two stage VJ-2 units, injected water flow should be divided between the first and second stage as follows: 2/3 to the first stage and 1/3 to the second stage of the recommended flow for the first stage. See “Optimization of Water Injection” in Operation Section.

Table 1B - Maximum Allowable Operating Conditions (40 PSL)

Frame Size	Speed RPM <sup>1</sup>	Inlet Vacuum		Temperature Rise		Sealing Water Flow <sup>2</sup>	
		Inches Hg.	kPa	°F	°C	GPM	LPM
2022	720 (900)	24.0	81	100	38	20	75.7
2026	720 (900)	24.0	81	100	38	20	75.7
2028.5	720 (900)	24.0	81	100	38	20	75.7
2030	720 (900)	24.0	81	100	38	20	75.7
2033	720 (900)	24.0	81	100	38	20	75.7
2037	720 (900)	24.0	81	100	38	20	75.7
2040	720 (900)	24.0	81	100	38	20	75.7
2044	720 (900)	24.0	81	100	38	20	75.7
2047	720 (900)	24.0	81	100	38	20	75.7
2050	720 (900)	24.0	81	100	38	20	75.7
2053	720 (900)	24.0	81	100	38	20	75.7
2055	720 (900)	24.0	81	100	38	20	75.7
2057	720 (900)	24.0	81	100	38	20	75.7
2060	720 (900)	24.0	81	100	38	20	75.7
2064	720 (900)	24.0	81	100	38	20	75.7
2070	720 (900)	23.2	79	100	38	20	75.7
2072	720 (900)	22.6	77	100	38	20	75.7
2077	720 (900)	21.0	71	100	38	20	75.7
2080	720 (900)	20.4	69	100	38	20	75.7

Notes:

<sup>1</sup> Blowers may be run above the speed shown to a maximum speed as shown in brackets ( ). It is recommended that if the speed showing exceeded, a harder impeller material, >CI-3 (65/45/12 ductile iron) should be used.

<sup>2</sup> Includes injected and process water. Total GPM (liters per min.) is for either single stage or two stage operation. For two stage VJ-2 units, injected water flow should be divided between the first and second stage as follows: 2/3 to the first stage and 1/3 to the second stage of the recommended flow for the first stage. See “Optimization of Water Injection” in Operation Section.

When ready to connect piping, remove main angle covers and inspect blower interior for presence of foreign particles or dirt adhering to machined surfaces. Clean out such material by washing carefully with a petroleum solvent then rotate impellers manually to make sure they turn freely. Also use the same solvent to remove the anti-rust coating from angle faces and any other surfaces. Note: interior cleaning is not required if no dirt is found.

**FOUNDATION** design depends on local soil conditions and several other factors and can only be discussed generally here. Additional information will be found in the publication referred to at the beginning of this section. For satisfactory operation of supported equipment, a concrete foundation must be rigid, must have minimum deflections, and must be free from resonant frequencies in the operating speed range of the equipment.

Length and width dimensions of the foundation should provide at least 6 inches (150 mm) from any edge to the nearest machine anchor bolt, as located from the certified manufacturer's general arrangement drawing. Depth dimension should be determined by design, but a minimum practical depth is considered to be twice the distance between shaft centers (or gear diameter) of the unit, or sufficient depth to attain a concrete mass a minimum of 1-1/2 times the weight of the blower and motor. The concrete block should be permitted to cure for a minimum of 28 days before the blower is grouted in place. Any block distortions during curing then will have little or no effect on equipment and alignment. To simplify machine leveling and provide good grouting bond, the top of the foundation should be struck-off as level as possible but left with a rough surface.

Spring-type vibration isolating mounting are not recommended for use directly between the operating equipment and the foundation. Where such mountings are required, they should be designed to carry a reinforced concrete slab on which the equipment is mounted. This slab must have good rigidity against bending and twisting, and the suspension system will require careful adjustment to produce a reasonably level condition during operation. All piping will require flexible sections and supports to reduce connection strains on the unit to a minimum.

Direct use of structural framing members for mounting is not recommended. If unavoidable, it should be restricted to units of the smaller frame sizes, and spring-type mountings should not be used. Structural members must be rigid, and will probably require reinforcement if part of a building. Noise transmission can be reduced by use of a cork isolating pad. This can be 1 to 2 inch (25-50 mm) thickness, bedding on a full steel plate attached to the structure and carrying rigid concrete slab on which the equipment is mounted.

**ANCHOR BOLTS** are to be placed within the foundation forms before concrete is poured. Foundation bolts installed as shown in Figure 3, with diameter and length as in Table 2 are recommended. The bolts must be located as accurately as possible from dimensions on certified installation drawing. To obtain a bolt location tolerance of 1/8" (3mm), use of drilled templates firmly secured to the foundation forms is recommended.

The bolt sleeves shown, if kept centered around the bolts and free of concrete, will allow bolts to be sprung enough to correct for small variations in bolt setting and machine drilling. The sleeves are filled in the final grouting operation. Bolt positions should be adjusted vertically so that the top ends will extend at least 1-1/2 diameters above the soleplate or taper washer, or as shown on the installation drawing.

Jack screws are provided to make leveling the height adjustments easier. Steel plates, approximately 4" x 4" x 1/2" (100 x 100 x 13 mm) should be placed

**Figure 2 - Typical Anchor Bolt Detail**

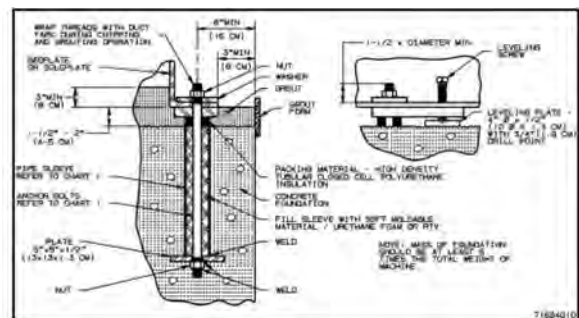

on the foundation under each jack screw location. Plates and anchor bolts are not furnished as standard accessories.



**LEVELING** is very important and should be performed with care, using a good machinists level having a ground glass bubble vial. A setting as level as possible in all directions is the result to be worked toward. Blowers should be leveled from drive shaft and pipe angles. Machined baseplates have pads running in both length and width directions. On soleplates, the machined top surfaces are used for leveling. Scrape pads or surfaces clean, and remove burrs on high points with a file.

When blower and driver have been factory mounted on a common baseplate, the assembly is to be treated as a unit for leveling purposes. Use the jack screws to establish grouting space under the base angles, and to level the base. Adjust these screws until the indicated variation from level does not exceed .001" per foot (.08 mm per m) in either length or width. Any variations should all be in the same direction, to minimize twist. The maximum allowable twist is considered to be .001" per horizontal foot (.08 mm per horizontal m) measured between any two sections of the base.

**Table 2A - Standard Anchor Bolts in Inches**

Unit Frame Size	For Soleplates				For Baseplates			
	Bolts		Sleeves		Bolts		Sleeves	
	Dia.	Lgth.	I.D.	Lgth.	Dia.	Lgth.	I.D.	Lgth.
1000	1	25	3	18	3/4	18	2-1/2	12
1200	1	25	3	18	3/4	18	2-1/2	12
1400	1-1/8	25	3	18	3/4	18	2-1/2	12
1600	1-1/8	25	3	25	1	25	3	18
1800	1-1/4	25	3	25	1	25	3	18
2000	1-1/4	25	3	25	1	25	3	18

**Table 2B - Standard Anchor Bolts in Centimeters**

Unit Frame Size	For Soleplates				For Baseplates			
	Bolts		Sleeves		Bolts		Sleeves	
	Dia.	Lgth.	I.D.	Lgth.	Dia.	Lgth.	I.D.	Lgth.
1000	2.4	64	7.5	46	2.0	46	6.5	30
1200	2.4	64	7.5	46	2.0	46	6.5	30
1400	3.0	64	7.5	46	2.0	46	6.5	30
1600	3.0	64	7.5	46	2.4	64	8.0	46
1800	3.0	64	7.5	46	2.4	64	8.0	46
2000	3.0	64	7.5	46	2.4	64	8.0	46

Units mounted on soleplates are to be leveled in a similar manner. The plates should be large enough to provide extensions for leveling in both length and width on the finished upper surfaces. Fasten the plates solidly to the blower feet, which are machined

at and parallel to each other, then install and level the blower carefully, using jack screws, shims or wedges for adjusting.

When a satisfactory condition of level is obtained, turn the anchor bolt nuts down snug but not tight. Elimination of twist here is very important, and minor adjustments can be made with shims directly under the blower feet.

**ALIGNMENT** of the drive shafts when the blower unit and its driver are direct coupled requires careful attention. This precaution will not only help insure satisfactory coupling operation, but will minimize chances for damage to either driving or driven unit from vibration or thrust forces.

In package units with driver and blower mounted on a common baseplate, the two shafts will have been put in approximate alignment at the factory. However, baseplate deflections can occur during shipping and installation. A close coupling alignment should be obtained during leveling, so that only small final adjustments will need to be made after grouting. In a soleplate type installation, the separately mounted driver must be positioned, leveled and aligned as part of the installation procedure. Whether it is on soleplates or on its own base, shims of 1/16" to 1/8" (2-3 mm) thickness placed directly under the driver feet before setting will permit more accurate final alignment. Spacing between the two shaft ends as required by the coupling must also be established. If a motor is being used that has end-play in the shaft, be sure its rotor is located on magnetic center before setting this spacing.

When blower is driven through V-belts, the driver must be mounted on an adjustable base to permit tightening or removing the belts. In this case the driver shaft height is of no concern, but it must be parallel to the blower shaft and level. To position the driver properly, both sheaves need to be mounted on their shafts, and the shaft center distance must be known.

The blower sheave, usually the larger one in diameter, must be of the narrow hub type. Install it so that its inner hub face is not more than 1/4" (6 mm) away from the bearing housing end cover. The driver sheave should also be mounted as close to its bearing as possible. Now position the driver so that faces of the two sheaves are accurately in line, with the adjustable

base so located as to make 2/3 of its total movement available in the direction away from the blower. This positioning provides minimum belt wear and slip, and allows sufficient adjustment for installation and tightening of belts. Do not install belts until grouting has set and anchor bolts are tightened.

Blowers intended for driving by V-belts may be provided with an extended drive shaft and an additional outer bearing to handle the side pull of the drive. They may be recognized by the extended housing for the outer bearing. If necessary, these units may also be used for direct coupling to the driver. Blowers intended specifically for direct coupling have no outer bearing, and may be seriously damaged if used for belt drive. Consult your Sales Office for approval before belting these units.

**GROUTING** follows completion of leveling and preliminary alignment. Assuming the foundation has been properly cured, its top surface should first be roughened by chipping to remove glazed areas and oil or grease removed with a strong hot detergent or caustic solution.

Grouting serves not only to compensate for surface irregularities in the foundation and machine base but also to provide restraint against shifting. Anchor bolts are used for hold-down only. Therefore, the grout must be adequate thickness under the soleplate or base flange, must flow into anchor bolt sleeves and all interior cavities, and must have minimum shrinkage during the setting period. By virtue of the open frame

design, it is recommended that the bedplate be filled with concrete to a level equal to the top of the main channels. Special grouting materials designed to counteract shrinkage are commercially available, and are often preferred to cement. The manufacturer's instructions should be followed in using these materials. Care must be exercised when employing non-shrink additives with cement, as too much can be worse than none. Any gas forming or air-entraining additives should be avoided completely, since they tend to reduce grout strength.

Wait at least 24 hours before tightening anchor bolts or connecting any piping. When jack screws have been used for leveling, make sure the bottom of the leveling screw is treated according to grout manufacturer's instructions so that leveling screw can be backed off. Such points of concentrated loading are likely to wear during machine operation, resulting in loose anchor bolts. Final bolt tightening should be only enough to hold the machine firmly against the foundation and prevent vibration.

After all anchor bolts are secured, recheck the blower for twist and level. Working from the finished pad on top of the cylinder, make corrections to meet the requirements specified under **LEVELING** by shimming under the blower feet. Then rotate the drive shaft by hand to make sure both impellers turn freely at all positions.

**Figure 3 - Rotating and Discharge, Vertical and Horizontal RVS/VJ Blowers**

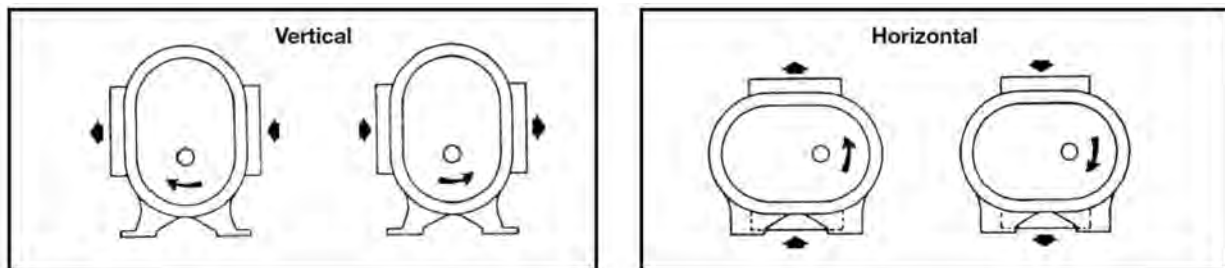

---

When the blower is direct coupled to its driver, final alignment of the two shafts should be accomplished next by adjusting the shims under the driver feet. This needs to be done with the greatest possible care. Even though a flexible coupling can accept some degree of misalignment, it should not be forced to compensate for careless workmanship. The flexing or sliding member in a coupling will transmit undesirable forces between the two shafts in proportion to the degree of misalignment, thus promoting vibration and unnecessary wear problems.

**MISALIGNMENT** can be of two basic types, offset and angular, but usually it will be a combination of both. For satisfactory coupling operation it is recommended that the following limits be used: maximum deviation in offset alignment not greater than .005" (.13 mm) total indicator reading on the coupling hubs; maximum deviation from parallel of the inside coupling faces not greater than .001" (.03 mm) when checked at six points. Where driver is a steam turbine, the final alignment should be made with the turbine at operating temperature in order to allow for shaft movement resulting from expansion.

A coupling that has been Factory installed as part of a pre-assembled package should receive the same final alignment check as outlined above. It will need to be disassembled by removing cover bolts, removing or drawing back the two cover halves, and removing the internal member. In some cases the latter item may have been packed separately for shipment. After necessary adjustments for alignment are completed, lubricate the coupling with grease as specified by its manufacturer and assemble.

A belt-driven installation should require no realignment if all items were correctly positioned and leveled before grouting. Belts may be installed now by adjusting driver position toward the blower sufficiently to permit belts to be laid in their sheave grooves easily. Do not pry or roll them into place. Before doing this, inspect all grooves for burrs, rough spots or oil that might shorten belt life. If equipment is not to be operated immediately, leave the belts slack.

Proper tensioning of the drive for operation should be done in accordance with manufacturer's recommendations, keeping in mind that excessive tension can seriously overload shaft bearings and also lead to premature drive failure. Under-tensioning can

produce slippage, with consequent loss of blower capacity in addition to belt damage.

Make sure at this point that driver rotation is correct to produce the blower shaft rotation indicated by an arrow near the shaft. Blowers are not reversible, hence drive shaft rotation and discharge angle location are predetermined in manufacturing assembly. Figure 4 illustrates the assembly options available by specification on original order, to meet piping and drive requirements.

**PIPING** must be clean, and should be sized so that air velocity in the line will not exceed 100 feet per second (30 m per second). When a blower is being operated at or near its maximum volume rating, the pipe size should not be smaller than the blower connections. Where possible, use long radius elbows to insure smooth flow. Design the piping layout so that no strains are placed on the blower, either from weight or expansion forces. This means providing adequate supports, anchors, and expansion joints or loops.

Installation of a spool-type rubber expansion joint near the blower inlet connection is recommended. A similar unit with control elements added to minimize piping vibrations may be required near the discharge. Use of **SNUBBERS** or **SILENCERS** in the inlet or discharge piping will be dependent on such factors as blower speed, operating pressure, length and kind of piping, and consideration of sound level requirements in the general surrounding area. For specific silencer recommendations refer to the nearest Sales Office.

Inlet piping should be completely free of valves or restrictions, but when a shut-off valve cannot be avoided, make sure a full size vacuum relief valve is installed near the blower inlet connection. See Figure 5. This will protect against an overload caused by accidental valve closing. Further protection can be provided by installation of a dependable pressure sensitive device with alarm or shutdown action.

During initial operation, install a temporary corrosion resistant screen at the compressor inlet connection. Screen should be made of 16 mesh (.020" diameter) wire backed with 2 mesh wire cloth. Backing cloth-wire diameter shall be a minimum of 0.063" diameter for 12" pipe, 0.080" diameter for 16" pipe, 0.105" diameter for 20" pipe, and 0.120" diameter for 24" pipe. For 30" and 36" pipe use 1 mesh backing cloth

with a minimum of .180" wire diameter for 36" pipe. The table below gives approximate screen pressure drop. A manometer connected to read pressure drop across the screen will indicate when it needs cleaning. Do not allow pressure drop to exceed 55 inches H<sub>2</sub>O. Clean and replace the screen until debris no longer appears. Do not leave it installed permanently, as the wire will eventually deteriorate and pieces may go into the blower causing serious damage. (Typically, screens are installed 1-2 days of operation.)

**Figure 4 - Installation of RVS/VJ Single Stage Water Sealed Vacuum Blower**

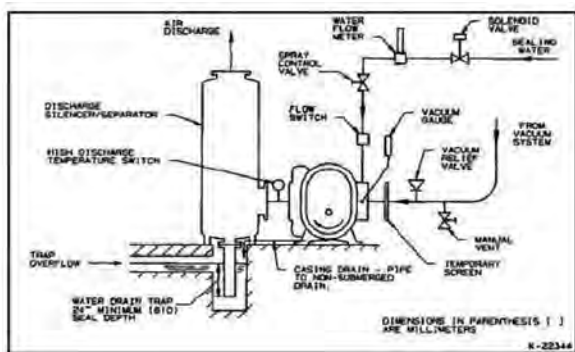

**Figure 5 - Installation of RVS/VJ Single Stage Water Sealed Vacuum Blower**

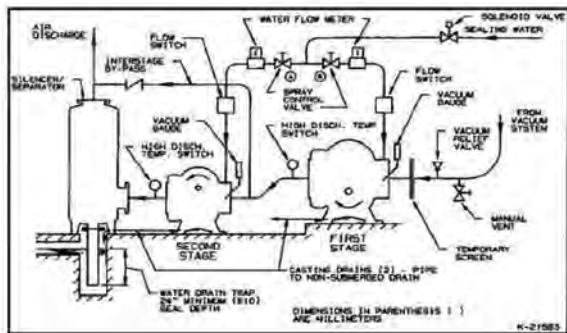

Blower inlet piping will be handling liquids in most cases, and any horizontal sections of pipe should be sloped toward the blower with a minimum fall of 1/4 inch per foot (20 mm per m) to provide drainage. This must be accomplished while still meeting the general requirement that all pipe angles must meet the pump connections accurately and squarely. Any springing or cramping of the pipe can distort the blower casing and cause impeller rubbing. It may even prevent operation, or result in a broken shaft. Piping should also be supported near the blower to reduce

**Approximate Screen Pressure Drop, Inches H<sub>2</sub>O  
(16 Mesh, 0.020" Wire Dia.)**

Flow (ACFM)	Pipe Diameter (Inches)						
	12"	16"	20"	24"	30"	36"	42"
2,500	3.0	1.1	0.3	.03	-	-	-
5,000	12.7	3.9	1.7	.08	-	-	-
10,000	-	15.5	6.4	3.0	1.3	-	-
15,000	-	-	14.4	7.2	2.8	1.4	-
20,000	-	-	-	12.7	5.1	2.4	1.4
30,000	-	-	-	-	11.4	5.5	3.0
45,000	-	-	-	-	-	12.3	7.0
60,000	-	-	-	-	-	-	12.5

dead weight strains. Installation of a flexible connector or expansion joint is advisable. If it is known that quantities of liquid in excess of the continuous sealing requirements (Table 1) will flow to a RVS/VJ vacuum blower, the excess should be withdrawn from the inlet piping by an efficient water separation and removal arrangement. Bear in mind that part of the sealing water must be supplied independently by controlled injection at the blower.

In some instances, two or more vacuum blowers may be installed to operate in parallel from a common inlet header. To prevent air back flow and damaging reversed rotation of an idle blower, the inlet line to each blower must be equipped with a check valve.

Discharge piping from the vacuum blower should terminate in a combination silencer and water separator installed as indicated in Figures 4 and 5. Locate the silencer as close to the blower as possible, and use piping as large as the blower connection. The water drain outlet at the bottom should go to a trap having sufficient seal depth to handle the low back pressure produced in the silencer and its discharge piping. A seal depth of 24 inches (610 mm) may be considered minimum. Since the blower is not intended to operate against any appreciable positive pressure, the silencer air discharge piping should be short.

Design of the discharge silencer drain trap represented in Figures 4 and 5 involves certain considerations for best performance. The water level in the trap must be self-sustaining. At blower start-up the trap will probably be blown dry, and it will remain in that condition if there is not sufficient water head to reform the seal. Excessive noise and water spray will result. Some spray may be present even under normal

conditions, hence it usually is desirable to provide a removable cover for the trap. In event several blower units discharge into a covered trench, the bottom must be sloped at least 1/8" per foot (20 mm per m) in the direction of water flow and should be contoured to minimize water splashing.

To supply a RVS/VJ blower with sealing water at a controlled flow rate, a spray nozzle is provided in the blower inlet, as indicated in Figures 4 and 5. A clean water supply at reasonable pressure must be piped to the spray nozzle or nozzles, as shown diagrammatically in Figure 6. The strainer is recommended to protect the flow meter and reduce chances of spray nozzle clogging. All piping must be protected against freezing.

If dirty water containing process stock is used for scaling, the valve full size by-pass piping around the flow meter is recommended. This arrangement will permit using the meter only during adjustment of water rates to the spray nozzles.

A water drain connection is provided in the bottom of the blower cylinder, and should be piped as directly as possible.

## V-Belt Drives

### Recommendations:

- **V-Belt Drive ONLY suitable for Opposite Gear End (OGE) Drive units. V-Belt Drive NOT suitable for Gear End (GE) Drive units.**
- Attempting to belt drive with a motor in excess of 200 HP will make it difficult to size a drive without exceeding the maximum shaft loads. To belt drive over 200 HP generally requires a jackshaft with pillow block bearings connected to the blower by a coupling.
- Use a minimum of 1.4 service factor on the drive horsepower.
- Vertical units must be driven with the motor on the inlet side. Horizontal units must be driven from the drive shaft side.
- Use molded notch belts, power band type where possible.
- The contact arc of the smaller sheave is not to be less than 170°.

Gear Diameter	Dimension "A" (Inches)		Maximum Allowable Shaft Load (Lb./In.)
	With Inboard Bearing	W/O Inboard Bearing	
10"	2.32	4	11,000
12"	2.55	4.09	15,000
14"	2.58	4.55	21,000
16"	N/A	4.97	40,500
18"	N/A	5.68	63,000
20"	N/A	6.05	70,000

$$\text{Belt Pull (Lbs.)} = (275,000 \times \text{Motor HP}) / (\text{Blower RPM} \times \text{Sheave Diameter})$$

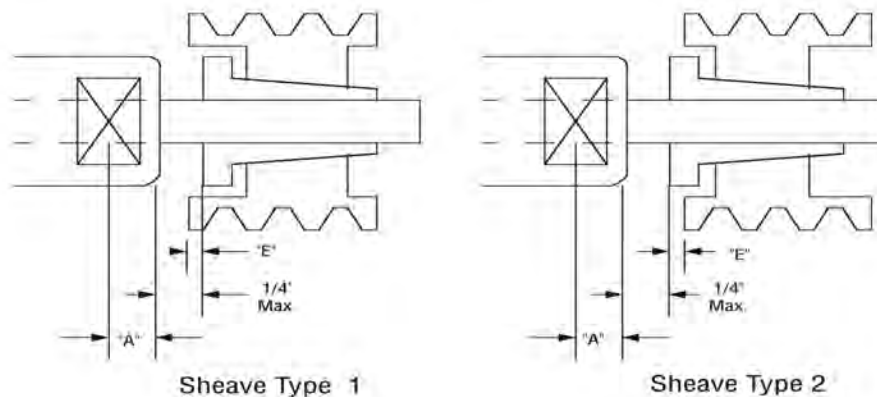

$$\text{Shaft Load (Lb.-In.)} = \text{Belt Pull} \times (\text{A} + 1/4" \text{ (+ or - E see below *)} + \text{Sheave width} / 2)$$

\* Subtract "E" if sheave type 1 is used, Add "E" if sheave type 2 is used.

## Lubrication

### A - SEPARATE OPPOSITE GEAR END RESERVOIRS

A simple and reliable splash lubrication system is employed in Roots® blowers. All friction parts - gears, bearings and shaft seals - are lubricated either by dipping directly into oil reservoirs or by receiving splash oil from other rotating parts. All reservoirs require the same grade of oil as specified in Table 3 for various ambient temperature ranges at the installation site. Reference to the appropriate assembly drawing for understanding of the following discussion.

**Table 3 - Air Blower Installation with Accessories**

Ambient Temperature	Viscosity Range, SSu at 100% °F (83°C)
Above 90°F (32°C)	1000-1200
32° to 90°F (0°-32°C)	700-1000
0° to 32°F (-18°-0°C)	500-700
Below 0°F (-18°C)	300-500

At the opposite gear end of the blower, the upper (or driven) shaft bearing is lubricated from its own oil reservoir, formed by the bearing carrier (6) and the deep blind end cover (5A). At a normal oil level, bearing rollers dip into the oil as they roll through the bottom of their raceway. The oil picked up is carried over the top by bearing rotation, and some of it transfers to the shaft behind the bearing to lubricate the dynamic lip-type inboard seal (27). A slight amount of oil may work through this seal, but it will be thrown off by the shaft slinger, and further prevented from reaching the air chamber by a labyrinth type seal where the shaft passes through the headpiece. The chamber between the two sealing points is vented to atmosphere and serves not only to drain any seal leakage but also to keep the lubrication system at atmospheric pressure.

At the lower (driving) shaft the arrangement is the same as described above when a short shaft for direct coupling is provided. Here an outboard shaft seal (23) is provided in the end cover (5). On V-belt driven blowers the drive shaft and bearing carrier (63) are extended and provided with an additional inboard bearing (60). This creates a larger reservoir requiring about three times as much oil. Lubrication is the same as for the shorter shaft, except that two protruding screws (96) are provided to insure adequate splash oil for bearing (60).

At the gear end of the blower the bearings, seals and timing gears are enclosed by a gearbox containing a double (primary and secondary) oil sump arrangement. In a vertical style blower the secondary sump is formed of sheet steel and contoured around the bottom half of the lower gear. It is fed with oil at a controlled rate from the surrounding primary sump in the gearbox itself, through a metering orifice in the secondary wall. The lower gear teeth pick up oil and carry it to the meshing point with the upper gear, from where it is splashed onto oil control shields with leaders that direct the oil to the two bearings. A dam at each bearing maintains the desired oil level there, with excess overflowing into the gearbox primary sump. Inboard sealing of the shafts is the same as at the drive end. In a horizontal style blower the gear end lubrication arrangement is identical, except that a secondary sump is formed around each gear and the total oil capacity is more than doubled.

**Note** - A good grade of industrial type non-detergent, anti-foaming oil should be used when the average of blower inlet and discharge temperature is 125°F (52°C) or lower. Oil should be changed after the first 100 hours of operation. After initial oil change, normal oil change periods under these conditions may be considered as 2000 operating hours. At higher temperatures these oils may turn black and leave carbon deposits. For average temperatures above 125°F (52°C) it is recommended that oil with an efficient oxidation inhibitor be used, and that change interval be reduced. Shell TELLUS is a suitable oil type with the required characteristics, and equivalent oils from other suppliers are assumed to be comparable in performance. Suggested oil change periods for the higher operating temperatures are as follows:

Average Temp. °F (C°)	Operating Hrs.
Below 150 (65)	1000
151-160 (66-71)	500

Above average temperature of 180°F, use of synthetic oil like ROOTS Syn Ilm ST Synthetic Oil is specified.

On the gearbox and the two opposite gear end bearings sumps, oil levels are indicated in sight windows. All three sight windows are completely unobstructed circular discs, and the oil level should always be in view.

Approximate capacities in gallons or fluid ounces for the three sump locations are given in Table 4 as a guide. Actual filling requirements may vary slightly from the listed figures. Select a good industrial grade of oil per Table 3 for the existing ambient temperature conditions.

Filling of the oil sump must be performed with the blower not operating, so that correct levels may be established. At the gearbox, remove vent plug (37) in the top and pour in slightly less oil than indicated in Table 4 for the blower size concerned, or until the oil rises to the center of the sight glass. Wait several minutes for the levels to equalize between the primary and secondary sumps, then add more oil if needed, or drain excess at plug (67).

**Figure 6**

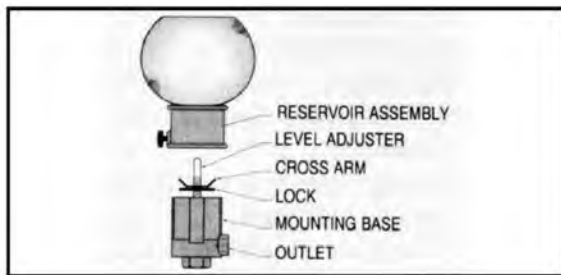

The opposite gear end sumps use constant level oilers. To fill the sumps, remove the top glass reservoir. Fill it with oil and place it on its holder and let the bottle empty to fill the sump. To obtain proper oil level in the sump, that is to the center of the sight glass (90), pull out level adjuster "A" (see fig.6) and raise or lower cross-arm "B" as needed, secure "B" with lock

"C" and drop assembly back into lower reservoir and replace bottle. Note - Raising "B" raises oil level and lowering "B" lowers oil level.

During operation the sump levels can be expected to fluctuate. At the gearbox sight window the level will rise as a result of oil being thrown out of the secondary sump (oil pan) into the primary sump. A satisfactory oil level is assured as long as it is visible in the window. A blower should not be operated when the oil is either above or below the circle on the sight window.

Oil levels at the opposite gear end will fall slightly during operation because of the apparent "loss" carried in the bearings and on the shafts. To be satisfactory, the level must be visible in the sight glass.

During the first week of blower operation, check the oil level daily and watch for leaks. Replenish oil as necessary. Thereafter, an occasional check should be sufficient. Drain plugs (67 and 88) are provided at the bottom of gearbox and bearing sumps.

**Table 4 - Oil Sump Capacities**

Blower Frame Size	Gearbox - gallons (liters)		Opposite Gear End Bearings - fluid oz. (liters)		
	Vertical	Horizontal	Driven Shaft	Drive Shaft Coupled	Drive Shaft Belted
1000	3/4 (2.8)	2 (7.6)	4 (.12)	4 (.12)	12 (.36)
1200	1-1/2 (5.7)	3-1/2 (13)	5 (.15)	5 (.15)	16 (.47)
1400	1-3/4 (6.6)	4 (15)	8 (.24)	8 (.24)	28 (.83)
1600	2-1/2 (9.5)	5-3/4 (22)	9 (.27)	9 (.27)	
1800	3 (11)	7-1/2 (28)	16 (.47)	16 (.47)	
2000	4 (15)	9-3/4 (37)	19 (.56)	19 (.56)	

## B - COMMON OPPOSITE GEAR END RESERVOIRS

Some blowers are equipped with a common reservoir on the opposite gear end. The small reservoirs are replaced with a large cover similar to that covering the gear end. The oil is transmitted to the bearings by use of a slinger plate which dips into the oil. The oil is then captured and directed to the bearings by oil control shields. Reference to the sectional drawings at the back of this manual will help in understanding this system.

**Table 5 - Common O.G.E. Sump Capacity**

Blower Frame Size	Gearbox Gallon/liters		O.G.E. Gallon/liters	
	Vertical	Horizontal	Vertical	Horizontal
1000	7/8 (3.3)	2 (7.6)	5/8 (2.4)	1-1/4 (4.7)
1200	1-1/2 (5.7)	3-1/2 (13)	1-1/4 (4.7)	1-3/4 (6.6)
1400	1-3/4 (6.6)	4 (15)	1-1/2 (5.7)	2-1/4 (8.5)
1600	2-1/2 (9.5)	5-3/4 (22)	2 (7.6)	3-1/4 (12)
1800	3 (11)	7-1/2 (28)	2-1/2 (9.5)	4 (15)
2000	4 (15)	9-3/4 (37)	3 (11)	5-1/4 (20)

The lubrication of the gear end of the blower remains as described earlier.

Approximate opposite gear end oil sump capacity is shown in Table 5.

Some blowers utilizing the common O.G.E. reservoir are supplied with oil level switches. The recommended procedure for setting these switches is as follows:

- Prior to starting the blower:
  - Add oil to the reservoirs until the level is in the center of the bulls-eye sightglasses.
  - Disconnect the level switch from the blower shut-down system.
  - Position the level switch slightly above the oil level so the switch is not as yet reset.
- Start the blower and allow the oil temperature to stabilize (approximately 1/2 hour running time).
- Slowly begin to lower the position of the oil level switch, and mark the height at which it resets.
- If only an oil level shutdown is to be used,

continue to lower the switch until it is 3/4" below the position where the switch reset, and lock it in place.

- If an oil level alarm is to be used as well as a shut down, lower the switch 1/2" below the point where the alarm switch reset, and lock the switch in place.

Lip seal oil leakage - Some oil seal leakage will occur at the drive shaft seal and the headplate seals since an oil film under the lip is required for proper operation. Periodically, the leaked oil should be wiped off from the blower as well as base plate surfaces, since even a small amount of leaked oil spreads over a larger area making the leakage look worse than actual.

## Operation

Before starting the blower under power for the first time, recheck the installation thoroughly to reduce the likelihood of troubles. Use the following procedure check list as a guide, but also consider any other special conditions in the installation.

Be certain no bolts, rags or dirt have been left in the blower air chamber.

Be certain that inlet piping is free of debris. Use of the temporary protective screen at the blower inlet as described under **INSTALLATION** is strongly recommended during early operation.

Check blower leveling, drive alignment, belt tension and tightness of all mounting bolts if installation is not recent.

Turn drive shaft slowly by hand to make sure impellers will rotate without bumping or rubbing at any point.

Check the blower lubrication system. Oil level should be at the center of the sight glasses.

Make sure driver (and gear unit if supplied) are properly lubricated. Check that power is available and that all electrical overload and safety controls are installed, connected and in operating condition.

Open any valve in the inlet piping, and vent this line to atmosphere if possible. Initial operating checks should be carried out under "no load" conditions.

Bump blower a few revolutions with driver to check and see that both units coast freely to a stop.



---

Turn off sealing water supply by opening the manual shut-off valve (C in Figure 6). Water will not flow to the spray nozzle yet since solenoid operated valve (SV) is held closed until the motor starter is engaged.

Set valving at the water flow meter (Figure 6) so meter is in the line, with the by-pass pipe loop closed. Set spray control valve (B) about 75% open as a preliminary adjustment. In a two-stage installation, also set the corresponding valve (A) at the second blower in the same manner.

With the preceding check and adjustments completed satisfactorily, the vacuum blower should be ready for an operating test. The following procedure is recommended:

Start the blower, let it accelerate to full speed, then shut off. Listen for knocking sounds, both with power on and as the unit slows down. Also, observe the sealing water flow meter. A flow indication verifies that solenoid valve (SV) has opened properly.

If no problems have appeared, restart the the blower and let it operate for 5 to 10 minutes under no-load conditions. Adjust spray control valve (B) so that the water flow meter flow indicator equals the Recommended Max. in Table 1. For a two-stage installation, close valve (B) on the first stage and adjust valve (A) on the second stage so that flow meter indicates one third of the allowable total flow rate. Then open valve (B) until flow meter reads the correct total water rate. This adjustment is semi-permanent and the two control valves should be locked by removing their wheels or by other suitable methods. Valve (C) then serves as the master valve.

Also during this period, check the cylinder and headplates by feeling for hot spots indicating impeller rubs. Continue to be alert for unusual noises and changes in vibration. Check oil levels in the sight windows at the sumps and verify several times that the flow rate at the sealing water meter remains reasonably constant. Shut down unit and note whether water meter shows no flow, indicating the solenoid water valve (SV) has closed properly. Check that seal water is draining from the cylinder through the pipe line connected at the bottom, if not, make sure this drain is not clogged. Recheck all surfaces for hot spots.

If all conditions are acceptable, restart the vacuum blower and observe for at least one hour. During this

period the normal vacuum working load should be applied on the blower inlet gradually. As this is done, it is important to make sure the inlet vacuum level and the temperature rise do not exceed the allowable figures listed in Table 1. Good mercury manometers should be installed at the inlet and discharge of the blower to check pressure conditions. On two stage units they should be installed for both blowers. Operating temperatures under average conditions will be low enough that a sufficient check can be made by feeling the cylinder. However, if the cylinder temperature runs uncomfortably hot, it may be advisable to install inlet and discharge thermometers for more accurate information. As the run progresses continue to check for noises and vibration changes, observe oil level at the sumps and watch the water flow rate. Also, note the behaviour of the discharge silencer drain trap. If any trouble appears, refer to the TROUBLESHOOTING CHECK LIST for suggested remedies.

The vacuum blower should now be ready for continuous duty under full working load. During the first several days make periodic checks to be sure all conditions remain reasonably steady and within specified limits. These checks can be especially important if the unit is part of a process system in which conditions may vary widely. If such variations can put an excessive vacuum load on the blower, overloading can often be avoided by installation of a pilot operated vacuum near the blower inlet. For further protection, a dependable pressure sensitive device can be installed to provide alarm and/or shutdown action.

At the first opportunity, stop the blower and clean the temporary protective pump inlet screen. Depending on the amount and type of debris found, judgment can be made as to how long the screen should remain in place. Unfavourable conditions may lead to repeated and frequent clogging or loading. Installation of manometers in such cases will reveal the need for cleaning by indicating an increase in pressure drop through the screen. During this shut-down period verify leveling, anchor bolt tightness, alignment of shaft coupling, or tension of drive belts.

---

## OPTIMIZATION OF WATER INJECTION FLOW

The amount of water injected into the inlet of water sealed vacuum pumps to seal between internal clearances and to control the temperature rise of the gas across the vacuum pump is by design 1 GPM (gallon per minute) per inch of gear diameter. I.E. On a 14 inch gear diameter vacuum pump normal water injection would be 14 GPM.

On two stage vacuum pumps the water injection is dependent on the first stage gear diameter but is split 2/3 to the first stage and 1/3 to the second stage. I.E. With a 14" gear diameter first stage and a 12" diameter second stage, 9.5GPM would be supplied to the first stage and 4.5 GPM to the second stage.

This amount of water has been found to be the maximum water flow requirement needed to deliver the maximum gas capacity.

In actual application it may be possible to reduce the amount of water injected and still achieve the vacuum pump maximum gas capacity or the maximum gas capacity required by the system.

Optimizing the water flow will reduce the water usage, reduce vacuum pump erosion, and slightly reduce the vacuum pump power consumption.

### SINGLE STAGE WATER INJECTION OPTIMIZATION:

CAUTION: WHEN REDUCING WATER FLOW DO NOT EXCEED 60 DEGREES FARENHEIT GAS TEMPERATURE RISE ACROSS THE VACUUM PUMP

If the vacuum pump is put in a system where the vacuum level and gas flow are constant, reduce the water flow to the vacuum pump inlet gradually until the inlet vacuum level begins to fall. Then increase the water flow until the vacuum is back to its normal level. This will be the optimum water injection flow for the system.

If the vacuum pump is in a vacuum swing application where there is a defined time set to pull the system down to a required vacuum level, the same procedure applies but the water flow reduction must be accomplished in steps and the maximum vacuum level achieved during the swing cycle observed.

If the system does not require the amount of vacuum that is being achieved, the water flow may be reduced

further until the actual vacuum level required by the system is achieved. The only limit to the amount of water flow reduction is the temperature rise across the vacuum pump as stated in the CAUTION above. When checking for temperature rise do not depend entirely on temperature gauges, feel the discharge area of the vacuum pump cylinder to make certain the casing temperature is uniform all around.

### MULTI-STAGE WATER INJECTION OPTIMIZATION:

CAUTION: WHEN REDUCING WATER FLOW DO NOT EXCEED 60 DEGREES FARENHEIT GAS TEMPERATURE RISE ACROSS ANY STAGE OF THE VACUUM PUMP

The water flow can be optimized in the same basic manner as on a single stage vacuum.

On a two-stage vacuum pump begin by gradually reducing the water flow to the second stage. It may be possible to shut the second stage water off completely and lose very little gas flow capacity or vacuum level. When the water flow to the second stage has been optimized, reduce the water flow to the first stage in the same manner as described under single stage optimization.

Three stage water flow optimization is accomplished in the same manner. Begin at the third stage, then proceed to the second stage, and finally to the first stage.

### COMMENTS IN INJECTION WATER QUALITY

In cases where water is injected into a Roots positive displacement blower or vacuum pump for sealing or cooling purposes, water quality is always a concern. There are many variables in the nature of water which could cause it to be corrosive, erosive or most commonly, cause scaling or plating of blower internal parts.

The interaction of different water contaminants is too varied to specify maximum acceptable values for any given contaminant with certainty. (For instance, calcium is a major scale producer, but when found in initially acidic water, it may not cause scaling. Dissolved solids may reduce or increase the corrosive properties of water depending on the concentration and type of ions involved.) For this reason water which is within the bounds of the recommendations below will not guarantee complete elimination of corrosion,

---

erosion, or scaling but should keep their effects to a manageable level.

1. Water pH for 6 to 9.
2. Maximum hardness 50 PPM.
3. A Langlier Stability Index of -0.15 to +0.15 at blower discharge temperature. The index is only an indication of the water to scale (positive value) or corrode (negative value).
4. Suspended particles greater than 10 microns should be removed by filtration.

It is strongly recommended that the water to be injected be analyzed. Water treatment companies can perform this service, and can recommend treatment to reduce or eliminate the corrosive or scaling nature of the water.

Some treatments of water in the amounts required be prohibitively expensive, and in some cases it may be decided to use water having properties greater than or less than those shown above. This will seldom cause immediate problems but may create a need for more frequent maintenance.

In any case, the blower discharge piping should initially be removed at regular intervals to determine if any maintenance is required and to establish a maintenance schedule.

### **SCALE BUILD-UP**

A basic principle of the Roots RVS/VJ unit is that there is no internal contact of moving parts. To satisfy this concept and still maintain maximum pumping efficiency, there must be small but definite clearances between the impellers and between impellers and case. Any scale build-up due to mineral deposits from the water or process residue, which tends to close these clearances, is intolerable. Loss of clearances will cause the impellers to rub the case and each other, which may cause the unit to stick while in operation or to freeze when shut down.

There are two methods of preventing scale build-up. One method is to use de-mineralized water for sealing and to filter any process residue ahead of the unit. The other method is to de-scale the unit at regular intervals, such as weekend shut-downs. The latter method is simpler and more economical, unless shut-down periods are infrequent.

It is recommended that a sample of the build-up material be sent to the scale removal supplier for analysis so the proper agent can be selected for the removal. Scale deposits in different processes and localities may require variations in concentration or type of removal agent.

When a vacuum blower is taken out of service, it may require internal protection against rusting or corrosion. The need for protection must be a matter of judgment based on existing conditions as well as length of downtime. Under favorable conditions, protection probably will not be needed if shut-down is not longer than one day. Under conditions likely to produce rapid corrosion the blower should be protected immediately. Following is a suggested procedure.

Remove the vacuum load from the blower and vent the inlet to atmosphere. With the sealing water shut off, run the blower until the interior surfaces are judged to be dry. Remove inlet and discharge piping at the blower connections and inspect the interior. If any moisture is present, run the blower again until drying is completed. Coarse screens should be placed over both connections to avoid damage or personal injury.

Now coat all finished surfaces of cylinder, headplate and impellers with a protective compound as described in the INSTALLATION section under "Protection."

### **Safety Precautions**

For equipment covered specifically or indirectly in this instruction book, it is important that all personnel observe safety precautions to minimize the chances of injury. Among many considerations, the following should particularly be noted:

- Blower casing and associated piping or accessories may become hot enough to cause major skin burns on contact.
- Internal and external rotating parts of the blower and driving equipment can produce serious physical injuries. Do not reach into any opening in the blower while it is operating, or while subject to accidental starting. Cover external moving parts with adequate guards.
- Disconnect power before doing any work, and avoid by-passing or rendering inoperative any safety or protective devices.

- If blower is operated with piping disconnected, place a strong coarse screen over the inlet and avoid standing in the discharge air stream.
- Stay clear of open inlet piping (suction area) of pressure blowers, and the open discharge blast from vacuum blowers.
- Stay clear of the blast from pressure relief valves and the suction area of vacuum relief valves.
- Avoid extended exposure in close proximity to machinery which exceeds safe noise levels.
- Use proper care and good procedures in handling, lifting, installing, operating and maintaining the equipment.
- Casing pressure must not exceed 25 PSI (172 kPa) gauge. Do not pressurize vented cavities from an external source, nor restrict the vents.
- Do not use air blowers on explosive or hazardous gases.
- Other potential hazards to safety may also be associated with operation of this equipment. All personnel working in or passing through the area should be warned by signs and trained to exercise adequate general safety precautions.

## Preventative Maintenance

### 1. Daily

A. Record the following:

- 1) Lube oil pressure (if applicable).
- 2) Lube oil temperature (if applicable).
- 3) Blower inlet temperature.
- 4) Blower inlet pressure.
- 5) Blower discharge temperature.
- 6) Blower discharge pressure or differential pressure.
- 7) Motor amperage.
- 8) Motor voltage, if available.
- 9) Motor stator temperature, if available.
- 10) Motor bearing temperature, if available.

B. Observe any abnormalities, i.e. burned paint, unusual noises, vibration, strange odours, oil leaks, etc.

C. Review log sheets to determine if there are any changes from previous readings. (It is very important to look for any changes or trends which might indicate pending problems).

D. Check oil levels.

E. Record hour meter readings.

### 2. Monthly

A. Record bearing housing vibration levels at each bearing in the horizontal, vertical, and axial planes. Use velocity (in./sec.) measurements and note any changes from previous readings. Take a complete vibration signature (amplitude versus frequency) if any trends are noted. (It may be helpful to keep a chart on monthly readings.)

### 3. Quarterly

A. Sample lube oil or change.

B. Change oil if the following values are exceeded:

- 1) Water 100 PPM maximum.
- 2) Metals 200 PPM maximum.
- 3) Acid 5.0 to 7.5 Mg/KOH/g maximum.

C. Increase frequency of sampling if any of the above values show about 20 to 25% increase over the last sample.

D. Flush all oil reservoirs before filling with clean oil.

### 4. Annually

A. Remove an inlet expansion joint, inspect impellers, measure impeller clearances and note wear patterns.

B. Check coupling alignment, inspect coupling for wear, and repack with fresh grease.

C. Inspect oil cooler tubes, as applicable.

D. Check all protective switches for proper set points and operation.

E. Check V-belt drive condition and tension.

5. A Preventative Maintenance Schedule should be established for driver(s) and all accessories in accordance with the applicable manufacturer's recommendation.

## Troubleshooting Checklist

Trouble	Item	Possible Cause	Remedy
No Flow	1	Speed too low	Check by tachometer and compare with speed on Roots Order Acknowledgment
	2	Wrong Rotation	Compare actual rotation with Figure 3 or 4. Change driver if wrong.
	3	Obstruction in piping	Check piping, valves, silencer, to assure open flow path
Low Capacity	4	Speed too low	See item 1. If belt drive, check for slippage and readjust tension.
	5	Excessive pressure rise	Check inlet vacuum and discharge pressure, and compare these figures with specified operating conditions on order.
	6	Obstruction in piping	See item 3.
	7	Excessive slip	Check inside of casing for worn or eroded surfaces causing excessive clearances
Excessive Power	8	Speed too high	Check speed and compare with Roots Order Acknowledgement.
	9	Excessive pressure rise	See item 5.
	10	Impellers rubbing	Inspect outside of cylinder for high temperature areas, then check for impeller contact at these points. Correct blower mounting, drive alignment.
Overheating of Bearings of Gears	11	Inadequate lubrication	Check oil sump levels in gearhouse and lube system pressure.
	12	Excessive lubrication	Check oil level and verify pressure. If incorrect, drain and refill with clean oil or oil of recommended grade.
	13	Excessive pressure rise	See item 5.
	14	Coupling misalignment	Check carefully. Realign if questionable.
	15	Excessive belt tension	Readjust for correct tension
Vibration - Refer to "Rotary Lobe Blower Vibrations"	16	Misalignment	See item 14.
	17	Impellers rubbing	See item 10.
	18	Worn bearings/gears	Check gear backlash and condition of bearings, and replace as indicated.
	19	Unbalanced or rubbing impellers	Scale or process material may build up on casing and impellers, or inside impellers. Remove build-up to restore original clearances and impeller balance.
	20	Driver or blower loose	Tighten mounting bolts securely.
	21	Piping resonances	Determine whether standing wave pressure pulsations are present in the piping. Refer to Sales Office

## Rotary Lobe Blower Vibrations

The general vibration severity charts derived from Rathbone vibration severity charts provide guidelines for machines basically having mass unbalance- turbo machinery, electric motors, etc. The German specification VDI 2056 - Criteria for Assessing Mechanical Vibrations of Machines - provides vibration guide lines for machines with rotating masses (turbo machinery) and machines having mass effects which cannot be balanced (reciprocating machines), but does not specifically address rotary lobe blowers (also known as ROOTS Blowers) with inherent fluctuating dynamic bearing loads and torques.

API Standard 619, Rotary Type Positive Displacement Compressors for General Refinery Services, limits the vibration level to 0.1 in/sec peak, which is quite ambitious.

Based on experience, practical acceptable vibration levels lie somewhere between API 619 requirement and VDI 2056 allowance for group D reciprocating machines.

Elements Generating Vibrations in Rotary Lobe Blower:

1. Blower inherent characteristic -
  - a. Impacting bearing loads excite component/system natural frequencies.
  - b. Pressure pulsations set up vibrations at four times the running speed.
2. Rotary lobe blowers use very close clearances between the impellers and the housing. The impeller contact will setup vibrations as follows:
  - a. Impeller to impeller frontal lobe contact - if contact is between only one set of lobes, the vibration frequency will be 1XRPM, if both sets of lobes contact, the vibration frequency will be 2X RPM.
  - b. Impeller to cylinder contact - the vibration frequency will depend on the number of impeller tips contacting the cylinder which could range from one to four times the RPM.
  - c. Impeller to head plate contact - the vibration frequency will be erratic and unsteady.

3. Damaged gears will generate vibrations at mesh frequency, number of teeth times RPM.
4. Damaged bearings will generate vibrations at ball pass frequency, fundamental train frequency and ball spin frequency.
5. Rotor unbalance and bent shaft will generate vibrations at 1XRPM.
6. Blower/driver coupling misalignment will generate vibrations at 1XRPM and 2XRPM.
7. Acoustic resonance in the blower inlet/discharge piping will generate vibrations at 4XRPM.
8. Operation of rotary lobe blower at or near system tor-sionals may cause impeller lobe contact and increases vibrations.
9. External piping if not properly isolated will transmit vibrations into the blower.
10. Foundation design and method of mounting has considerable effect on blower vibrations.

### Vibration Criteria:

1. Units of measurement: Rotary lobe blower vibrations are measured in inches/sec. Measurements of spike energy is not recommended for judging blower condition because the rotary lobe blower has inherent impacting bearing loads.
2. Measurement location: Vibrations should be measured at the bearing locations on the housing.

The following table provides an appropriate assessment guideline for rotary lobe blowers rigidly mounted on the stiff foundations.

Unfiltered Vibrations (in/sec peak)	Assessment
>0.62 thru 1.0	Satisfactory
>1.0	Review Required

If the blower is operating at "review required" levels then the installation must be fully evaluated to determine the source or cause of vibration and the cause shall be corrected.

In general, blower vibration levels should be monitored on a regular basis and the vibration trend observed for progressive or sudden change in level. If such

a change occurs, the cause should be determined through spectral analysis.

The blower vibrations will be transmitted into the motor, speed reducer etc. and more so if they are mounted on the common blower baseplate. Allowable vibration levels into these accessories should be obtained from the vendors.

## Maintenance/Replacements

A good program of inspection and maintenance servicing, if followed consistently, is the most reliable means of preventing costly repairs to a blower. A simple record of procedures and dates will help maintain this work on a regular schedule. Basic requirements are lubrication and cleaning, along with periodic checking for increased vibration and hot spots on the cylinder. Inlet and discharge pressures and temperatures should be observed frequently, to minimize the chances for trouble resulting from blower ratings being exceeded. Above all, the unit must be operated within its specifications.

In a blower properly installed and operated, there is no moving contact between the two impellers, or between the impellers and cylinder or headplates. Wear is then confined to the timing gears, the bearings which support and locate the shafts, and shaft seals. All are lubricated, and wear should be normal if they are always supplied with clean, high grade lubricating oil. Shaft seals, weather lip type or rotating mechanical type, are subject to deterioration as well as wear. They may require replacement at varying periods. O-rings should be replaced at each disassembly.

If trouble should occur during operation, and its cause cannot be readily determined, consult the **TROUBLESHOOTING CHECKLIST**. Repairs not covered in this manual are considered beyond the scope of maintenance, and should be referred to Roots. See listing on the last page. Warranty failures should not be repaired at all, unless specific approval has been obtained from Roots before starting the work. Unauthorized disassembly within the warranty period may void the warranty.

Where repairs involve parts replacement, it is recommended that Factory Parts be used to insure fit and suitability. Delay in making such repairs can be reduced by having spare parts on hand.

## Troubleshooting & Repairs

### Repair Kit Information for RVS/VJ Splash Lube Blowers 40" - 20"

REF.	QTY.	PART DESCRIPTIONS
17	1	SHIM SET
18	1	GASKET
19	2	GASKET SUMP (P/L)
20	4	O-RING B/C (PL)
23	1	SEAL DR. SHAFT
24	2	LOCKNUT-BRG.
25	2	LOCKWASHER-BRG.
27	4	SEAL-HDPLT
31	4	BEARINGS
60	1	BEARINGS*
61	2	O-RING
81	2	GASKETS
-	1 Set	GEAR SCREWS**

\*V-Belt kits only \*\*12" kits and above

### Repair Kit Part Numbers

SIZE	REPAIR KIT NOS. (CPLG DRIVE)	REPAIR KIT NO. (V-BELT DRIVE)
10"	RL10AC900	RK10AVB00
12"	RL12AC900	RK12AVB00
14"	RL14AC900	RK14AVB00
16"	RL16AC900	
18"	RL18AC900	
20" (22 PSL)	RL20AC900	
20" (40 PSL)	RL20ACP0040	

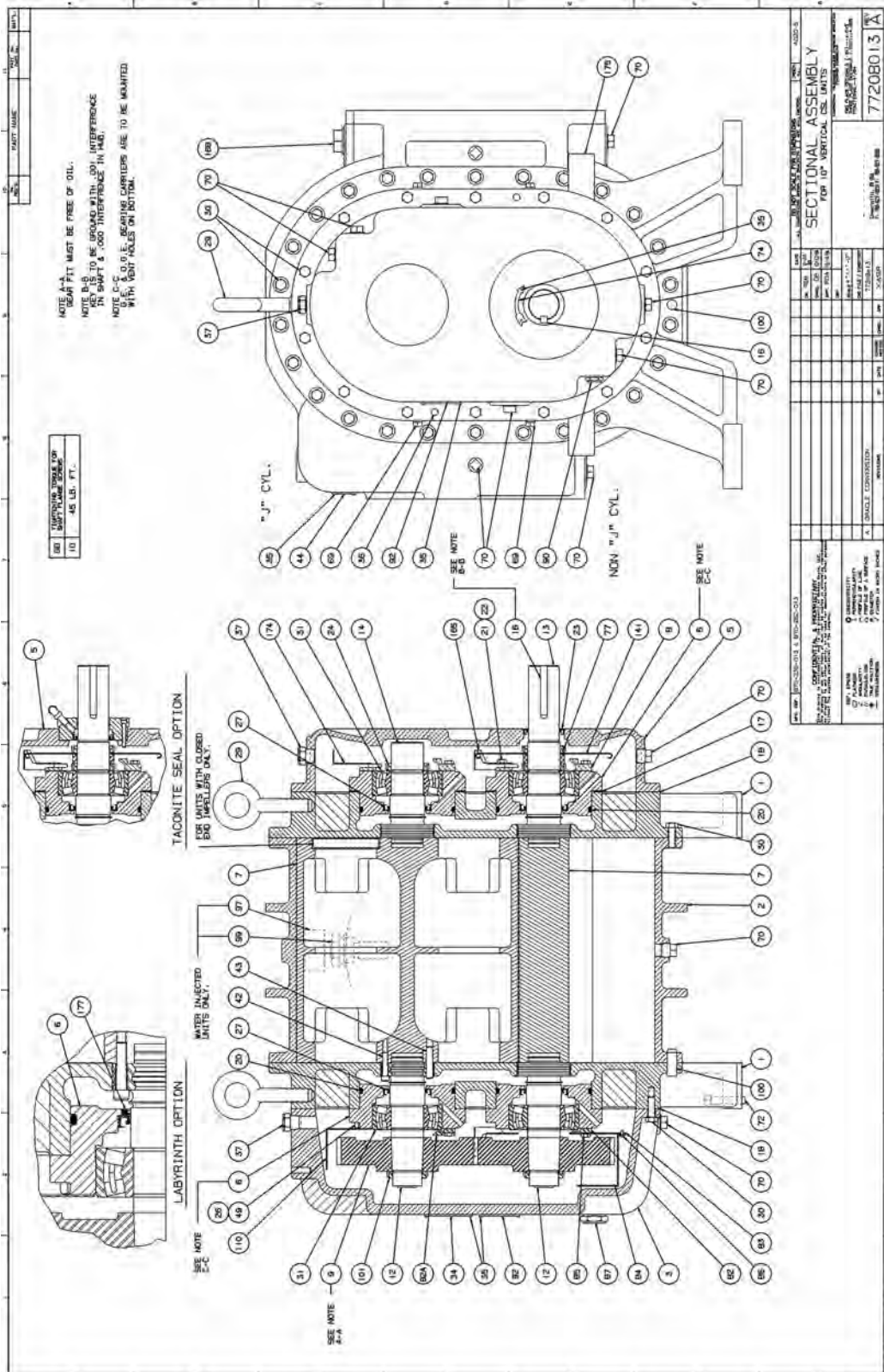



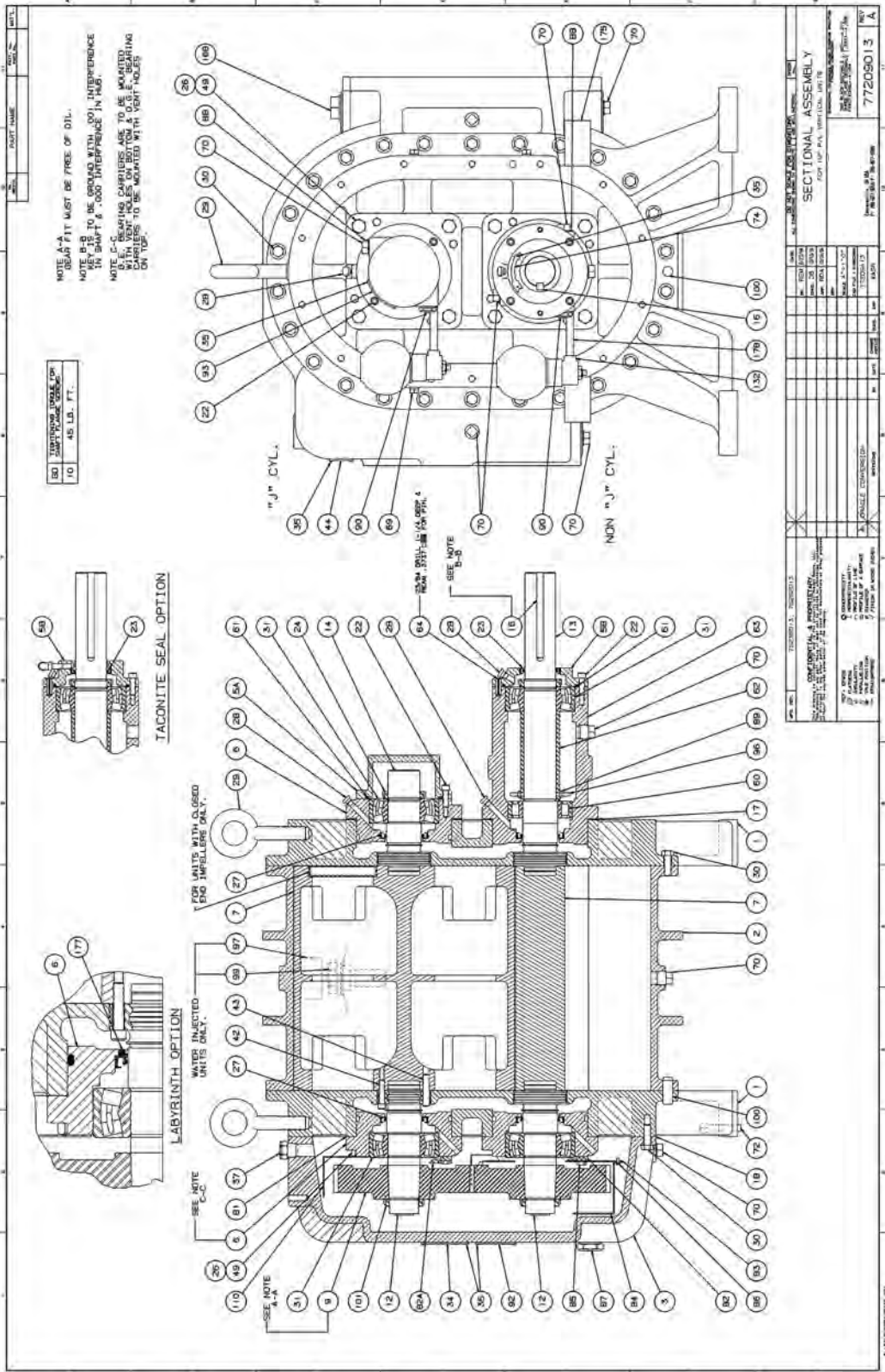

NOTE: SEAL FIT MUST BE FREE OF OIL.  
 NOTE: B-B TO BE GRIND WITH 0.001 INTERFERENCE  
 IN DIA. & 0.005 INTERFERENCE IN HGT.  
 NOTE: C-BEARING CARRIERS ARE TO BE MOUNTED  
 ON THE BOTTOM OF THE SEALS. SEALS  
 CARRIERS TO BE MOUNTED WITH VENT HOLES  
 ON TOP.

80 TACONITE SEAL FOR  
 10 45 LB. FT.

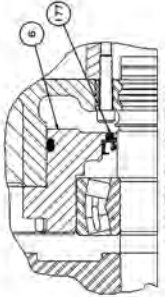
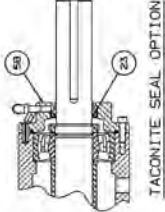

FOR UNITS WITH OLEO  
 END IMPELLERS ONLY.

WATER INJECTED  
 UNITS ONLY.

SEE NOTE  
 E-C

SEE NOTE  
 A

SEE NOTE  
 B-B

SECTIONAL ASSEMBLY		FOR THE P.A.V. VERTICAL UNIT	
REV.	DATE	BY	CHKD.
1			
2			
3			
4			
5			
6			
7			
8			
9			
10			
11			
12			
13			
14			
15			
16			
17			
18			
19			
20			
21			
22			
23			
24			
25			
26			
27			
28			
29			
30			
31			
32			
33			
34			
35			
36			
37			
38			
39			
40			
41			
42			
43			
44			
45			
46			
47			
48			
49			
50			
51			
52			
53			
54			
55			
56			
57			
58			
59			
60			
61			
62			
63			
64			
65			
66			
67			
68			
69			
70			
71			
72			
73			
74			
75			
76			
77			
78			
79			
80			
81			
82			
83			
84			
85			
86			
87			
88			
89			
90			
91			
92			
93			
94			
95			
96			
97			
98			
99			
100			
101			
102			
103			
104			
105			
106			
107			
108			
109			
110			
111			
112			
113			
114			
115			
116			
117			
118			
119			
120			
121			
122			
123			
124			
125			
126			
127			
128			
129			
130			
131			
132			
133			
134			
135			
136			
137			
138			
139			
140			
141			
142			
143			
144			
145			
146			
147			
148			
149			
150			
151			
152			
153			
154			
155			
156			
157			
158			
159			
160			
161			
162			
163			
164			
165			
166			
167			
168			
169			
170			
171			
172			
173			
174			
175			
176			
177			
178			
179			
180			
181			
182			
183			
184			
185			
186			
187			
188			
189			
190			
191			
192			
193			
194			
195			
196			
197			
198			
199			
200			

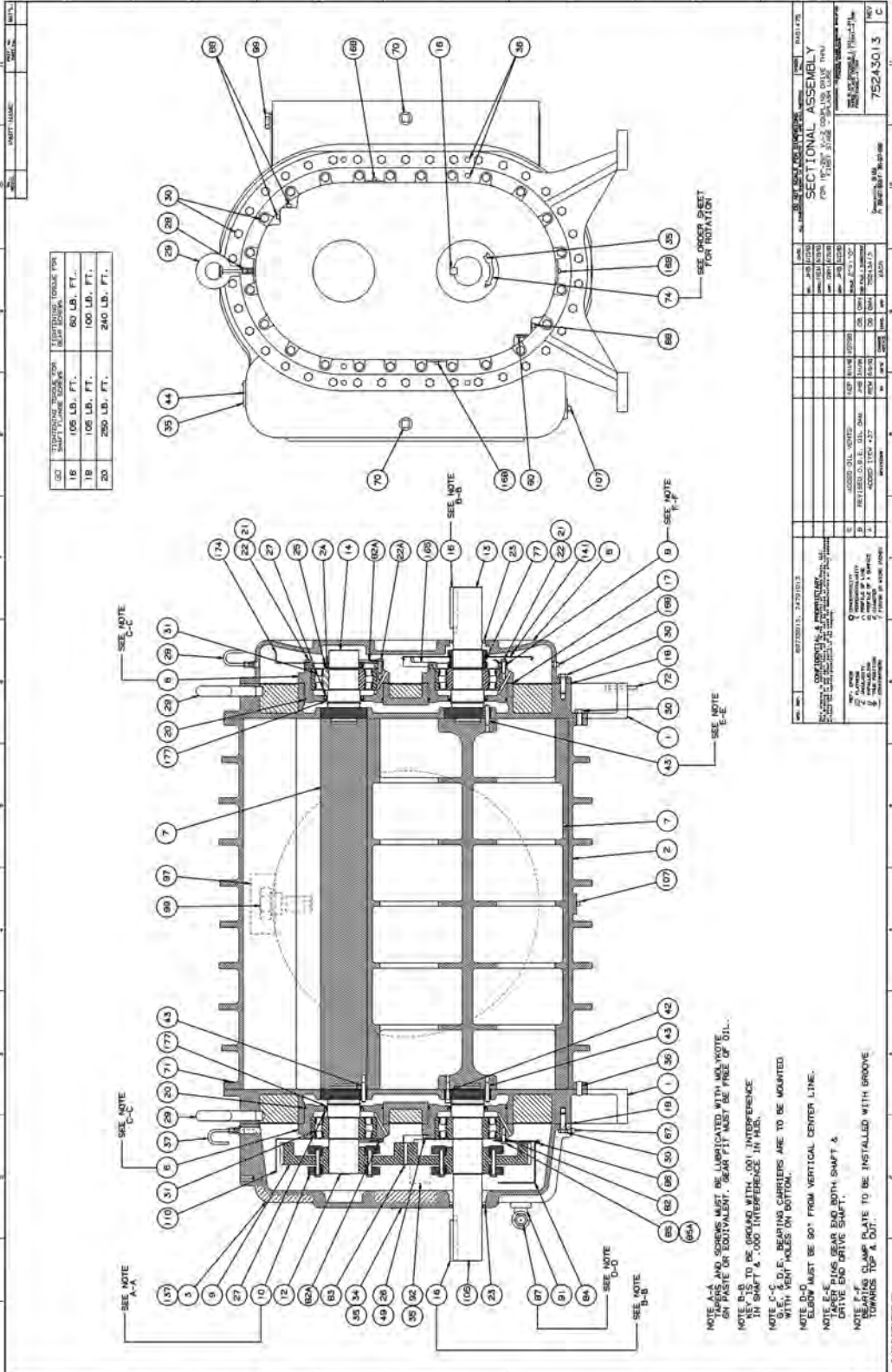

SECTION	APPROXIMATE WEIGHT FOR STARTING TORQUE PER
16	100 LB. FT.
18	100 LB. FT.
20	200 LB. FT.
24	240 LB. FT.

NO.	REV.	DATE	BY	CHKD.	DESCRIPTION
1					ISSUED FOR CONSTRUCTION
2					ISSUED FOR CONSTRUCTION
3					ISSUED FOR CONSTRUCTION
4					ISSUED FOR CONSTRUCTION
5					ISSUED FOR CONSTRUCTION
6					ISSUED FOR CONSTRUCTION
7					ISSUED FOR CONSTRUCTION
8					ISSUED FOR CONSTRUCTION
9					ISSUED FOR CONSTRUCTION
10					ISSUED FOR CONSTRUCTION
11					ISSUED FOR CONSTRUCTION
12					ISSUED FOR CONSTRUCTION
13					ISSUED FOR CONSTRUCTION
14					ISSUED FOR CONSTRUCTION
15					ISSUED FOR CONSTRUCTION
16					ISSUED FOR CONSTRUCTION
17					ISSUED FOR CONSTRUCTION
18					ISSUED FOR CONSTRUCTION
19					ISSUED FOR CONSTRUCTION
20					ISSUED FOR CONSTRUCTION
21					ISSUED FOR CONSTRUCTION
22					ISSUED FOR CONSTRUCTION
23					ISSUED FOR CONSTRUCTION
24					ISSUED FOR CONSTRUCTION
25					ISSUED FOR CONSTRUCTION
26					ISSUED FOR CONSTRUCTION
27					ISSUED FOR CONSTRUCTION
28					ISSUED FOR CONSTRUCTION
29					ISSUED FOR CONSTRUCTION
30					ISSUED FOR CONSTRUCTION
31					ISSUED FOR CONSTRUCTION
32					ISSUED FOR CONSTRUCTION
33					ISSUED FOR CONSTRUCTION
34					ISSUED FOR CONSTRUCTION
35					ISSUED FOR CONSTRUCTION
36					ISSUED FOR CONSTRUCTION
37					ISSUED FOR CONSTRUCTION
38					ISSUED FOR CONSTRUCTION
39					ISSUED FOR CONSTRUCTION
40					ISSUED FOR CONSTRUCTION
41					ISSUED FOR CONSTRUCTION
42					ISSUED FOR CONSTRUCTION
43					ISSUED FOR CONSTRUCTION
44					ISSUED FOR CONSTRUCTION
45					ISSUED FOR CONSTRUCTION
46					ISSUED FOR CONSTRUCTION
47					ISSUED FOR CONSTRUCTION
48					ISSUED FOR CONSTRUCTION
49					ISSUED FOR CONSTRUCTION
50					ISSUED FOR CONSTRUCTION
51					ISSUED FOR CONSTRUCTION
52					ISSUED FOR CONSTRUCTION
53					ISSUED FOR CONSTRUCTION
54					ISSUED FOR CONSTRUCTION
55					ISSUED FOR CONSTRUCTION
56					ISSUED FOR CONSTRUCTION
57					ISSUED FOR CONSTRUCTION
58					ISSUED FOR CONSTRUCTION
59					ISSUED FOR CONSTRUCTION
60					ISSUED FOR CONSTRUCTION
61					ISSUED FOR CONSTRUCTION
62					ISSUED FOR CONSTRUCTION
63					ISSUED FOR CONSTRUCTION
64					ISSUED FOR CONSTRUCTION
65					ISSUED FOR CONSTRUCTION
66					ISSUED FOR CONSTRUCTION
67					ISSUED FOR CONSTRUCTION
68					ISSUED FOR CONSTRUCTION
69					ISSUED FOR CONSTRUCTION
70					ISSUED FOR CONSTRUCTION
71					ISSUED FOR CONSTRUCTION
72					ISSUED FOR CONSTRUCTION
73					ISSUED FOR CONSTRUCTION
74					ISSUED FOR CONSTRUCTION
75					ISSUED FOR CONSTRUCTION
76					ISSUED FOR CONSTRUCTION
77					ISSUED FOR CONSTRUCTION
78					ISSUED FOR CONSTRUCTION
79					ISSUED FOR CONSTRUCTION
80					ISSUED FOR CONSTRUCTION
81					ISSUED FOR CONSTRUCTION
82					ISSUED FOR CONSTRUCTION
83					ISSUED FOR CONSTRUCTION
84					ISSUED FOR CONSTRUCTION
85					ISSUED FOR CONSTRUCTION
86					ISSUED FOR CONSTRUCTION
87					ISSUED FOR CONSTRUCTION
88					ISSUED FOR CONSTRUCTION
89					ISSUED FOR CONSTRUCTION
90					ISSUED FOR CONSTRUCTION
91					ISSUED FOR CONSTRUCTION
92					ISSUED FOR CONSTRUCTION
93					ISSUED FOR CONSTRUCTION
94					ISSUED FOR CONSTRUCTION
95					ISSUED FOR CONSTRUCTION
96					ISSUED FOR CONSTRUCTION
97					ISSUED FOR CONSTRUCTION
98					ISSUED FOR CONSTRUCTION
99					ISSUED FOR CONSTRUCTION
100					ISSUED FOR CONSTRUCTION

NOTE A-A  
TURNS AND SCREWS MUST BE LUBRICATED WITH MOLYBDENE  
ON PASTE OR EQUIVALENT. GEAR FIT MUST BE FREE OF OIL.  
NOTE B-B TO BE GROUNDED WITH .001 INTERFERENCE  
IN SHAFT & .000 INTERFERENCE IN HUB.  
NOTE C-C, D-D, E-E, BEARING CARRIERS ARE TO BE MOUNTED  
WITH VENT HOLES ON BOTTOM.  
NOTE D-D  
ELBOW MUST BE 90° FROM VERTICAL CENTER LINE.  
NOTE E-E  
DRIVE END DRIVE SHAFT &  
NOTE F-F  
DRIVE END DRIVE SHAFT &  
TOWARD TOP & OUT

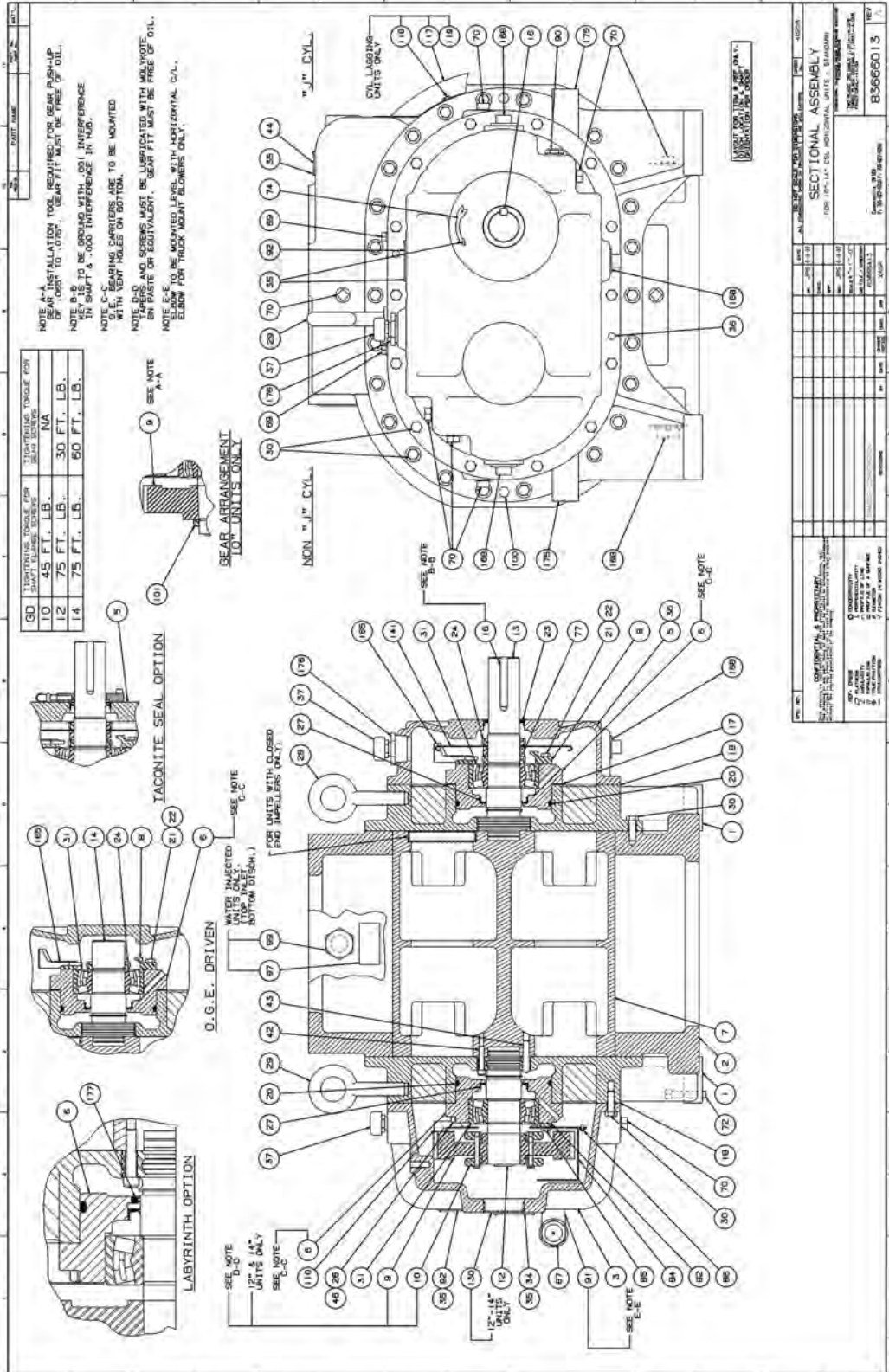

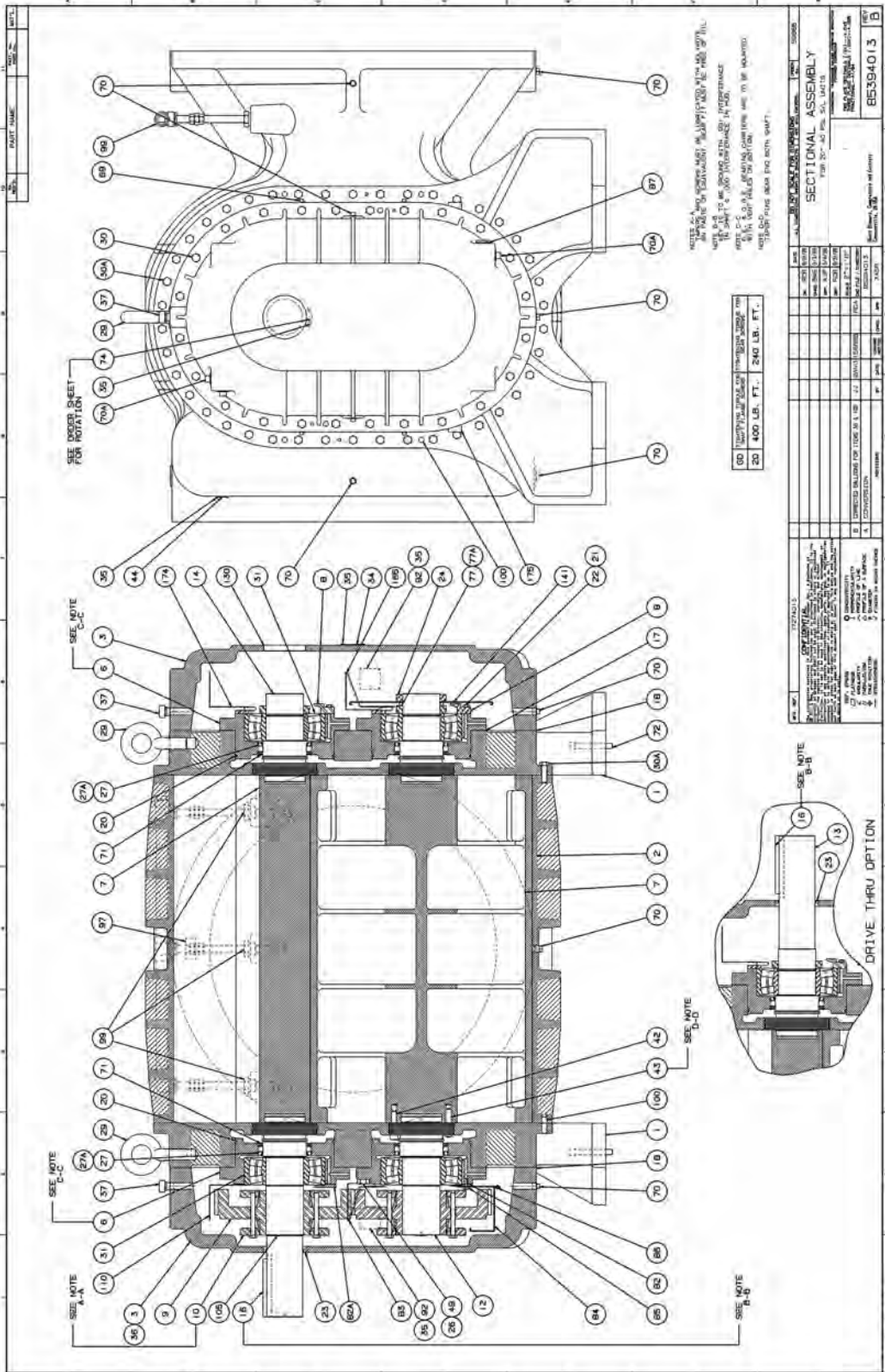

### Parts Identification List for Figure 16

Item Number	Quantity Used	Identificatio
1	1	Headplate - Gear End
1A	1	Headplate - OGE
2	1	Cylinder
3	1	Gearbox
5	1	End Cover - Driving (Cplg.)
5A	1	End Cover - Driven Shaft
6	4"	Bearing Carrier
7	2	Impeller
9	2	Timing Gear
10	2	Timing Gear Locking Assembly
12	2	Stub Shaft - Gear End
13	2	Stub Shaft - Driving
14	1	Stub Shaft - Driven
15		
16	1	Key - Drive Sheave or Coupling
17	4 halves	Shims - Brng. Carrier, OGE
18	1	Gasket - Gearbox Flange
22	Varies	Capscrew - End Cover (Soc. Hd.)
23	1	Shaft Seal - Outboard
24	2	Bearing Locknut
25	2	Bearing Lockwasher
26	8	Lockwasher - Brng. Carrier (See 49)
27	4	Shaft Seal - Inboard
28	2	Air Vent - OGE
29	2	Eyebolt - Lifting
30	Varies	Capscrew - Gearbox & Headplate Flg.
31	4	Bearing - Roller
34	1	Nameplate
35	6	Drive Screw - Nameplate & Arrow
36	8 or 0 <sup>d</sup>	Dowel Pin - Flange Locating
37	1	Vent Plug - Gearbox
42	Varies	Capscrew - Stub Shaft (Soc. Hd.)
43	Varies	Taper Pin - Stub Shaft, Gear End
45		
49	16	Capscrew - Brng. Carrier (See 26)
56		
58	1	End Cover - Driving (Belted)
60	1	Bearing - Inboard
61	2	O ring - End Cover

Item Number	Quantity Used	Identificatio
62	1	Spacer Sleeve - Outboard Brng.
63	1	Bearing Carrier - Extended Drive
64	2	Dowel Pin - End Cover
66	1	Air Vent - End Cover (Belted)
67	1	Plug - Gearbox Drain
69	4	Plug - Bearing Housing
70	4	Plug - Instrument Taps
71	2	Leveling Label
72	4	Set Screw - Leveling
73		
74	1	Rotation Arrow
75		
76		
77	1 or 2 <sup>c</sup>	Spacer Ring - OGE Bearing
78		
80		
81	2	Gasket - Brng. Carrier, Gear End
82	2	Oil Dam - Gear End Bearing
83	2	Oil Control Shield
84	1 or 2 <sup>b</sup>	Oil Pan (Secondary Sump)
85	4	Capscrew - Oil Pan
86	Varies	Self-Tap Screw - Oil Pan
87	1	Gauge Oil Level - Gear End
88	6	Plug - Drive end Fill & Drain
89	2	Locking Nut (See 96)
90	2	Gauge Oil Level - Drive End
91		
92	1	Lube Nameplate - Gear End
93	1	Lube Nameplate - OGE
94		
95		
96	2	Slinger Set Screw (See 89)
100	1	Dowel Pin - Flange Locating
110	1 or 0 <sup>d</sup>	Oil Shroud
111	1 or 0 <sup>d</sup>	Oil Dam Shield
177	4 or 0 <sup>d</sup>	Teflon Labyrinth

- a. All units having extended shaft for belt drive. Use three (3) from 6 and one (1) Item 63.
- b. Vertical style units, use one item 84. Horizontal units, require two (2) item 54.
- c. Use on sizes 1000 through 1400 only.
- d. Units of frame sizes 1000 through 1400, except four (4) item 100. Frames 1600 through 2000 and 14425 use eight (8) item 36.
- e. Vertical style units use one (1) item 110 and one (1) item 111. Not required on horizontal units.





**ROOTS™**

900 W. Mount St. Connersville  
Indiana, 47331, USA

**pdblowers**  
*inc*

BLOWERS. ACCESSORIES. PARTS. DESIGN. FABRICATION. SERVICE.

1-800-536-9933 | [customerservice@pdblowsers.com](mailto:customerservice@pdblowsers.com)

Find us online at [PDBLOWERS.COM](http://PDBLOWERS.COM)