

Figure 6 — Assembly of RCS Vertical Style Blowers

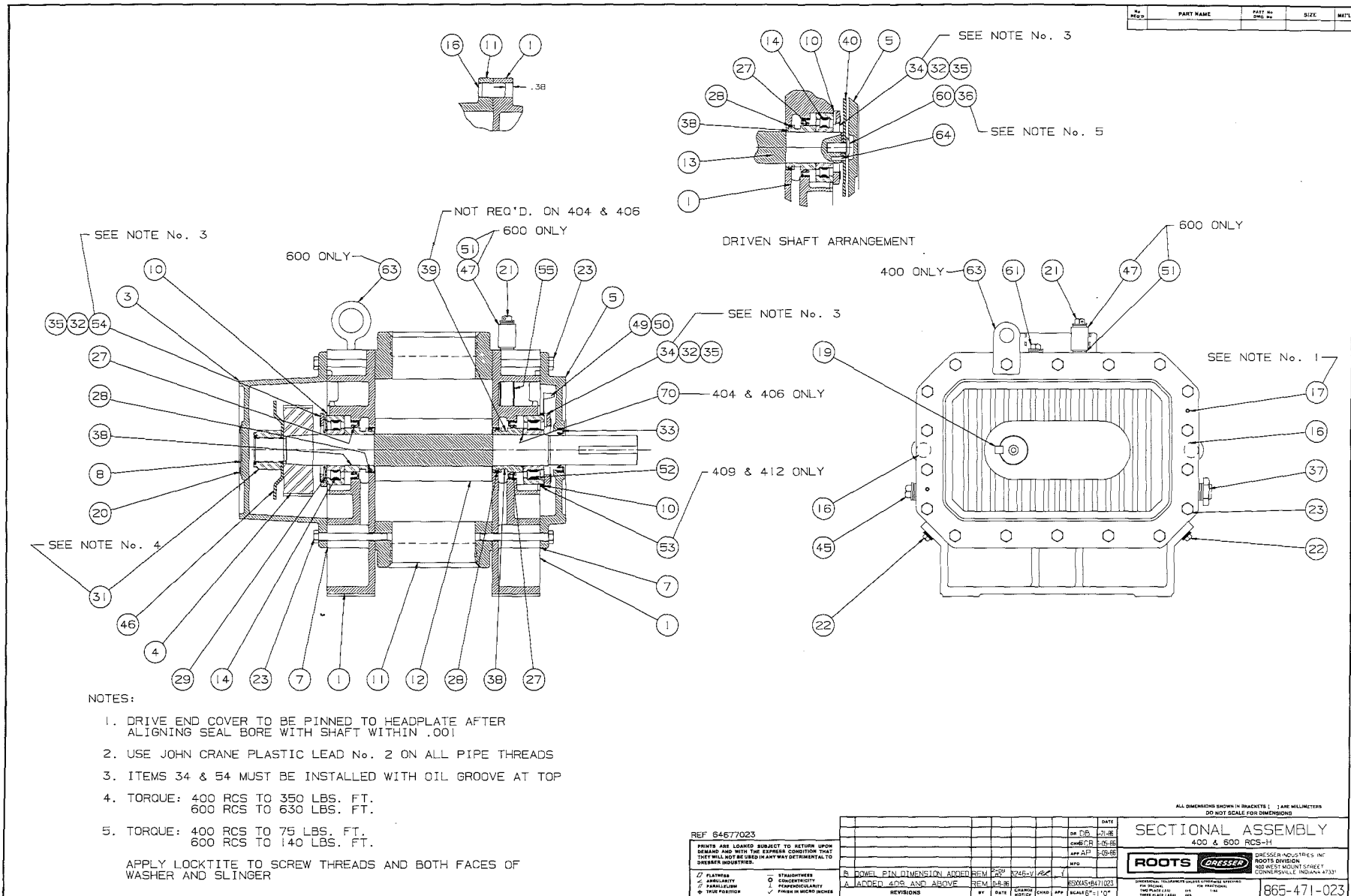

Figure 7 — Assembly of RCS Horizontal Style Blowers

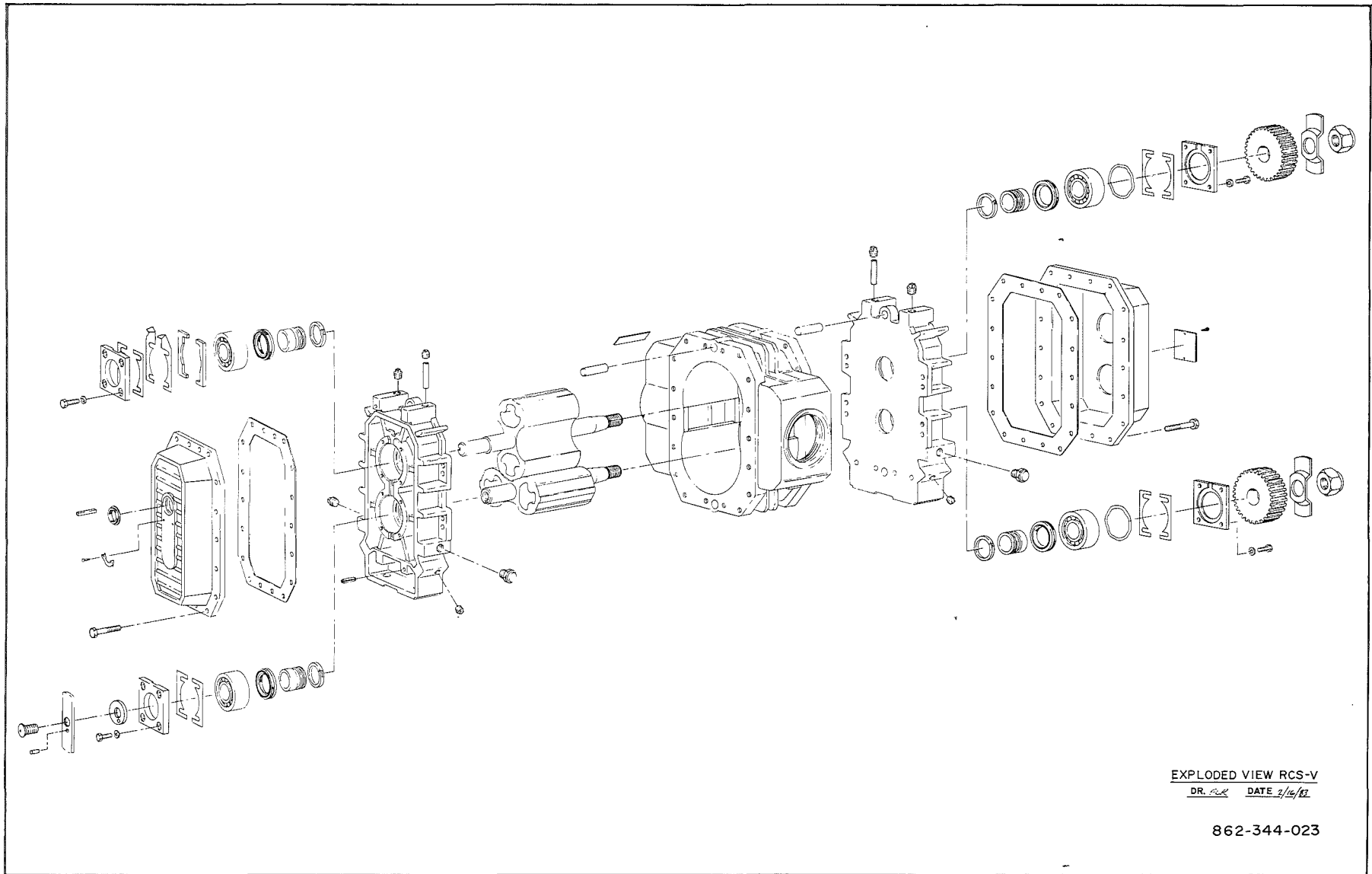

Figure 10 — Exploded View

Table 6 — Parts Identification List for Figures 6, 7, and 10

Item Number	Quantity Used	Identification	Item Number	Quantity Used	Identification
1	2	Headplate	28	4	Seal Ring
3	1	Gearbox	29	2	Washer - Wavy Spring
4	2	Gear	30	2	Washer - Gear Mounting
5	1	Drive End Cover	31	2	Locknuts
7	2	Gasket	32	16	Capscrew
8	1	Nameplate	33	1	Seal - Lip, D.E. Cover
9	2	Lubrication Label	34	2	Clamp Plate, Drive End
10	4	Shim	35	16	Lockwasher
11	1	Cylinder	36	1	Flatwasher
12	1	Impeller & Shaft - Drive	37	2	Oil Level Gauge
13	1	Impeller & Shaft - Driven	38	3	Sleeve
14	3	Bearing, Non - Drive	40	1	Slinger, D.E.
16	4	Dowel Pin	45	2	Pipe Plug
17	2	Driv-Lok Pin	46	1	Slinger, G.E.
19	1	Key	52	1	Bearing, D.E. Drive
20	4	Drive Screw	53	1	Spacer, Drive Bearing
21	2	Breather	54	2	Clamp Plate, Gear End
22	6	Drain - Filler Plug	55	2	Air Filter
23	36	Capscrew	60	1	Slinger Capscrew
27	4	Seal-Lip, Headplate	61	2	Filler Plug