

No. REQ'D.	PART NAME	PATT. No. PART No.	MATL.
------------	-----------	--------------------	-------

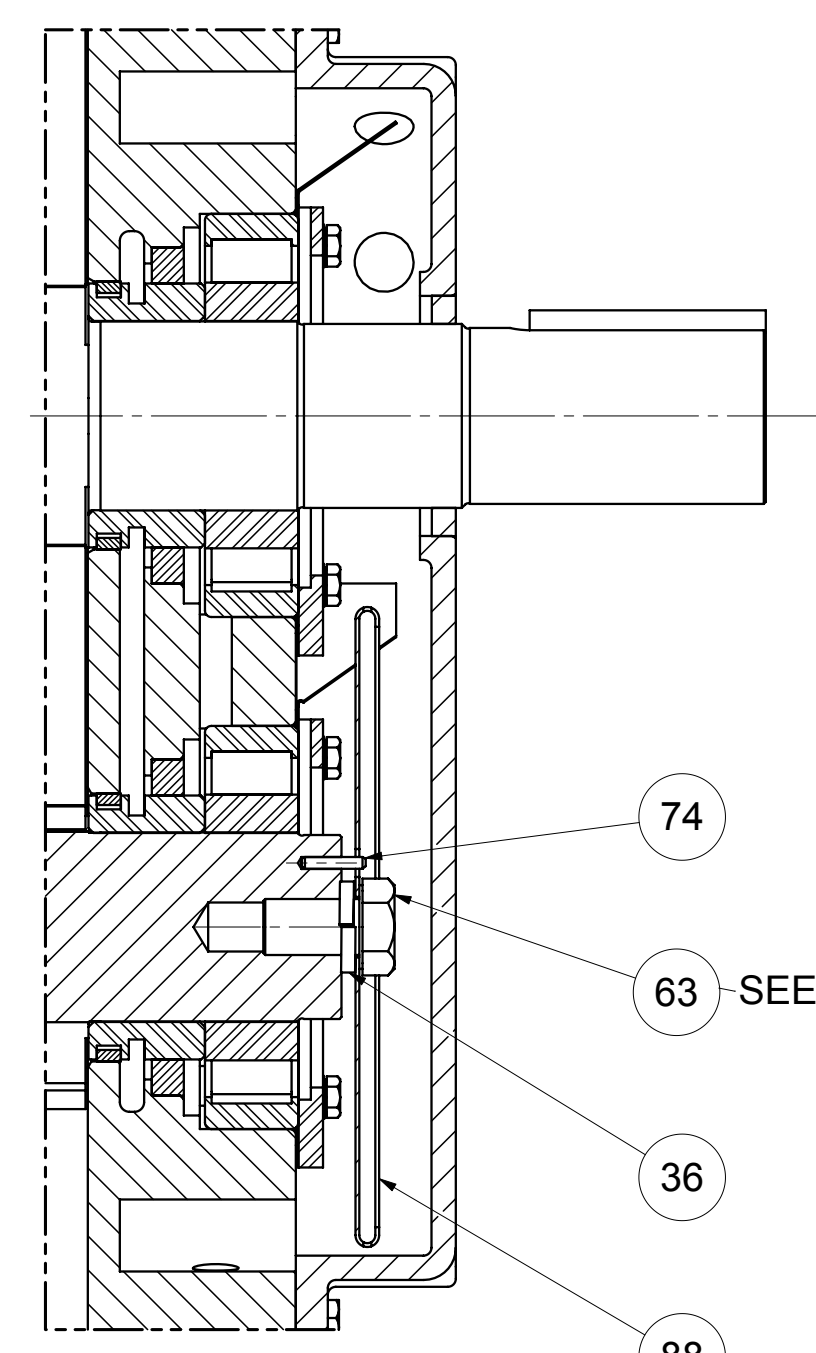

BOTTOM SLINGER FOR TOP DRIVE SHAFT ARRANGEMENT

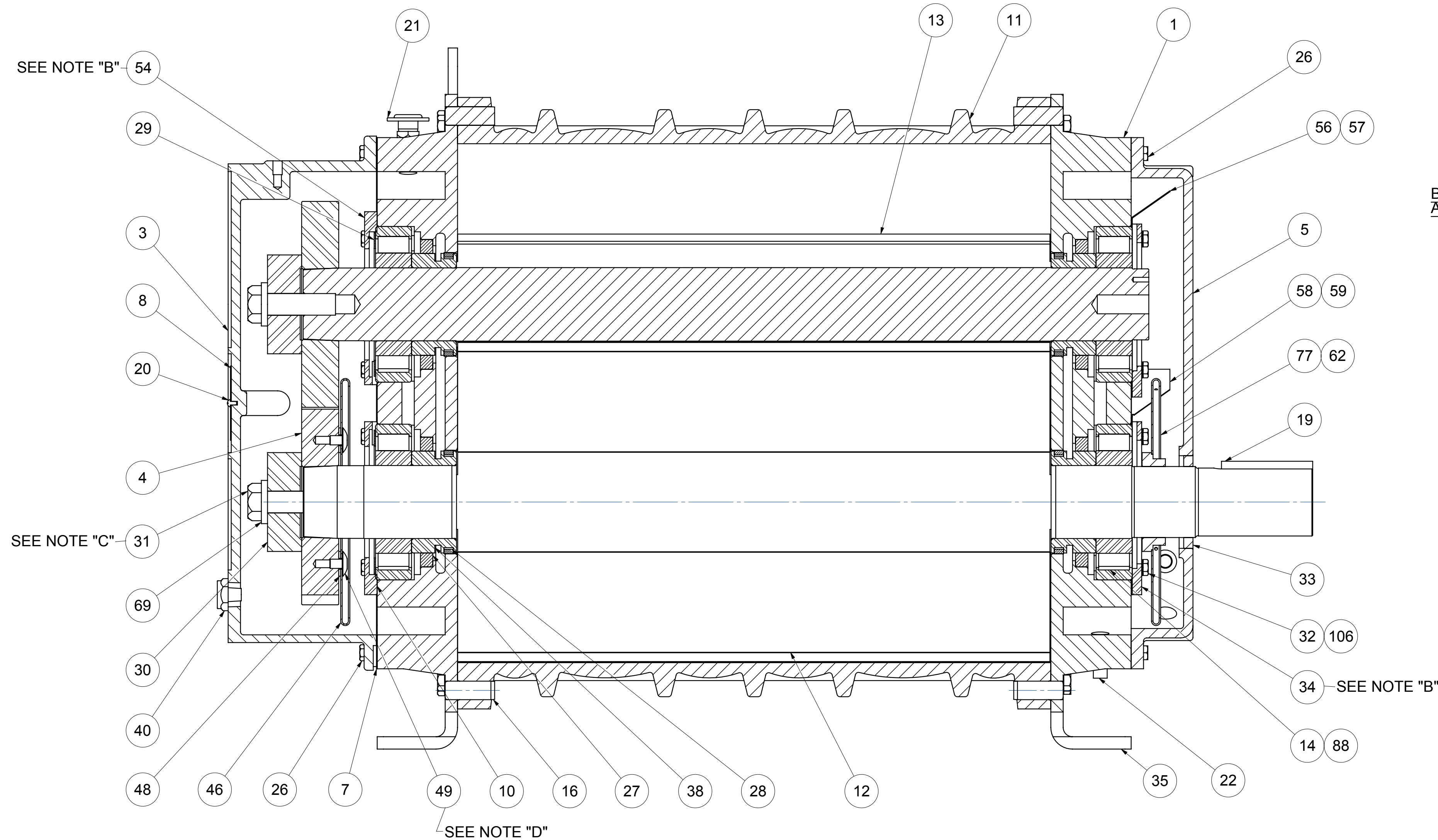
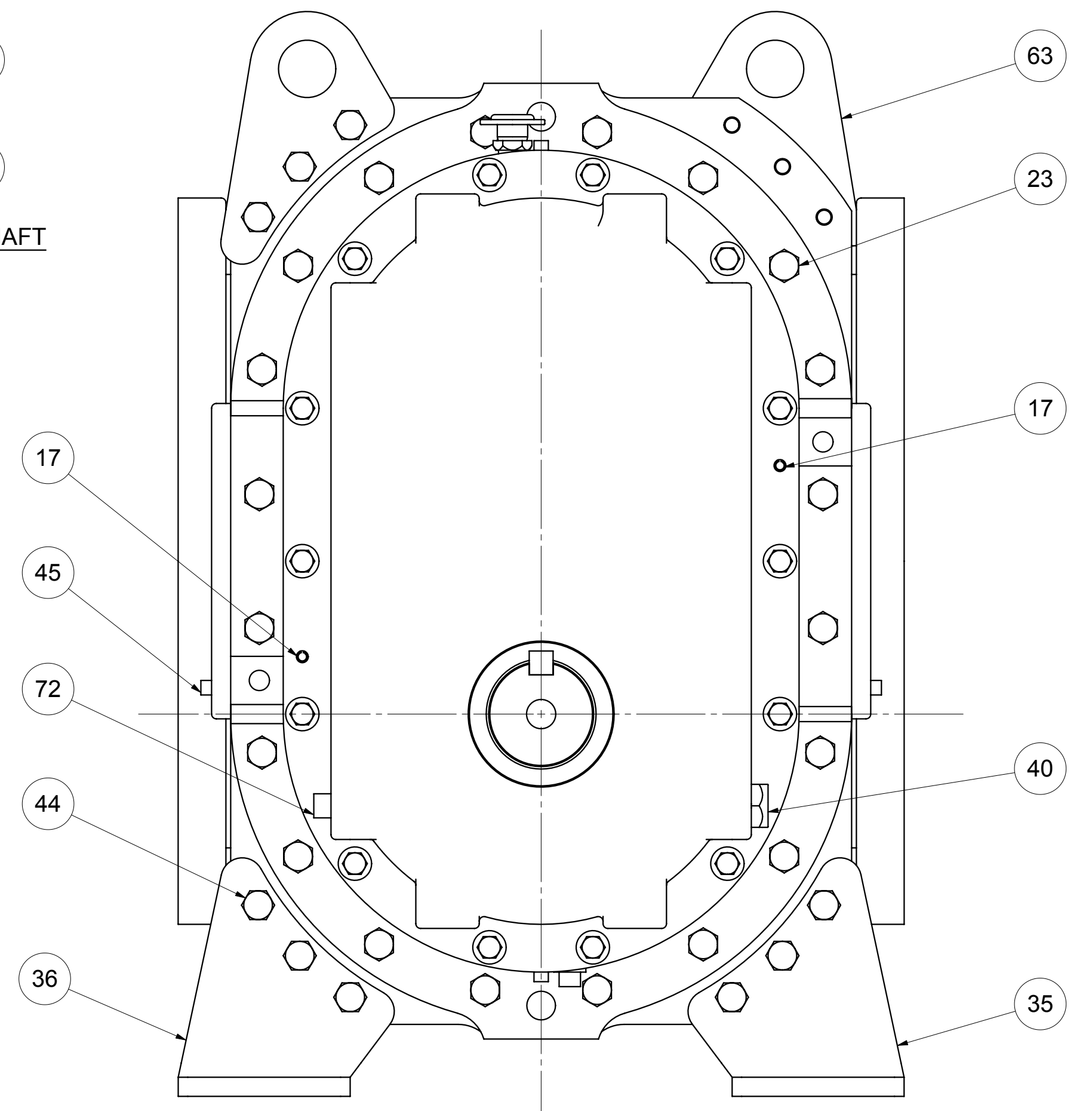

- NOTES:**
- A. USE LOCKTITE 567 ON ALL PIPE THREADS.
 - B. ITEMS 34 & 54 MUST BE INSTALLED WITH OIL GROOVE AT TOP.
 - C. APPLY OIL TO BOLT THREADS & UNDER BOLT HEAD & TORQUE TO 650 FT. LBS. (IF MOLYKOTE GN PASTE IS USED IN PLACE OF OIL ON THREADS, TORQUE TO 500 FT. LBS.)
 - D. THREADS MUST BE OIL FREE, CLEAN, APPLY LOCK TITE - 272 AND TORQUE TO 25 FT. LBS.
 - E. THREADS MUST BE OIL FREE, CLEAN, APPLY LOCK TITE - 272 AND TORQUE TO 450 FT. LBS.
 - F. SEE OPERATING MANUAL ISRB-2003 FOR LUBRICATION INSTRUCTIONS.

MFG. REF.	CONFIDENTIAL										DR.	DATE	DO NOT SCALE FOR DIMENSIONS ALL DIMENSIONS SHOWN IN BRACKETS [] ARE MILLIMETERS	ORDER No.						
THIS DOCUMENT CONTAINS CONFIDENTIAL INFORMATION OF ROOTS DIVISION, DRESSER INDUSTRIES, INC. IT SHALL BE HELD IN STRICTEST CONFIDENCE, AND BE USED ONLY IN CONJUNCTION WITH ROOTS DIVISION BUSINESS.											CHKD.		SECTIONAL ASSEMBLY 8" RCS BLOWER	<small>DIMENSIONAL TOLERANCES UNLESS OTHERWISE SPECIFIED FINISHED DIMENSIONS</small> TWO PLACE DECIMALS (.XX) ±0.015 THREE PLACE DECIMALS (.XXX) ±0.005 FRACTIONAL ±1/64						
REF: EP938	□ FLATNESS	∠ ANGULARITY	// PARALLELISM	⊕ TRUE POSITION	— STRAIGHTNESS	◎ CONCENTRICITY	⊥ PERPENDICULARITY	— PROFILE OF LINE	⊖ PROFILE OF A SURFACE	∅ DIAMETER	✓ FINISH IN MICRO INCHES	APP.			SCALE					
											DBV									
											APP.									
											SCALE									
											CAD FILE / DIRECTORY									
											A	RELEASED								
											REVISIONS	BY	DATE	CHANGE NOTICE	CHKD.	APP.	RH-201503023	Dresser Roots, Dresser, Inc. Connersville, IN USA	RH-201503023 SHEET 1 OF 1	REV A