

33 URAI

pdblowers part #: 21012.C (LHC), 21013 (RHC), 21014 (BHC), 21015 (THC)

Roots part #: 6510502L, 6510502R, 6510502B, 6510502T

Specifications

Max Flow:	198 ACFM	Connection Size:	2" FPT
Min Flow:	44 ACFM	Shaft Diameter:	0.750"
Max Pressure:	12 PSI	Weight:	74 lb
Max Vacuum:	15 "HG	Shipping Weight:	103 lb
Max RPM:	3600 RPM	Ship Dimensions:	30x30x15"
Min RPM:	1090 RPM	Drive End:	Grease, Synthetic
Max ΔT:	225°F	Gear End:	Oil (8.5oz vertical, 10.5oz horizontal)
CFR:	0.0616		
1 PSI Slip:	267 RPM		



Pressure Curve

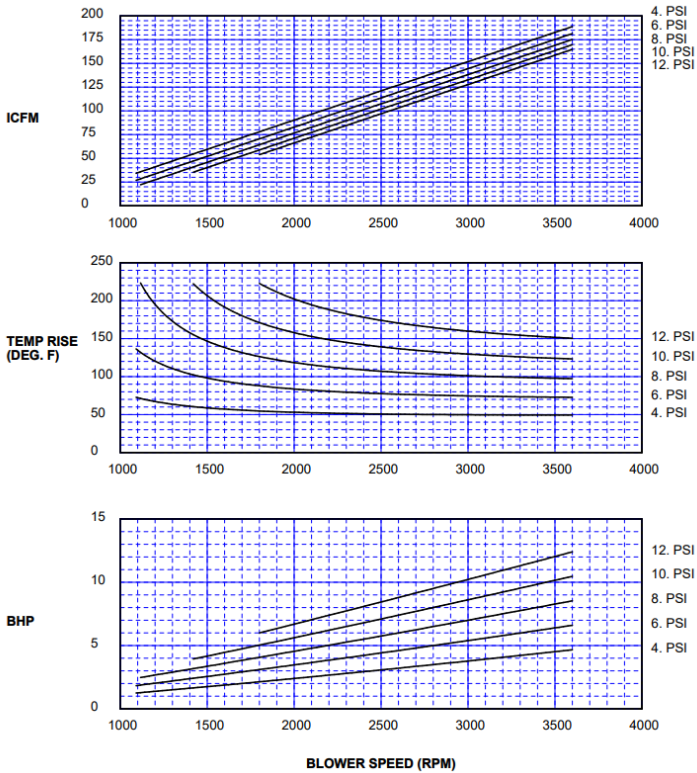

Vacuum Curve

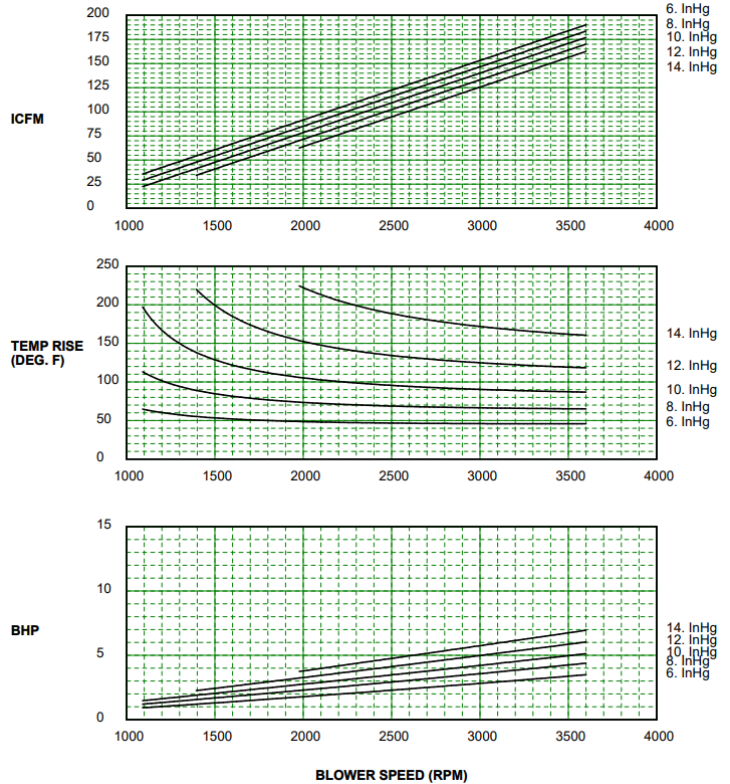

Oil recommendations

Ambient Temp	ISO Viscosity	pdblows part #:				
		Quart	12 Qt	Gallon	4 Gal	5 Gal
90° to 120° (32°C)	320	54525	54529	53204	53204.C	54532
32° to 90° (10°C to 32°C)	220	54524	54528	54527	54527.C	54531
0° to 32° (-18°C to 0°C)	150	54585	54586	54049	54049.C	57229
Below 0° (-18°C)	100	57060	54048	50754	50754.C	54584

Oil service interval is approximately 6000 hours with an oil temp of 180°F or less. Oil life is reduced by half for each 15°F increase in oil temp.

Grease Recommendations

Grease is used for URAI blowers for lubrication on the drive end bearings. Blowers manufactured before 10/2016 typically use Shell Gadus grease (pdblows part #: 54649). All blowers produced after 10/2016 use Roots synthetic grease (pdblows part #: 25673).

Note: the two can NOT be mixed.

Speed In RPM	Operating Hours Per Day		
	8	16	24
	Greasing Interval in Weeks		
750-1000	7	4	2
1000-1500	5	2	1
1500-2000	4	2	1
2000-2500	3	1	1
2500-3000	2	1	1
3000+	1	1	1

33 URAI

Part Diagram

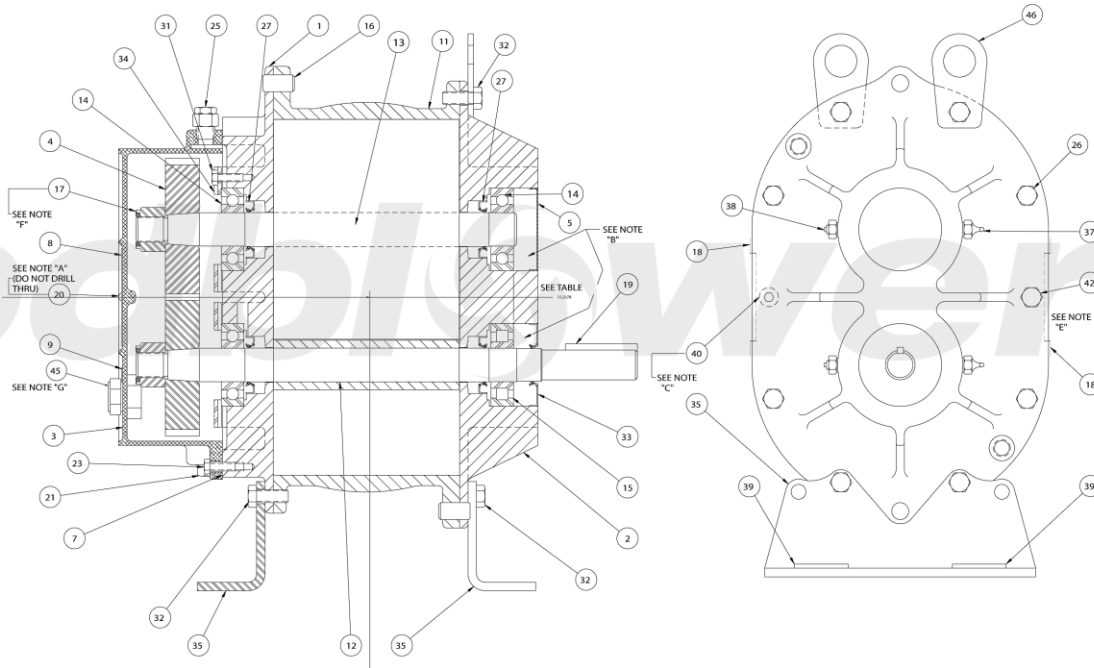

Part Listing

Ref	Description	Qty	Mfg PN	pdb PN
001	HDPL GE 3-1/2" URAI	1	64860022	26406.01
002	HDPL DE 3-1/2" URAI	1	64855022	26406.01
003	GRBX, 3-1/2" URAI	1	65332022	26406.03
004	GEAR,ASSY 3-1/2" URAI T/B	1	63889021	26406.04
005	PLUG,OPENING FOR 2.0474" BORE	1	12957003	26406.05
007	GSKT,GRBX 3-1/2"URAI TS9003	1	62752021	26406.07
011	CYL 33 URAI, Cylinder	1	38992022	26406.11.33
012	Drive End Impeller	1	64863022	26406.12.33
013	Driven End Impeller	1	64863522	26406.13.33
014	BRG,BALL FAG #6304	3	10987002	26406.14
015	BRG,ROLLER FAG #NJ304E	1	10222035	26406.15
016	PIN,DOWL 1/2X1.00	4	10226001	26406.16
017	NUT,HEX ESNA 5/8-18	2	10319007	26406.17
019	KEY,SQ 3/16"X 3/16"X 1-5/8"	1	10825005	26406.19
020	SCR,SELF-TPNG RNDH 8-32X.25	1	10815002	26406.20
021	PLG,PIPE 1/4 STL	3	10008002	26406.21
025	PLUG,VENT 1/4"	1	13005001	26400.25
027	SEAL,LIP(VITON) 13/16"SFT	4	10005157	26406.27
031	SCR,CAP HEXH NYL 1/4-20X.50	4	11540003	26406.31
033	SEAL,LIP(BUNA-N) 3/4" SFT	1	10005172	26406.33
034	PLT,CLAMP 3-1/2" UNIT	2	64449020	26406.34
035	BLWR,FOOT 3-1/2 URAI	2	64999021	26406.35
037	FITTING,GREASE 1/8"MPT	2	10007001	26406.37
038	PLUG,VENT 1/8"	2	13002001	26400.38
039	WSHR,OBLONG 1 1/2 SLOT	4	12892001	26406.39
046	URAI LIFTING, LUG	2	64361020	26414.42

Standard Repair Kit (651050RK / 26406) includes blue highlighted items

Standard Repair Kit with Gears (651040RK/ 26405) includes blue & green items

Dimensional Drawings – Horizontal

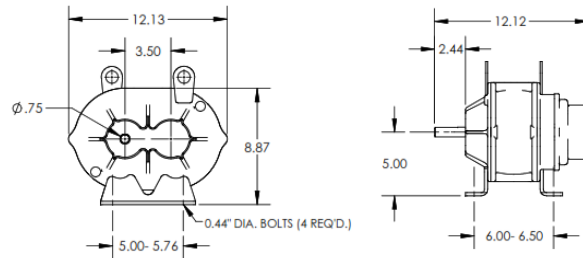

Dimensional Drawings – Vertical

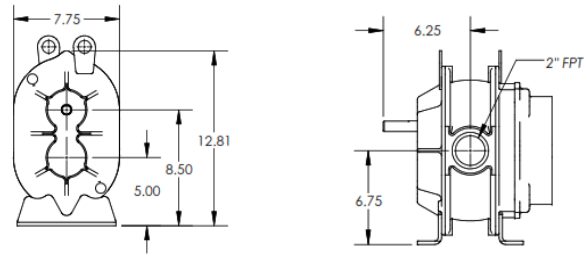

Clearances

Impeller/Impeller: 0.010-0.012"
 Impeller End to Headplate
 DE & GE: 0.003-0.008"
 GE w/ Spring Installed: 0.003"
 Impeller Tips to Cylinder:
 Inlet & Discharge: 0.004-0.006"
 Center: 0.002-0.003"

Critical Dimensions

Impeller Width: 5.675-5.676"
 Shaft Dia. at Bearing Bore:
 2.0472-2.0473"
 Bearing Bore Dia.: 0.7875-0.7879"

Materials of Construction

HEADPLATE MATERIAL: CAST IRON ASTM A48 CLASS 30B
 CYLINDER MATERIAL: CAST IRON ASTM A48 CLASS 30B
 IMPELLER MATERIAL: CAST IRON ASTM A48 CLASS 30B

SHAFT MATERIAL: STEEL, PRESS THRU ASTM 108-90 & 311-90
 HEADPLATE SEAL (4): LABYRINTH - INTEGRAL W/ SHAFT FLANGE
 BEARING SEAL (4): RADIAL LIP VITON

DRIVE SHAFT SEAL: RADIAL LIP BUNA-N
 GEAR MATERIAL: SAE 8620 STEEL CARBURIZED, HT 58-62 Rc
 GEAR RATING: AGMA -#11