

# VB019S, VB019

## Spencer Vortex® Regenerative Blowers

Available with a single phase TEFC motor (VB019S) or a three phase TEFC motor (VB019).

- Flow to 160 CFM
- 2½ hp
- NEMA Class F Insulation
- CE, UL Listed, CSA Certified Motor



	Freq	Max Volume		Max Operating Pressure		Max Operating Vacuum		hp	Standard Voltage	FLA Current	Locked Rotor Current	Speed	Estimated Acoustical Noise Level	Weight	
		Hz	cfm	m³h	"H₂O	mbar	"H₂O		mbar	Volts	Amperes			Amperes	@ 1.5m
VB019S	60	160	271.9	76	189.3	64	159.4	2.5	115/208-230, 1Ø	22/11.5-11	138/62.4-69	3450	70dba@60Hz	90	40.9
	50	133	226	52	129.5	46	114.6	2.1	100-110/220, 1Ø	22-21/10.5	122.7-135/67.5	2850		90	40.9
VB019	60	160	271.9	76	189.3	64	159.4	2.5	200-230/460, 3Ø	6.6-6/3	47-54/27	3450	73dba@60Hz	85	38.6
	50	133	226	52	129.5	46	114.6	2.1	190/380-415, 3Ø	6.2-3.1/2.9	55.7/27.8-25.5	2900		85	38.6

Maximum Ambient Temperature: 104°F/40°C. Maximum Internal Motor Temperature: 311°F/155°C.

### PERFORMANCE ADVANTAGES

**COMPACT LIGHTWEIGHT DESIGN:** A single stage blower with a C-faced motor and aluminum castings means minimal weight and footprint.

**EXCELLENT PERFORMANCE RANGE:** The range of standard models in the Vortex line provide volumes to 645 SCFM, vacuum ratings to 104" H2O, and pressures to 108" H2O.

**LONG-LIFE RELIABILITY:** Minimal maintenance and long life with only five major components: base, housing, impeller, bearings and motor. Each component was carefully designed for strength and heat tolerance to prevent failure.

**OIL-FREE AIR DELIVERY:** All motors have double sealed bearings and no grease fittings. With no hydrocarbon entrainment, Vortex blowers are suitable for the stringent requirements of healthcare and scientific applications.

**LESS HEAT AND NOISE:** Special design considerations like the single-sided impeller, annular chamber for laminar airflow and aluminum housing reduce heat and noise.

**APPLICATION FLEXIBILITY:** This constant velocity blower has no pulsation or surging; it can be run in reverse without loss of performance; and it can operate on 50Hz without modification. 3-phase models are inverter (VFD) ready.

### DIVERSE APPLICATIONS

Vortex blowers are particularly well-suited for applications within printing, food and chemical processing, textile, metalworking, waste treatment, environmental protection, aquaculture, business machine and medical equipment. These are some typical uses involving holding, carrying, evacuating, transferring, aerating and ventilating:

#### PRESSURE

- Air beds and tables
- Refuse burning
- Automatic loading
- Product drying
- Air cushioning
- Liquid agitation
- Sewage aeration
- Pellet conveying
- Blister packaging
- Liquid spraying
- Fuel atomization
- Air knives
- Stack sampling
- Fluidized beds
- Respiratory systems

#### VACUUM

- Radon gas elimination
- Automatic bottling
- Pneumatic conveying
- Vacuum hold-down
- Soil remediation
- Paper transporting
- Scrap collection
- Powder recovery
- Gas sampling
- Thread holding
- Dust collection
- Trim removal
- Small vacuum systems
- Parts handling
- Material pickup

## PERFORMANCE

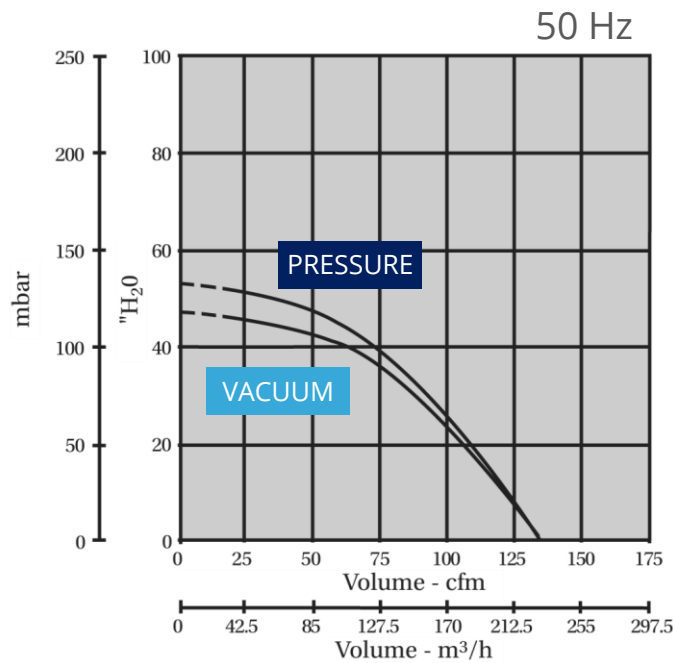
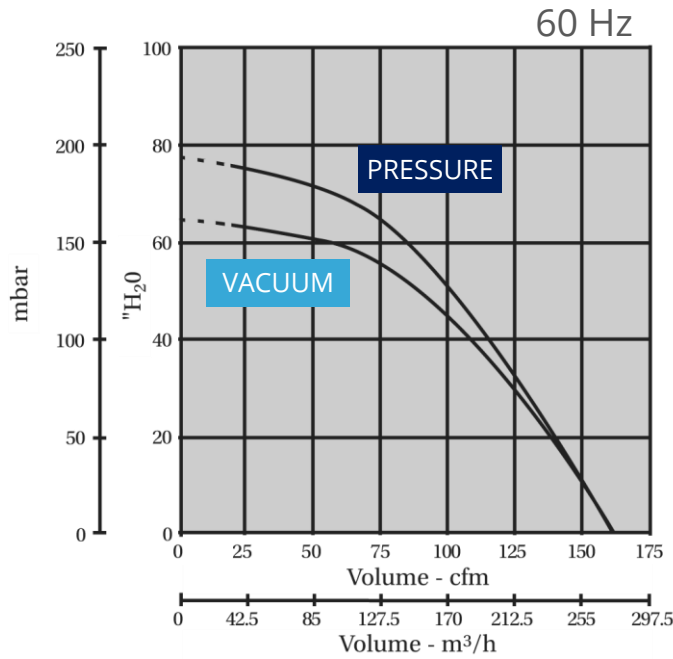

## DIMENSIONS

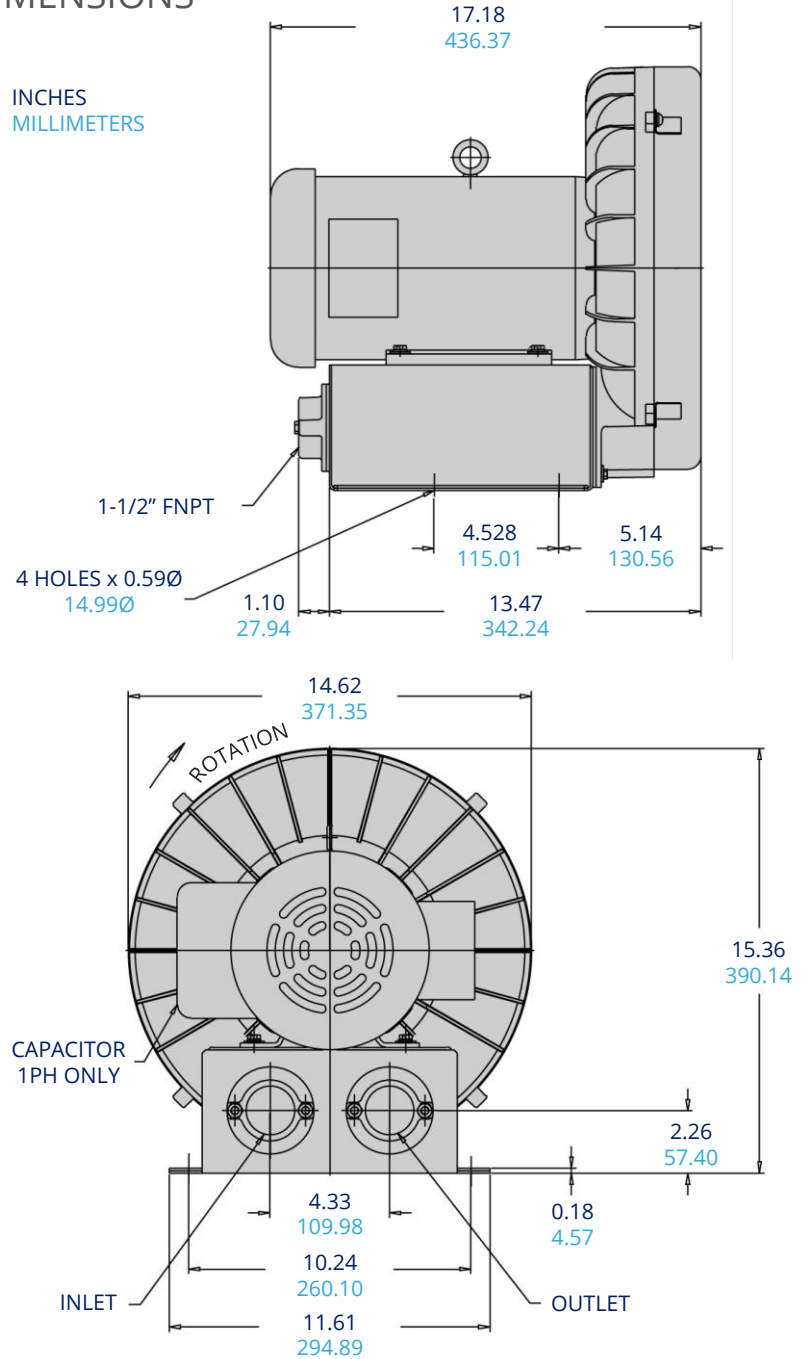

## MODEL VARIATIONS

### VB019 Options Available

MODEL	PART NUMBER
VB019 (Three Phase)	VBA91911
VB019S (Single Phase)	VBA91912
VB019BZ (575 Volt)	VBA91915
VB019 XP (3P, Explosion Proof)	VBA91908
VB019S XP (1P, Explosion Proof)	VBA91917

## ACCESSORIES & PACKAGES

pdblowers supplies all of the accessories needed for your regen blower, including:

- Relief valves for pressure & vacuum
- Inlet filters for pressure systems
- Inline filters for vacuum systems
- Silencers and filter/silencers for noise reduction

For over 30 years pdblowers has specialized in building blower and vacuum pump systems. Contact us to discuss your application.

