

# VB110

## Spencer Vortex® Regenerative Blowers

Available with a three phase TEFC motor

- Flow to 645 CFM
- 15 hp
- NEMA Class F Insulation
- CE, UL Listed, CSA Certified Motor



|       | Freq | Max Volume |       | Max Operating Pressure |       | Max Operating Vacuum |       |      | Standard Voltage | FLA Current    | Locked Rotor Current | Speed | Estimated Acoustical Noise Level | Weight |     |
|-------|------|------------|-------|------------------------|-------|----------------------|-------|------|------------------|----------------|----------------------|-------|----------------------------------|--------|-----|
|       | Hz   | cfm        | m³h   | "H₂O                   | mbar  | "H₂O                 | mbar  | hp   | Volts            | Amperes        | Amperes              | rpm   | @ 1.5m                           | lb     | kg  |
| VB110 | 60   | 645        | 1096  | 102                    | 254.1 | 104                  | 259.1 | 15   | 200-230/460, 3Ø  | 38.5-35/17.5   | 250.4-288/144        | 3490  | 80dba@60Hz                       | 370    | 168 |
|       | 50   | 538        | 914.2 | 94                     | 234.2 | 76                   | 189.3 | 12.5 | 190/380-415, 3Ø  | 35.2/17.6-16.6 | 276/138-126.4        | 2880  |                                  | 370    | 168 |

Maximum Ambient Temperature: 104°F/40°C. Maximum Internal Motor Temperature: 311°F/155°C.

### PERFORMANCE ADVANTAGES

**COMPACT LIGHTWEIGHT DESIGN:** A single stage blower with a C-faced motor and aluminum castings means minimal weight and footprint.

**EXCELLENT PERFORMANCE RANGE:** The range of standard models in the Vortex line provide volumes to 645 SCFM, vacuum ratings to 104" H2O, and pressures to 108" H2O.

**LONG-LIFE RELIABILITY:** Minimal maintenance and long life with only five major components: base, housing, impeller, bearings and motor. Each component was carefully designed for strength and heat tolerance to prevent failure.

**OIL-FREE AIR DELIVERY:** All motors have double sealed bearings and no grease fittings. With no hydrocarbon entrainment, Vortex blowers are suitable for the stringent requirements of healthcare and scientific applications.

**LESS HEAT AND NOISE:** Special design considerations like the single-sided impeller, annular chamber for laminar airflow and aluminum housing reduce heat and noise.

**APPLICATION FLEXIBILITY:** This constant velocity blower has no pulsation or surging; it can be run in reverse without loss of performance; and it can operate on 50Hz without modification. 3-phase models are inverter (VFD) ready.

### DIVERSE APPLICATIONS

Vortex blowers are particularly well-suited for applications within printing, food and chemical processing, textile, metalworking, waste treatment, environmental protection, aquaculture, business machine and medical equipment. These are some typical uses involving holding, carrying, evacuating, transferring, aerating and ventilating:

#### PRESSURE

- Air beds and tables
- Refuse burning
- Automatic loading
- Product drying
- Air cushioning
- Liquid agitation
- Sewage aeration
- Pellet conveying
- Blister packaging
- Liquid spraying
- Fuel atomization
- Air knives
- Stack sampling
- Fluidized beds
- Respiratory systems

#### VACUUM

- Radon gas elimination
- Automatic bottling
- Pneumatic conveying
- Vacuum hold-down
- Soil remediation
- Paper transporting
- Scrap collection
- Powder recovery
- Gas sampling
- Thread holding
- Dust collection
- Trim removal
- Small vacuum systems
- Parts handling
- Material pickup

## PERFORMANCE

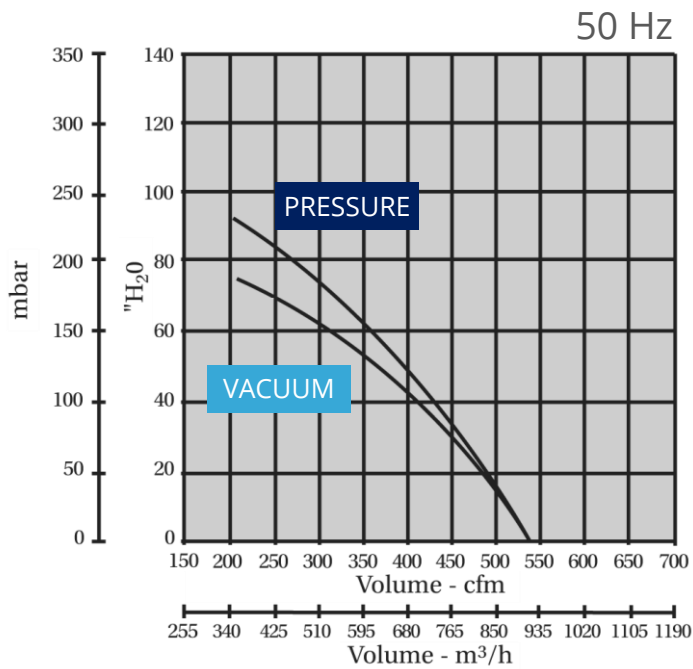
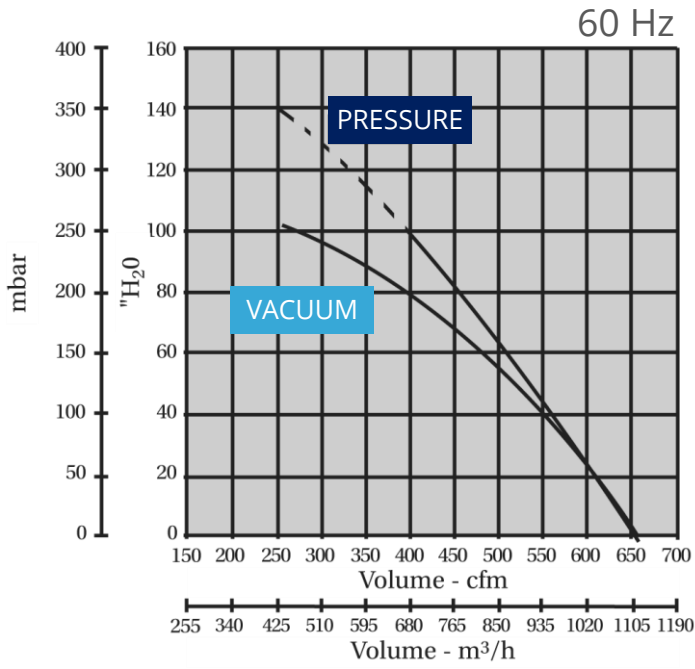

## DIMENSIONS

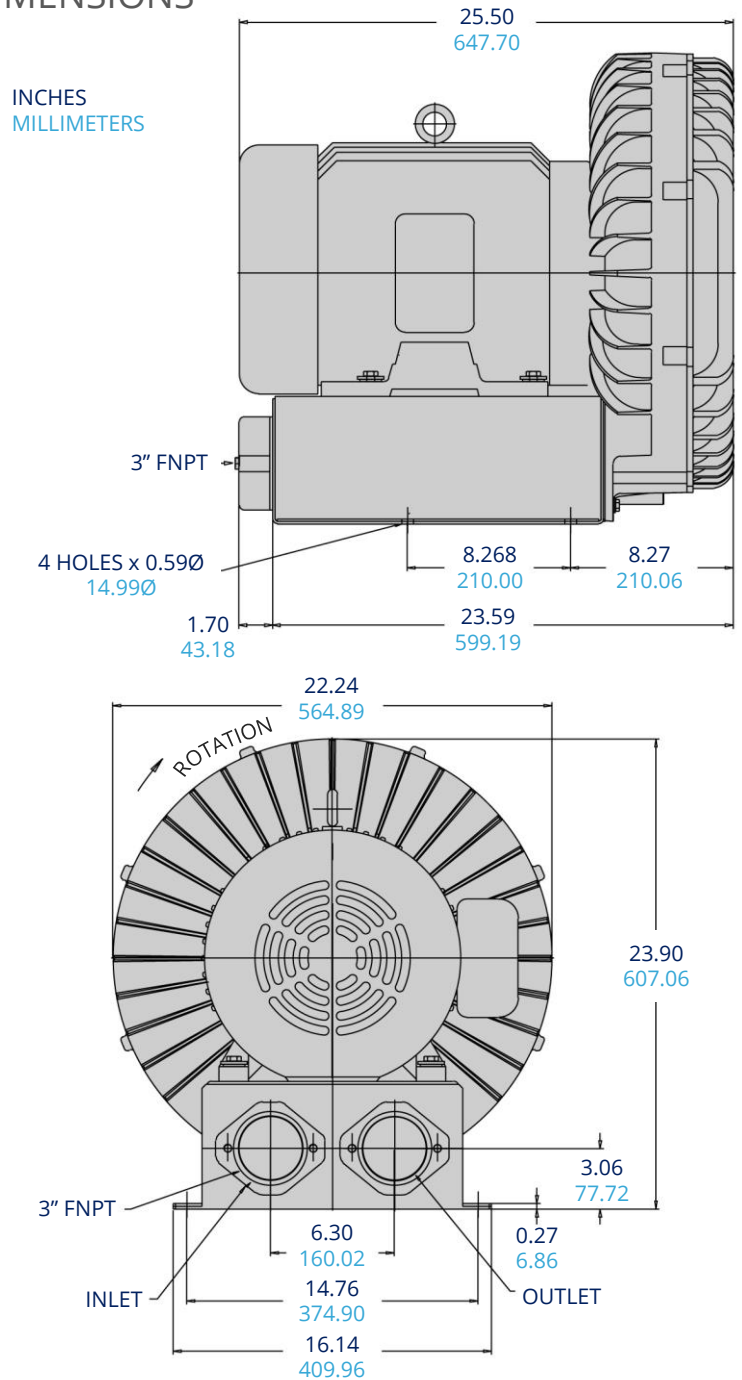

## MODEL VARIATIONS

### VB110 Options Available

| MODEL                          | PART NUMBER |
|--------------------------------|-------------|
| VB110 (Three Phase)            | VBA91101    |
| VB110BZ (575 Volt)             | VBA91103    |
| VB110 XP (3P, Explosion Proof) | VBA91104    |

## ACCESSORIES & PACKAGES

pdblowsers supplies all of the accessories needed for your regen blower, including:

- Relief valves for pressure & vacuum
- Inlet filters for pressure systems
- Inline filters for vacuum systems
- Silencers and filter/silencers for noise reduction

For over 30 years pdblowsers has specialized in building blower and vacuum pump systems. Contact us to discuss your application.

