

ZONE		REV	DESCRIPTION	DATE	DWN	CHK
A			RELEASED PER ECR 10/02/21			
B			REVISED AND REDRAWN PER ECR 10/01/16	09/14/2012	L&T	TAM

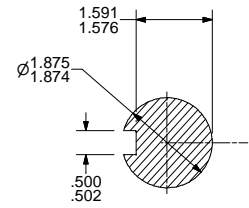

SECTION A-A
SCALE 1 : 1

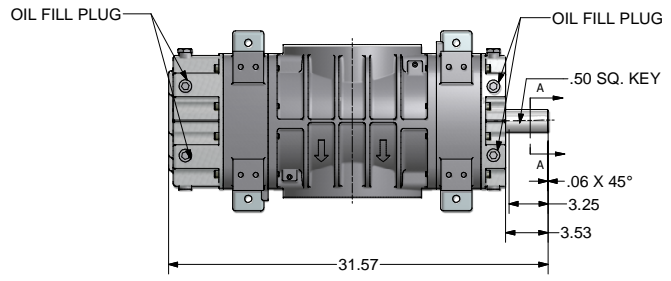
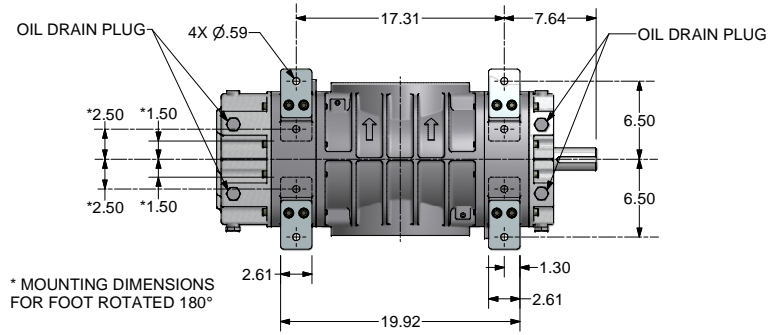
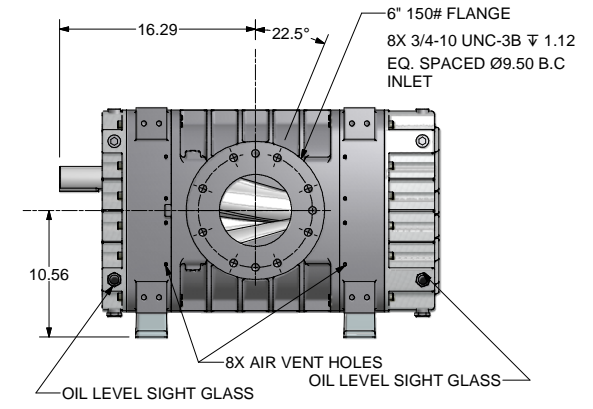
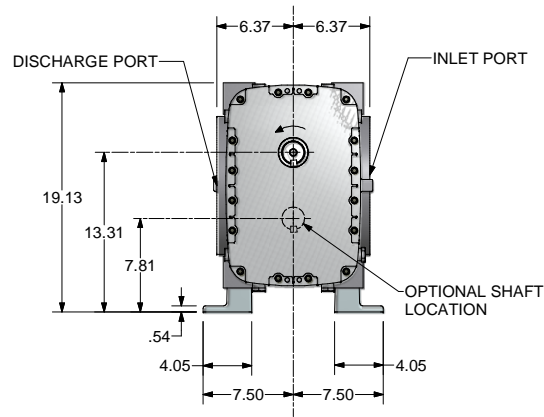
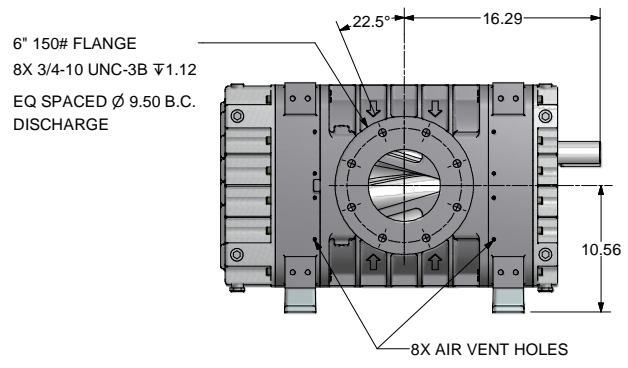

* MOUNTING DIMENSIONS FOR FOOT ROTATED 180°

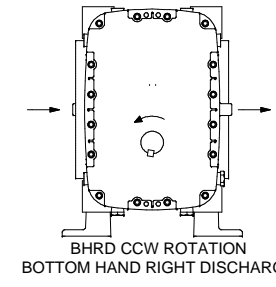
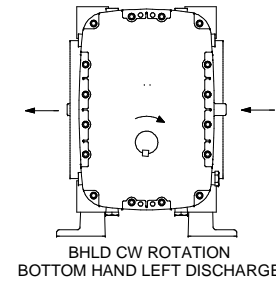
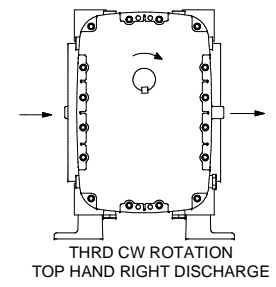
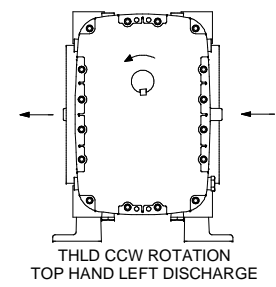

FINISH OF CHAMFERS AND FILLETS TO CONFORM TO ROUNDEST ADJACENT AREA. SURFACE ROUGHNESS MAXIMUM PER ASME B46.1. FULL THREADS THERE ARE MINIMUM.

UNLESS OTHERWISE SPECIFIED DIMENSIONS ARE IN INCHES

TOL. ON DECIMALS: X = ± .05
TOL. ON DECIMALS: XX = ± .02
TOL. ON DECIMALS: XXX = ± .01 AS SPECIFIED
TOL. ON ANGLES: ± 0° 30'

THIRD ANGLE PROJECTION

CONFIDENTIAL - THE INFORMATION CONTAINED IN THIS DOCUMENT IS THE PROPERTY OF GARDNER DENVER, INC. IT IS NOT FOR PUBLIC DISCLOSURE. POSSESSION OF THE INFORMATION DOES NOT CONVEY ANY RIGHT TO LEASE, SELL OR DISCLOSE THE INFORMATION. UNAUTHORIZED REPRODUCTION OR USE OF THE INFORMATION IS PROHIBITED. THIS DOCUMENT IS TO BE RETURNED TO GARDNER DENVER, INC. UPON THE COMPLETION OF THE PURPOSE FOR WHICH IT IS LOANED OR UPON REQUEST.

DIMENSIONING AND TOLERANCING PER ASME Y14.5-2009
THREADS PER ASME B1.1 (GAGING SYSTEM 2) 11.0.2.4, AND B1.20.1 & B1.20.3

Gardner Denver		HEAT TREATMENT	ENG. REF:
Gardner Denver Inc. Quincy, IL		TITLE	OUTLINE-BARE UNIT
DWN BY: 6618 10/7/2011	E	HELIFLOW 514 VERTICAL	
CRD BY: RRB 10/8/2011		303HYE800	

1 of 1

REVISION HISTORY					
ZONE	REV	DESCRIPTION	ECN #	DATE	CHK
	03	CHANGED SIGHT GLASS LOCATION TO RIGHT SIDE	1121287	10-Oct-18	exs7247 mws0121

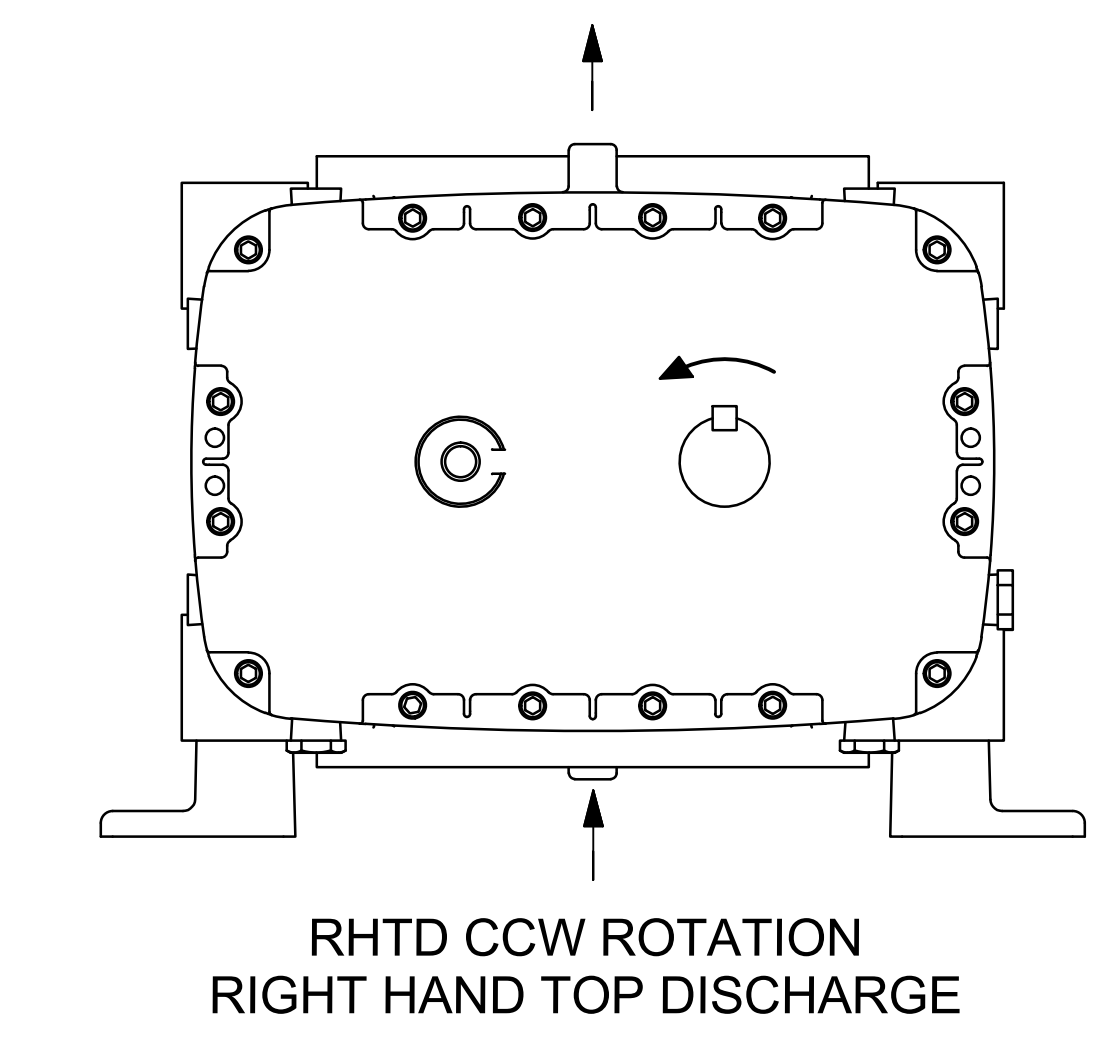
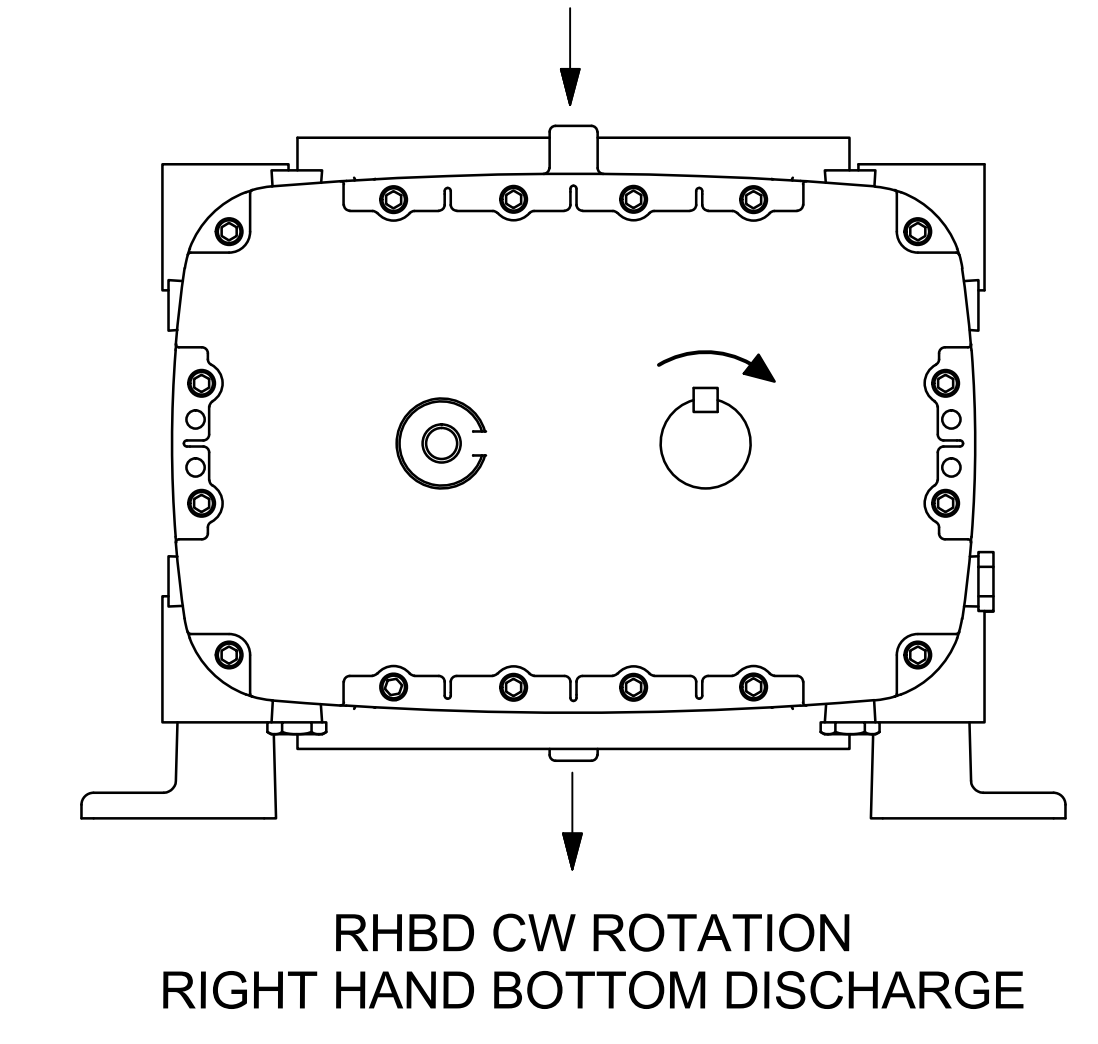
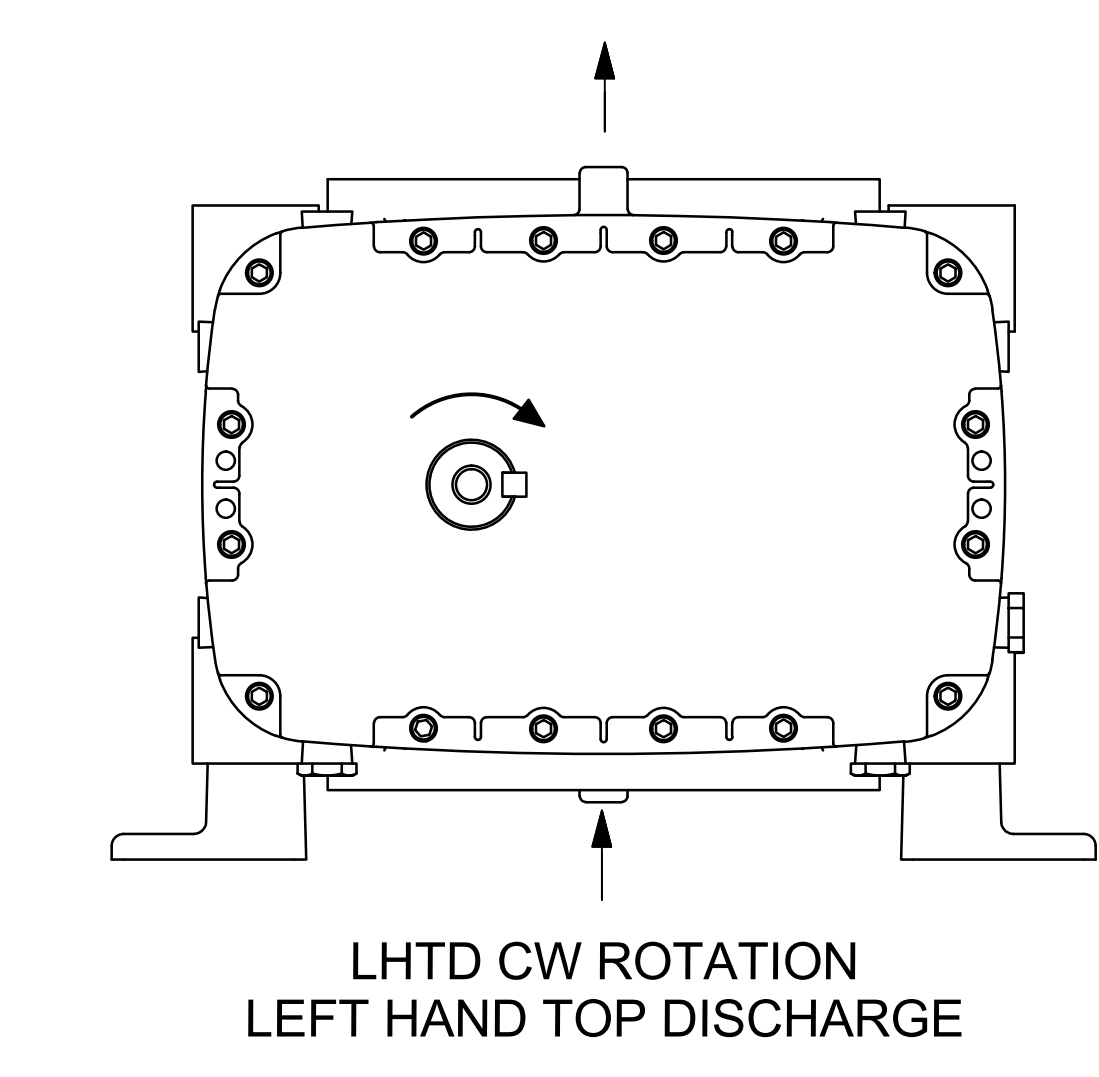
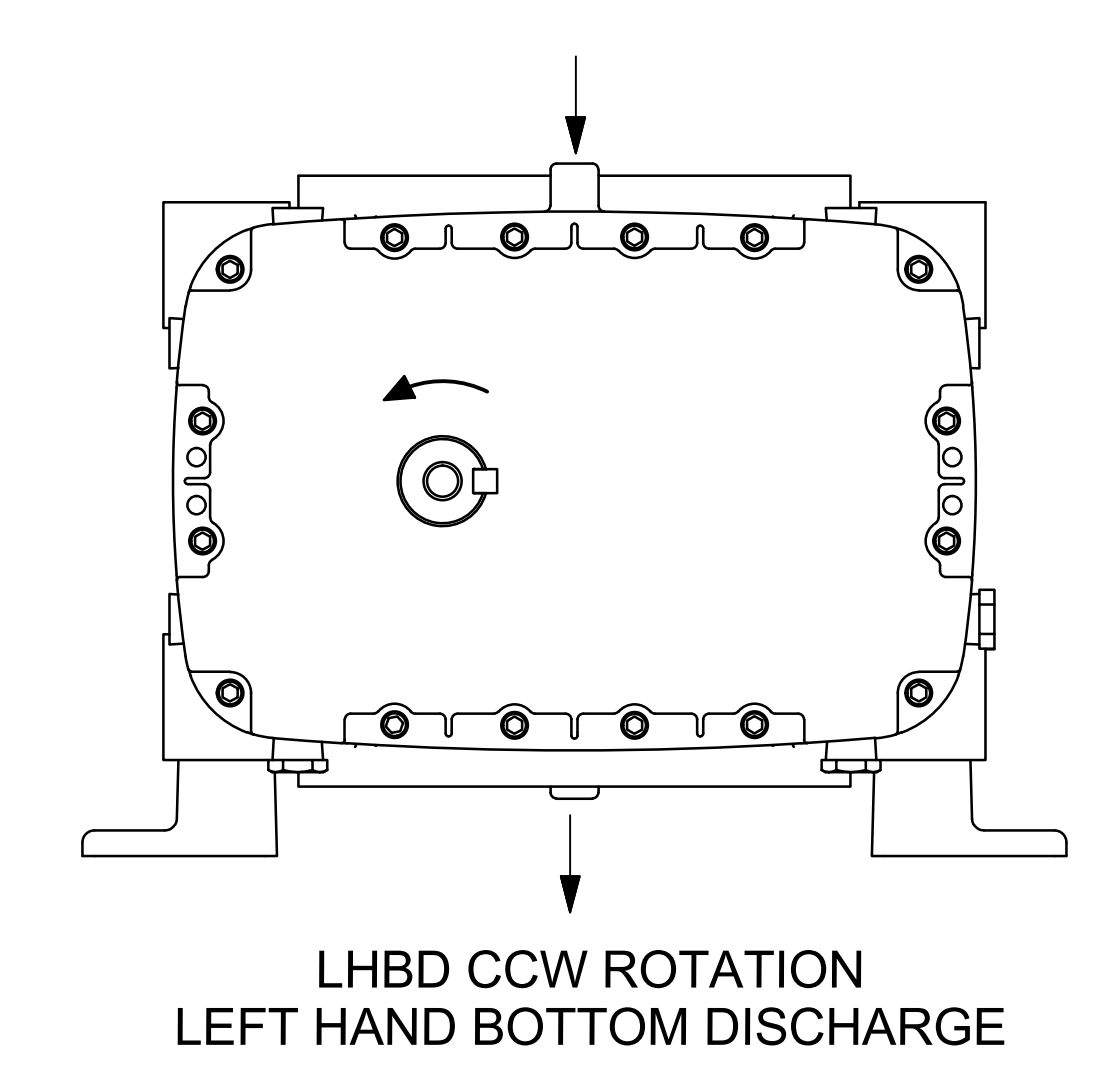
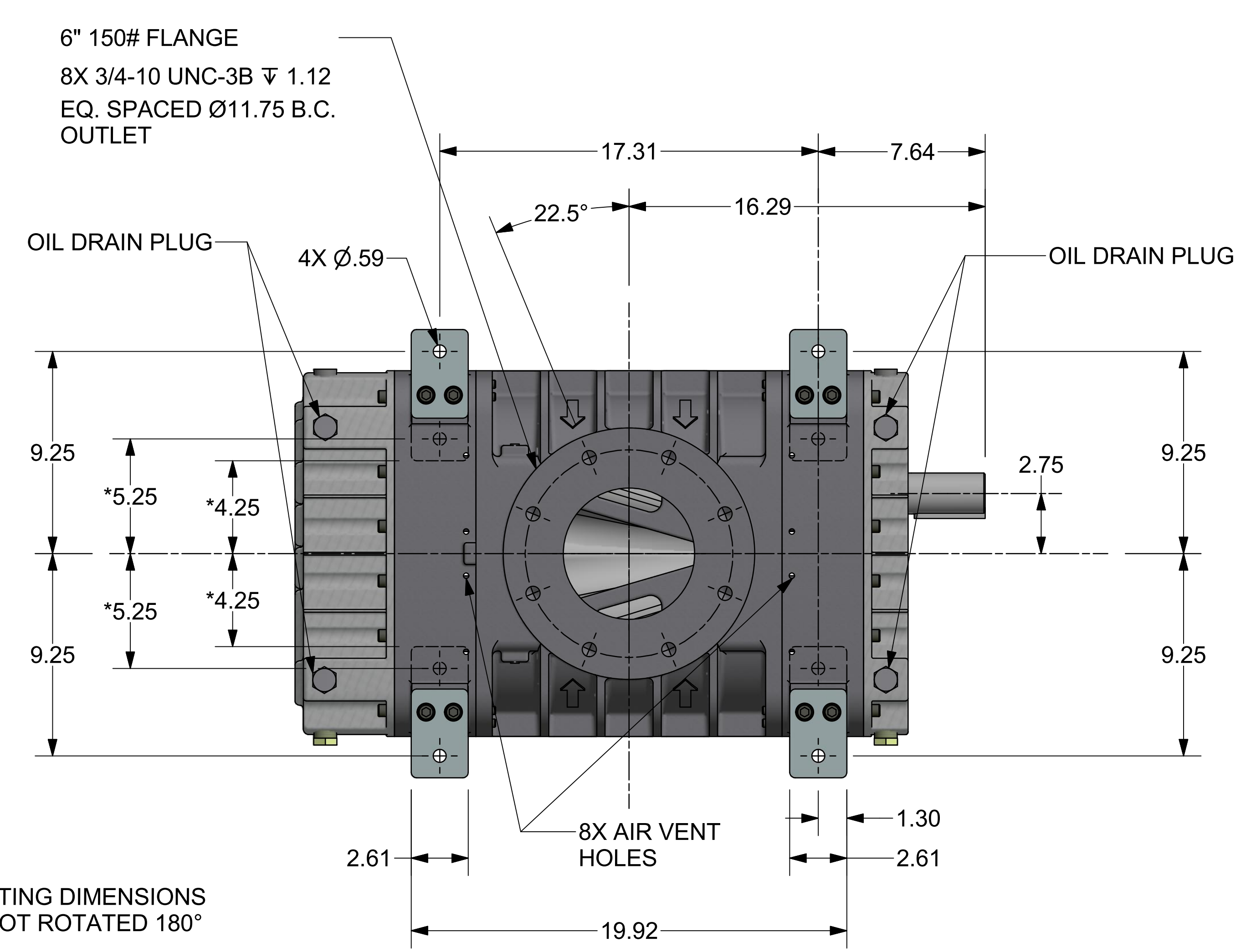
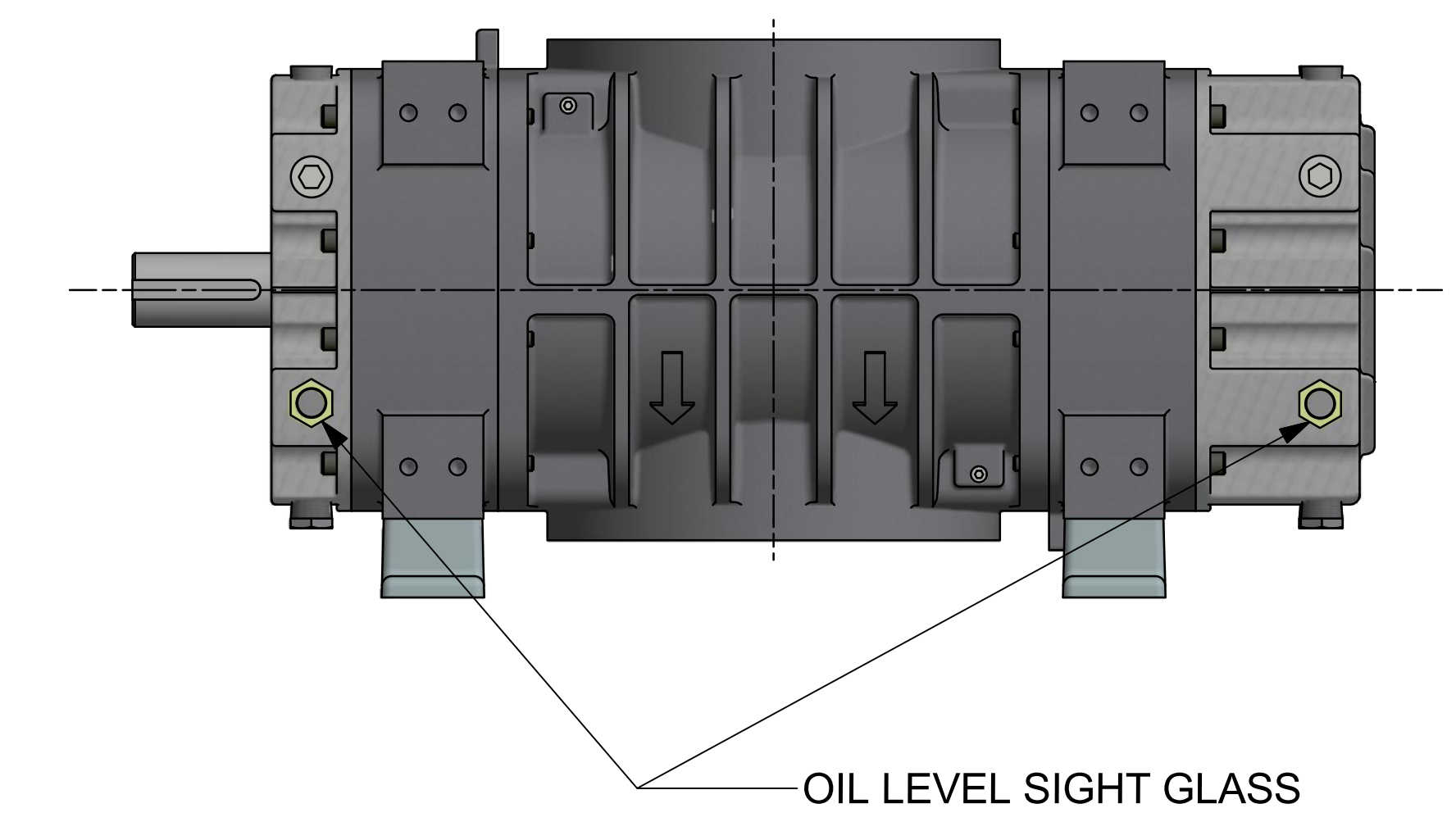
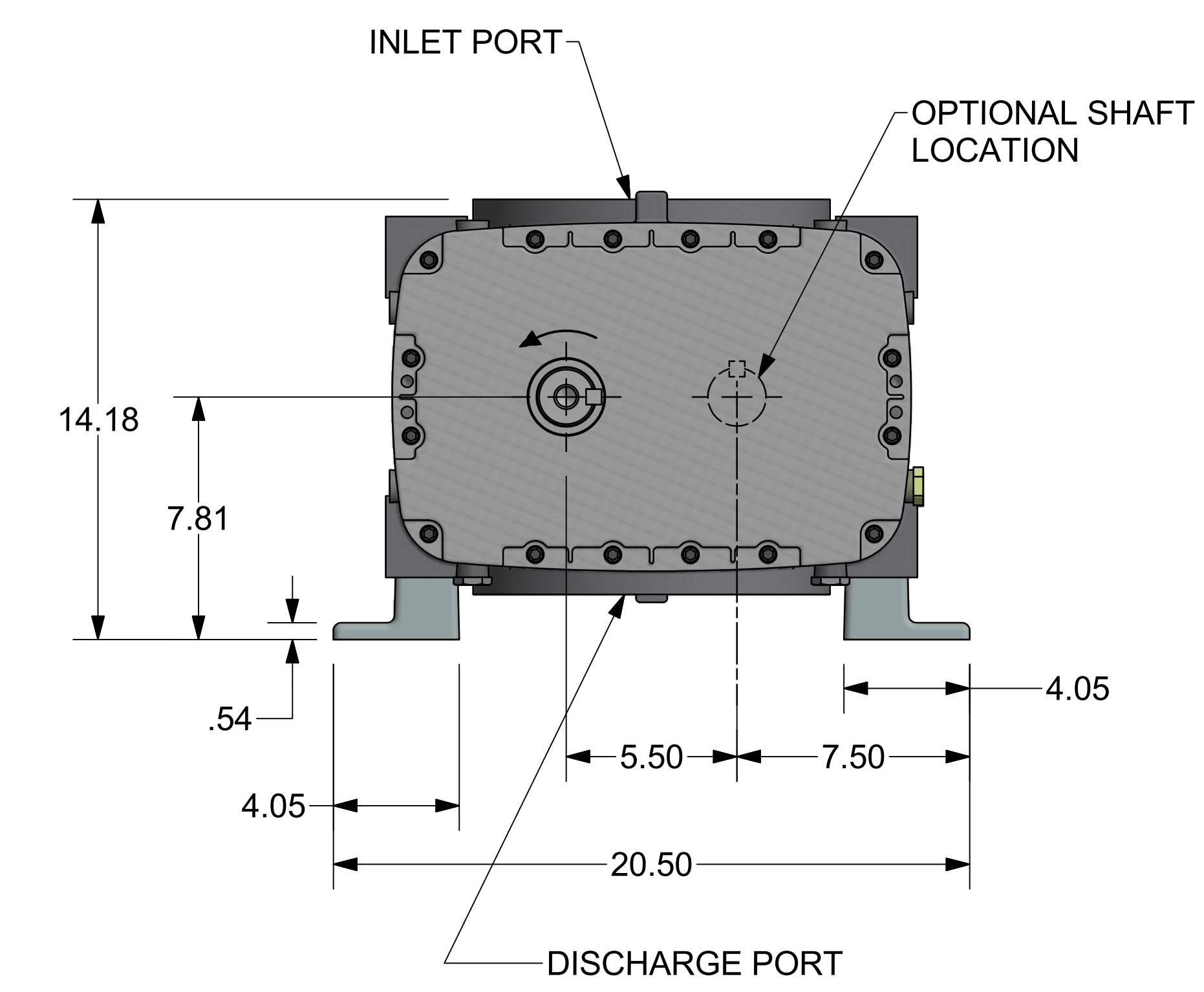
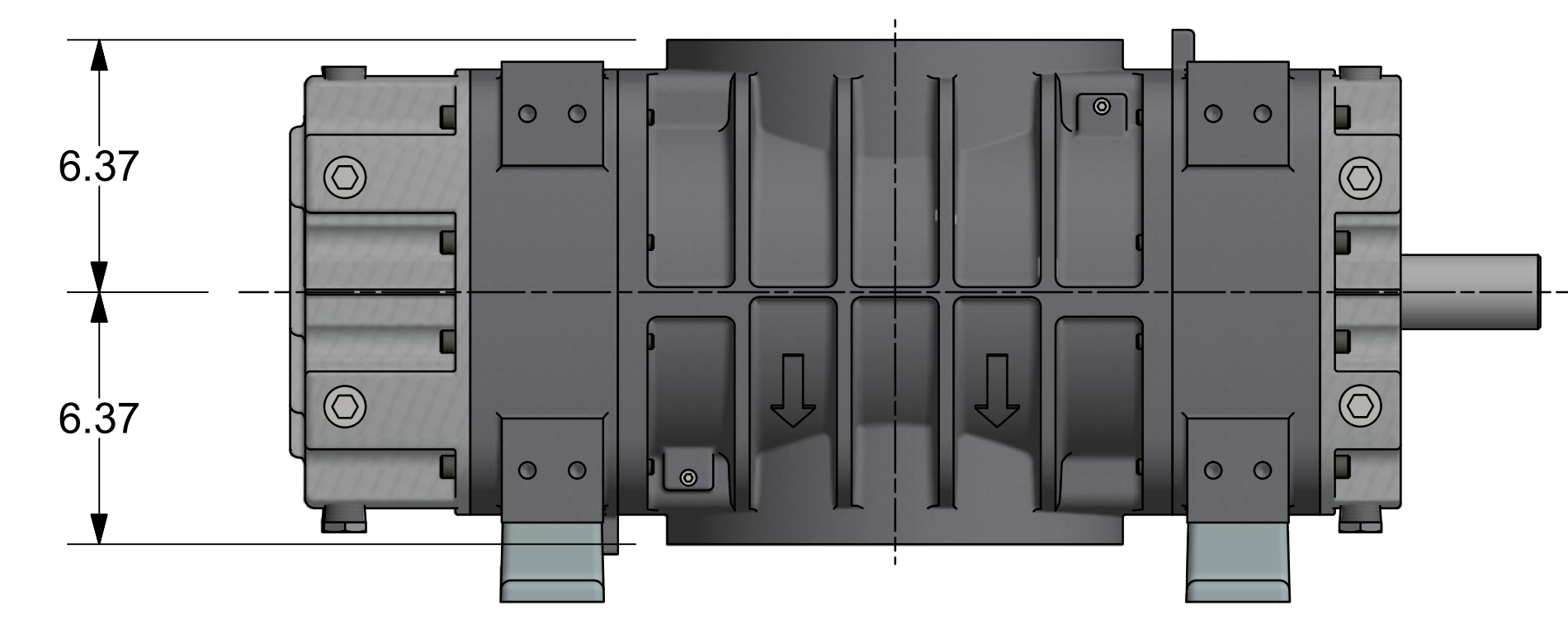
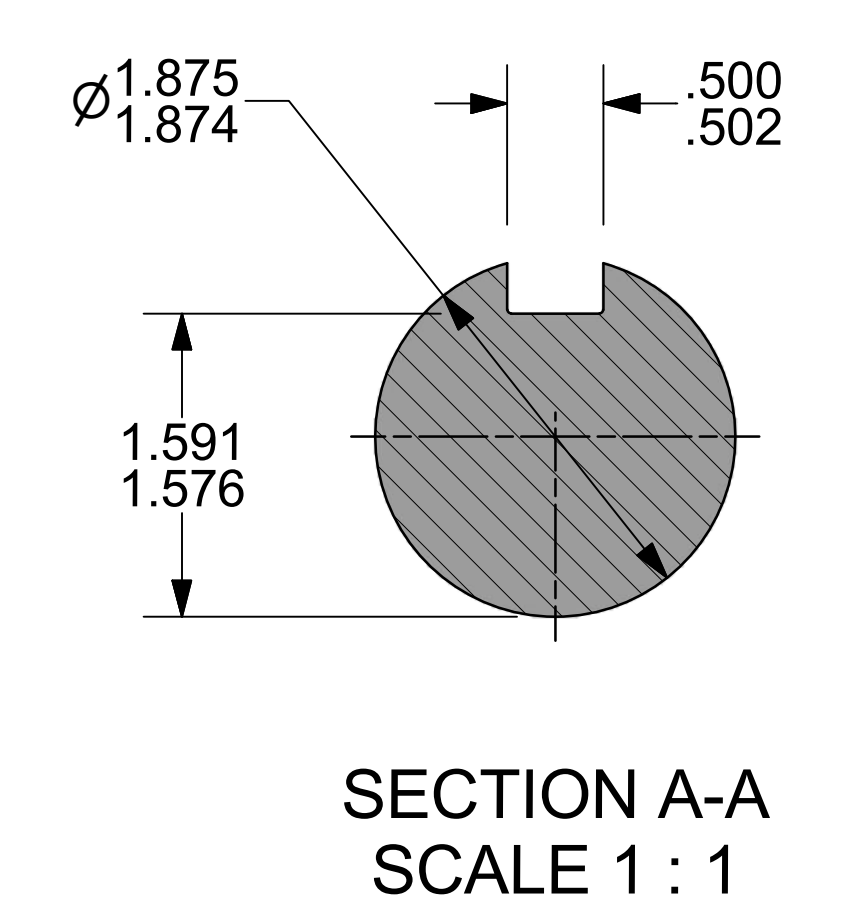
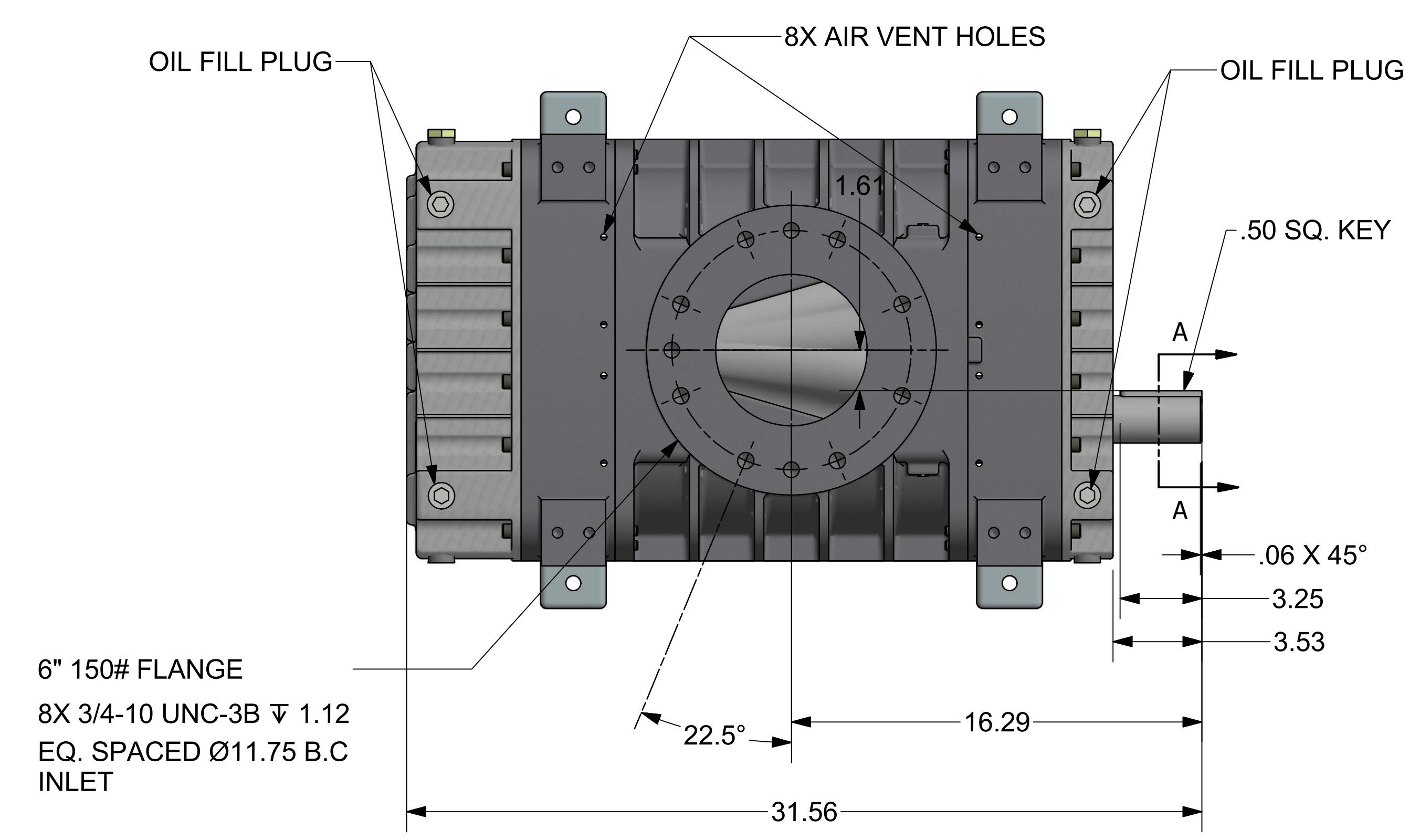

FINISH OF CHAMFERS AND FILLETS TO CONFORM TO ROUGHEST ADJACENT AREA. SURFACE ROUGHNESS MAXIMUM PER ASME B46.1. FULL THREAD DEPTHS ARE MINIMUM.

UNLESS OTHERWISE SPECIFIED DIMENSIONS ARE IN INCHES

TOL. ON DECIMALS: X = \pm .05
TOL. ON DECIMALS: XX = \pm .02
TOL. ON DECIMALS: XXX = \pm AS SPECIFIED
TOL. ON ANGLES: \pm 0'-30"

THIRD ANGLE PROJECTION

CONFIDENTIAL - THE INFORMATION CONTAINED IN THIS DOCUMENT IS THE PROPERTY OF GARDNER DENVER, INC. IT IS NOT FOR PUBLIC DISCLOSURE. POSSESSION OF THE INFORMATION DOES NOT CONVEY ANY RIGHT TO LOAN, SELL, OR DISCLOSE THE INFORMATION. UNAUTHORIZED REPRODUCTION OR USE OF THE INFORMATION IS PROHIBITED. THIS DOCUMENT IS TO BE RETURNED TO GARDNER DENVER, INC. UPON THE COMPLETION OF THE PURPOSE FOR WHICH IT IS LOANED OR UPON REQUEST.

DIMENSIONING AND TOLERANCING PER ASME Y14.5-2009
THREADS PER ASME B1.1 GAGING SYSTEM 21 U.O.S., ANSI B1.20.1 & B1.20.3

HEAT TREATMENT ENG. REF:

Gardner Denver
Gardner Denver Inc.
Quincy, IL

TITLE: **OUTLINE-BARE UNIT**
HELIFLOW 514 HORIZONTAL

DWN BY TAM 09-Oct-11
CKD BY RRB 09-Oct-11

SCALE: 1/4

SHEET 1 OF 1